



Marking Scheme links are on each paper

Pre-Board Sample Papers

CBSE EXAM 2024 30 Sets

Class : 10th

Sub : Science

Disclaimer :

1. These papers are based on the SQP released by CBSE and published by a private organization just for the practice of the students.
2. CBSE has not released these papers and CBSE is not related to these papers in any manner.
3. Publisher of these papers clearly state that these papers are only for practice of students and questions may not be come in main exam.
4. Please do not spread any rumors that any one paper will be coming in main exam.

Sample Paper 1

Class X 2023-24

Science (086)

Time: 3 Hours

Max. Marks: 80

General Instructions:

1. This question paper consists of 39 questions in 5 sections.
2. All questions are compulsory. However, an internal choice is provided in some questions. A student is expected to attempt only one of these questions.
3. Section A consists of 20 Objective Type questions carrying 1 mark each.
4. Section B consists of 6 Very Short questions carrying 02 marks each. Answers to these questions should be in the range of 30 to 50 words.
5. Section C consists of 7 Short Answer type questions carrying 03 marks each. Answers to these questions should be in the range of 50 to 80 words.
6. Section D consists of 3 Long Answer type questions carrying 05 marks each. Answer to these questions should be in the range of 80 to 120 words.
7. Section E consists of 3 source-based/case-based units of assessment of 04 marks each with sub-parts.

SECTION-A

Select and write one most appropriate option out of the four options given for each of the questions 1 – 20.

1. The given figure represents a single nephron from a mammalian kidney. Identify the labelled parts, match them with the options (I-IV) and select the correct answer.
 - (i) The site of Ultrafiltration.
 - (ii) Collect the urine and make it more concentrated.
 - (iii) The main site of reabsorption of glucose and amino acids.
 - (iv) Largely responsible for the maintenance of blood pH.
 - (a) (i)-A, (ii)-B, (iii)-C, (iv)-D
 - (b) (i)-A, (ii)-E, (iii)-C, (iv)-D
 - (c) (i)-E, (ii)-E, (iii)-D, (iv)-A
 - (d) (i)-B, (ii)-A, (iii)-C, (iv)-E

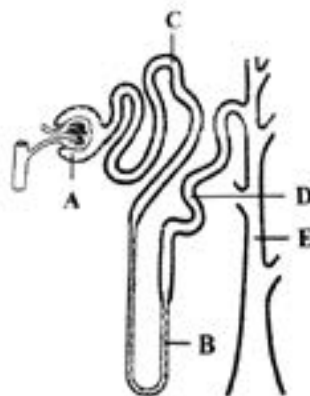

[Click the Button See the free MS/Solutions](#)

SOLUTIONS

2. The table given below shows the reaction of a few elements with acids and bases to evolve Hydrogen gas.

Element	Acid	Base
A.	×	×
B.	✓	✓
C.	✓	×
D.	✓	✓

Which of these elements form amphoteric oxides?

- (a) B and D
(b) A and D
(c) C and D
(d) A and C
3. Quick lime combines vigorously with water to form (A) which reacts slowly with the carbon dioxide in air to form (B). Identify the compounds (A) and (B).

	(A)	(B)
a.	Calcium carbonate	Calcium hydroxide
b.	Calcium hydroxide	Calcium carbonate
c.	Calcium	Calcium bicarbonate
d.	Calcium bicarbonate	Calcium

4. Which among the following is/are double displacement reaction(s)?
- (i) $\text{Pb} + \text{CuCl}_2 \longrightarrow \text{PbCl}_2 + \text{Cu}$
(ii) $\text{Na}_2\text{SO}_4 + \text{BaCl}_2 \longrightarrow \text{BaSO}_4 + 2\text{NaCl}$
(iii) $\text{C} + \text{O}_2 \longrightarrow \text{CO}_2$
(iv) $\text{CH}_4 + 2\text{O}_2 \longrightarrow \text{CO}_2 + 2\text{H}_2\text{O}$
- (a) Only (ii)
(b) (i) and (iv)
(c) (iii) and (iv)
(d) (i) and (ii)
5. What happens when a solution of an acid is mixed with a solution of a base in a test tube?
- (i) The temperature of the solution increases.
(ii) The temperature of the solution decreases.
(iii) The temperature of the solution remains the same.
(iv) Salt formation takes place.
- (a) (i) and (ii)
(b) Only (i)
(c) (i) and (iv)
(d) (ii) and (iii)

Continue on next page.....

6.

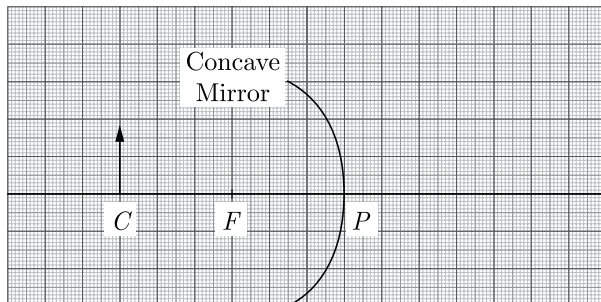

Examine the above figure and state which of the following option is correct? (one small box in the figure is equal to 1 cm).

- The mirror has a focal length of -3 cm and will produce an image of magnification -1.
- The mirror has a focal length of -6 cm and will produce an image of magnification +1.
- The mirror has a focal length of -6 cm and will produce an image of magnification -1.
- The mirror has a focal length of -3 cm and will produce an image of magnification +1.

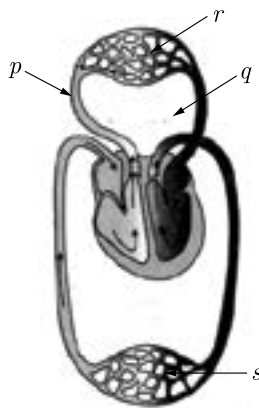
7. Select the correct statement regarding p , q , r and s .

- q represents pulmonary artery that carries oxygenated blood from lungs to heart.
 - p represents pulmonary veins that carries deoxygenated blood from heart to lungs.
 - Exchange of gases takes place in r and oxygenated blood is carried back through aorta.
 - Exchange of gases and substances takes place in s and deoxygenated blood is then carried back to the lungs through vena cava.
8. Two pea plants one with round green seeds ($RRyy$) and another with wrinkled yellow ($rrYY$) seeds produce F_1 progeny that have round, yellow ($RrYy$) seeds. When F_1 plants are selfed, the F_2 progeny will have new combination of characters. Choose the new combination from the following :
- Round, yellow
 - Round, green
 - Wrinkled, yellow
 - Wrinkled, green
- (i) and (iv)
 - (i) and (ii)
 - (i) and (iii)
 - (ii) and (iii)

Continue on next page.....

9. When object is placed at centre of curvature, image is formed at the centre of curvature, i.e. $m = -1$. A student obtains a blurred image of a distant object on a screen using a convex lens. To obtain a distinct image on the screen, he should move the lens:
- towards the screen.
 - away from the screen
 - either towards or away from the screen depending upon the position of the object.
 - to a position very far away from the screen.
10. The molecular formulae of three organic compounds are shown below. Choose the correct option.

Organic Compound	Molecular Compound
<i>P</i>	C_3H_8
<i>Q</i>	C_5H_{10}
<i>R</i>	C_4H_6

Identify the incorrect statement about these three hydrocarbons.

- P*, *Q* both differ by $-CH_2$ unit.
 - ALL have different general formula.
 - Q* is an alkene.
 - P* is an alkane.
11. Which of the following is the correct electronic arrangement of sodium oxide ?

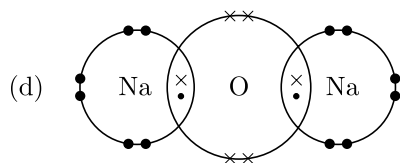
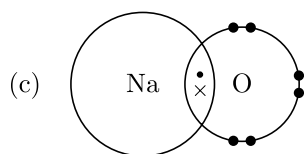
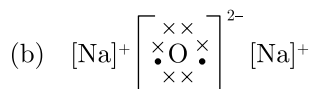
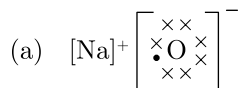

12.

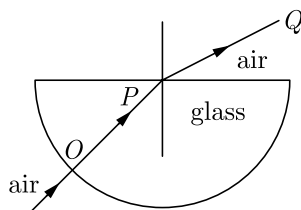

The angle of incidence from air to glass at the point *O* on the hemispherical glass slab is :

- 0°
- 45°
- 180°
- 90°

Click the Button See the free MS/Solutions

SOLUTIONS

13. Which of the following statements are true about the endocrine glands?

- (i) They are ductless glands.
 - (ii) They release their hormones into a duct.
 - (iii) They produce chemical messengers called hormones.
 - (iv) They release their hormones directly into the bloodstream.
- (a) (i), (iii) and (iv) (b) (i) and (iii)
 (c) (i) and (iv) (d) (i), (ii) and (iii)

14. The image shows a bud developing on a Hydra.

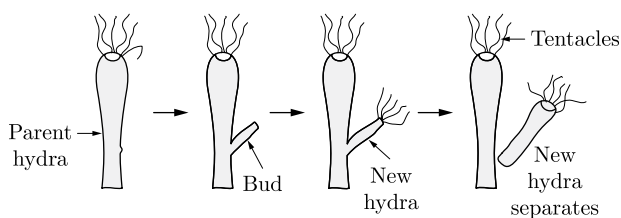

How does the bud develop in the Hydra?

- (a) Bud develops due to repetitive cell division at a specific site
 - (b) Bud develops due to separation of body parts of Hydra
 - (c) Bud develops due to attachment of another Hydra at a specific site
 - (d) Bud develops due to change in the environmental conditions
15. pH of different solutions are given in the table below:

Solution	pH
P	2.2-2.4
Q	13.8-14.0
R	6.5-7.5
S	8.0-9.0

Arrange these solutions in the increasing order of H^+ ion concentration.

- (a) $S < R < Q < P$
 - (b) $P < R < S < Q$
 - (c) $R < S < Q < P$
 - (d) $Q < S < R < P$
16. Different organs of human eye are labelled as A to F.

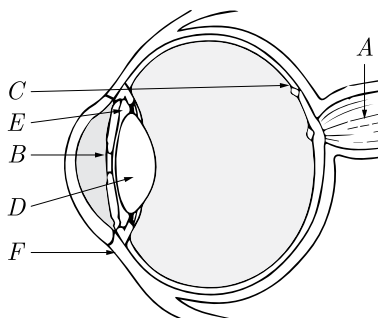

The Structure of Human Eye

Continue on next page.....

When light rays enter the eye, most of the refraction occurs at the:

- (a) part *B*
- (b) part *D*
- (c) part *E*
- (d) outer surface of part *F*

Question no. 17 to 20 are Assertion-Reasoning based questions.

17. **Assertion (A):** The planets twinkle while the stars do not.
Reason (R): The planets are much closer to the earth than the stars.
- (a) Both Assertion (A) and Reason (R) are true and Reason (R) is the correct explanation of Assertion (A).
 - (b) Both Assertion (A) and Reason (R) are true but Reason (R) is not the correct explanation of Assertion (A).
 - (c) Assertion (A) is true but Reason (R) is false.
 - (d) Assertion (A) is false but Reason (R) is true.
18. **Assertion (A):** In human beings, the sex of the individual is largely genetically determined.
Reason (R): In snails, sex is not genetically determined.
- (a) Both Assertion (A) and Reason (R) are true and Reason (R) is the correct explanation of Assertion (A).
 - (b) Both Assertion (A) and Reason (R) are true but Reason (R) is not the correct explanation of Assertion (A).
 - (c) Assertion (A) is true but Reason (R) is false.
 - (d) Assertion (A) is false but Reason (R) is true.
19. **Assertion (A):** Amoeba always produces two daughter amoebae while Plasmodium divides into many daughter cells.
Reason (R): Amoeba undergoes binary fission while Plasmodium undergoes multiple fission.
- (a) Both Assertion (A) and Reason (R) are true and Reason (R) is the correct explanation of Assertion (A).
 - (b) Both Assertion (A) and Reason (R) are true but Reason (R) is not the correct explanation of Assertion (A).
 - (c) Assertion (A) is true but Reason (R) is false.
 - (d) Assertion (A) is false but Reason (R) is true.
20. **Assertion (A):** Burning of natural gas is an endothermic process.
Reason (R): Methane gas combines with oxygen to produce carbon dioxide and water.
- (a) Both Assertion (A) and Reason (R) are true and Reason (R) is the correct explanation of Assertion (A).
 - (b) Both Assertion (A) and Reason (R) are true but Reason (R) is not the correct explanation of Assertion (A).
 - (c) Assertion (A) is true but Reason (R) is false.
 - (d) Assertion (A) is false but Reason (R) is true.

SECTION-B

Question no. 21 to 26 are very short answer questions.

21. (i) List the parts of the human eye that control the amount of light entering into it. Explain how they perform this function.
(ii) Write the function of retina in human eye.

or

Explain using ray diagrams how the defect associated with hypermetropic eye can be corrected.

Click the Button See the free MS/Solutions

SOLUTIONS

22. Give reasons:
- Placenta is extremely essential for foetal development.
 - Uterine lining becomes thick and spongy after fertilisation.
23. Kulhads (disposable cups made of clay) and disposable paper cups both are used as an alternative for disposable plastic cups. Which one of these two can be considered as a better alternative to plastic cups and why?
24. (i) Name the reproductive and non-reproductive parts of bread mould (Rhizopus).
(ii) List any two advantages of vegetative propagation.
25. Observe the given figure and answer the questions that follow:

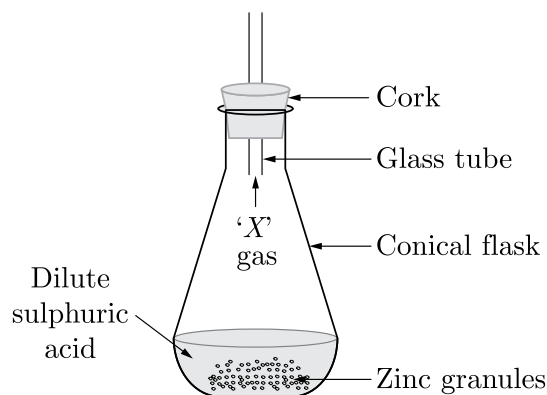

- Identify the gas X .
- Write the chemical reaction involved.
- Which type of chemical reaction is taking place?
- is it an exothermic reaction or an endothermic reaction?

or

What are strong and weak acids? In the following list of acids, separate strong acids from weak acids. Hydrochloric acid, citric acid, acetic acid, nitric acid, formic acid, sulphuric acid.

26. How do auxins promote the growth of a tendril around a support ?

SECTION-C

Question no. 27 to 33 are short answer questions.

27. Differentiate between a glass slab and a glass prism. What happens when a narrow beam of (i) a monochromatic light, and (ii) white light passes through (a) glass slab and (b) glass prism?
28. In the following food chain, only 2J of energy was available to the peacocks. How much energy would have been present in Grass? Justify your answer. Grass → Grass Hopper → Frog → Snake → Peacock.

Continue on next page.....

Click the Button See the free MS/Solutions

SOLUTIONS

29. Two resistors with resistance $10\ \Omega$ and $15\ \Omega$ are to be connected to a battery of emf $12\ \text{V}$ so as to obtain:
- minimum current
 - maximum current

Describe the mode of connecting the resistances in each case. Calculate the strength of the total current in the circuit in each case.

or

- State the relation correlating the electric current flowing in a conductor and the voltage applied across it. Also draw a graph to show this relationship.
 - Find the resistance of a conductor if the electric current flowing through it is $0.35\ \text{A}$ when the potential difference across it is $1.4\ \text{V}$.
30. Analyse the following observation table showing variation of image distance (v) with object distance u in case of a convex lens and answer the questions that follow without doing any calculations:

S.No.	Object distance u (cm)	Image distance v (cm)
1.	-100	+25
2.	-60	+30
3.	-40	+40
4.	-30	+60
5.	-25	+100
6.	-15	+120

- What is the focal length of the convex lens? Give reason to justify your answer.
 - Write the serial number of the observation which is not correct. On what basis have you arrived at this conclusion?
 - Select an appropriate scale and draw a ray diagram for the observation at S.No.2. Also find the approximate value of magnification.
31. During electrolysis of brine, a gas G is liberated at anode. When this gas G is passed through slaked lime, a compound C is formed, which is used for disinfecting drinking water.
- Write formula of G and C .
 - State the chemical equation involved.
 - What is common name of compound C ? Give its chemical name.

32. Nervous and hormonal systems together perform the function of control and coordination in human beings. Justify this statement with the help of an example.

or

List in tabular form three distinguishing features between cerebrum and cerebellum.

33. The general formula of three compounds A , B and C is C_nH_{2n} . B has highest boiling point and C has lowest boiling point.
- Name the homologous series to which A , B and C belongs.
 - Which of these have minimum number of carbon atoms?
 - Write the name and molecular formula of 4th member of this homologous series.

SECTION-D

Question no. 34 to 36 are Long answer questions.

34. (i) Draw a diagram of human excretory system and label on it the following parts:
 (a) Kidney
 (b) Ureter
 (c) Urinary bladder
 (d) Urethra
- (ii) Write one main function each of the labelled parts.
- or**
- (i) Draw a schematic representation of transport and exchange of oxygen and carbon dioxide during transportation of blood in human beings and label on it: Lung capillaries, Pulmonary artery to lungs, Aorta to body, Pulmonary veins from lungs.
- (ii) What is the advantage of separate channels in mammals and birds for oxygenated and deoxygenated blood?
35. State reason for the following statements:
 (i) Tap water conducts electricity whereas distilled water does not.
 (ii) Dry hydrogen chloride gas does not turn blue litmus red whereas dil. HCl does.
 (iii) During summer season, a milkman usually adds a very small amount of baking soda to fresh milk.
 (iv) For dilution of acid, acid is added to water and not water into acid.
 (v) Ammonia is a base but does not contain hydroxyl group.
- or**
- (i) Write the chemical formula of hydrated copper sulphate and anhydrous copper sulphate. Giving an activity illustrate how these are inter-convertible?
 (ii) Write chemical names and formula of plaster of Paris and gypsum.
36. (i) State the rule to determine the direction of a
 (a) magnetic field produced around a straight conductor-carrying current.
 (b) force experienced by a current-carrying straight conductor placed in a magnetic field which is perpendicular to it, and
- (ii) Magnetic field lines of two magnets are shown in fig. (a) and (b).

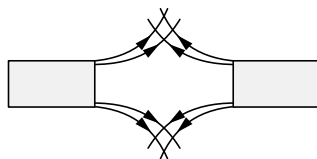

(a)

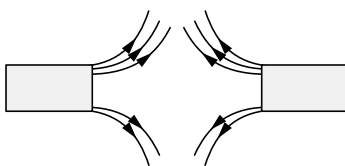

(b)

Select the figure that represent the correct pattern of field lines. Give reason for your answer. Also name the poles of the magnet facing each other.

Click the Button See the free MS/Solutions

SOLUTIONS

SECTION-E

Question no. 37 to 39 are case-based/data-based questions with 2 to 3 short sub-parts. Internal choice is provided in one of these sub-parts.

- 37.** The female reproductive system includes the ovaries, fallopian tubes, uterus, vagina and mammary glands. These organs are involved in the production and transportation of gametes and the production of sex hormones. The female reproductive system also facilitates the fertilisation of ova by sperm and supports the development of offspring during pregnancy and infancy.

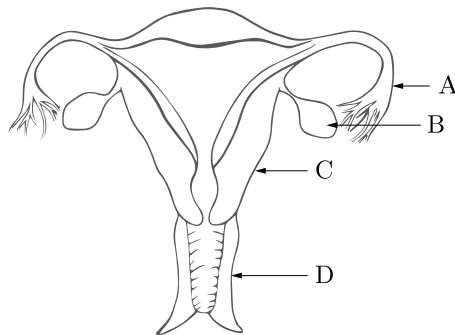

- (i) In which part does:
 (a) fertilisation take place
 (b) foetus develop
- (ii) Which structures in human female are equivalent to the following structures in the male ?
 (a) Testes
 (b) Vas deferenes

In each case say in what respect the structures are equivalent ?

or

- (iii) Write the number of immature eggs present in the ovaries of a newly born baby girl. Mention what happen to these immature eggs when the girl attains puberty ?

- 38.** A student was asked to perform an experiment to study the force on a current carrying conductor in a magnetic field. He took a small aluminium rod AB , a strong horse-shoe magnet, some connecting wires, a battery and a switch and connected them as shown. He observed that on passing current, the rod gets displaced. On reversing the direction of current, the direction of displacement also gets reversed. On the basis of your understanding of this phenomenon, answer the following questions:

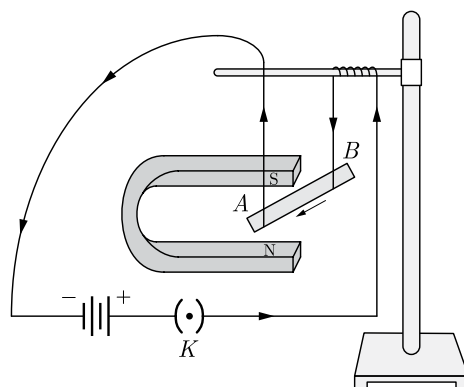

Continue on next page.....

Click the Button See the free MS/Solutions

SOLUTIONS

- (i) Why does the rod get displaced on passing current through it?
- (ii) State the rule that determines the direction of the force on the conductor AB .
- (iii)
- (a) If the U shaped magnet is held vertically and the aluminium rod is suspended horizontally with its end B towards due north, then on passing current through the rod from B to A as shown, in which direction will the rod be displaced?
- (b) Name any two devices that use current carrying conductors and magnetic field.
- or**
- (iv) Draw the pattern of magnetic field lines produced around a current carrying straight conductor held vertically on a horizontal cardboard. Indicate the direction of the field lines as well as the direction of current flowing through the conductor.

39. Ethanol, commonly known as alcohol, is an active ingredient of all alcoholic drinks. It is also used in medicines such as tincture iodine, cough syrups and many tonics. Ethanol's molecular formula is C_2H_6O which means it has two carbon atoms and one oxygen atom. In spite of its many benefits, its impact on social behaviour has been questioned as consumption of even a small quantity of ethanol can cause drunkenness.

- (i) What happens when a small piece of sodium is dropped into ethanol?
- (ii) Name the compound formed when ethanol is warmed with ethanoic acid in the presence of few drops of conc. H_2SO_4 .
- (iii) What is the role of conc. H_2SO_4 in making ethane from ethanol?

or

- (iv) Name two oxidising agents that are used to convert ethanol to ethanoic acids.

□□□□□□

DOWNLOAD INDIA'S BEST STUDY MOBILE APP

- 30 Sample Paper with Solutions
- Chapterwise Question Bank of All Subject
- Previous 15 Years Solved Papers
- NCERT Solutions
- Case Study Questions with full Solutions
- **Word File of Material for Teachers**

Search by **NODIA** on Play Store to Download App

Add 89056 29969 in Your Class Whatsapp Group to Get Link

Click the Button See the free MS/Solutions

SOLUTIONS

Sample Paper 2

Class X 2023-24

Science (086)

Time: 3 Hours

Max. Marks: 80

General Instructions:

1. This question paper consists of 39 questions in 5 sections.
2. All questions are compulsory. However, an internal choice is provided in some questions. A student is expected to attempt only one of these questions.
3. Section A consists of 20 Objective Type questions carrying 1 mark each.
4. Section B consists of 6 Very Short questions carrying 02 marks each. Answers to these questions should be in the range of 30 to 50 words.
5. Section C consists of 7 Short Answer type questions carrying 03 marks each. Answers to these questions should be in the range of 50 to 80 words.
6. Section D consists of 3 Long Answer type questions carrying 05 marks each. Answer to these questions should be in the range of 80 to 120 words.
7. Section E consists of 3 source-based/case-based units of assessment of 04 marks each with sub-parts.

SECTION-A

Select and write one most appropriate option out of the four options given for each of the questions 1 – 20.

1. Calculate the current flowing through the 10Ω resistor in the following circuit.

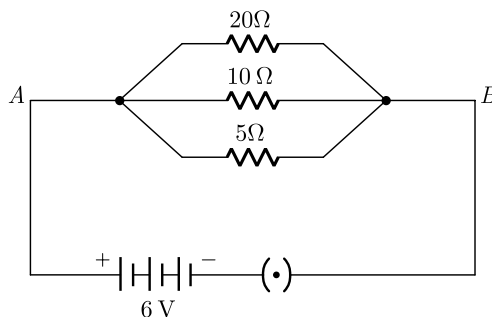

- (a) 0.6 A
(b) 1.2 A
(c) 2.0 A
(d) 0.2 A
2. Three hydrocarbons X, Y and Z are shown below:
X : $\text{CH}_3\text{CH}_2\text{CH}_2\text{CH}_2\text{CH}_3$;
Y : $\text{CH}_3 - \text{C} \equiv \text{C} - \text{CH}_2\text{CH}_3$;
Z : $\text{CH}_3\text{CH}_2 - \text{CH} = \text{CH} - \text{CH}_3$

Identify the incorrect statements about these three hydrocarbons.

- I. X and Y both differ by a $-\text{CH}_2$ unit.
- II. X and Z have the same boiling point.
- III. All have different general formulae.
- IV. Y and Z have different molecular masses.

Continue on next page.....

Click the Following Button to See the Free MS/Solutions

SOLUTIONS

- (a) II and III
- (b) I and II
- (c) All the statements are incorrect.
- (d) I and IV

3. Which of the following phenomena occur, when a small amount of acid is added to water?

- (i) Ionisation
 - (ii) Neutralisation
 - (iii) Dilution
 - (iv) Salt formation
- (a) (i) and (iii)
 - (b) (i) and (ii)
 - (c) (ii) and (iv)
 - (d) (ii) and (iii)

4. Two individuals are as shown using geometric shapes.

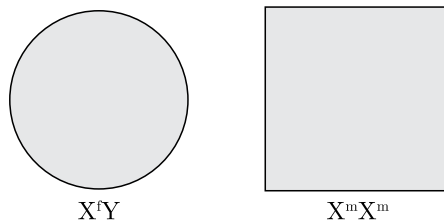

Their sex chromosomes are respectively denoted by $X^f X^m$ and $X^f Y$. What are the possible combinations of sex chromosomes for their male and female offspring respectively?

- (a) $X^m Y$ and $X^m X^m$
- (b) $X^f X^m$ and $X^m X^m$
- (c) $X^m Y$ and $X^m X^f$
- (d) $X^f Y$ and $X^m Y$

5. The directional movement in plants as shown in figure is due to which plant hormone?



- (a) Abscisic acid
- (b) Cytokinins
- (c) Auxin
- (d) Ethylene

6. The image shows the model of a family of dogs.



It can be observed that the offspring is similar to the parent but not identical. What is the likely reason for this?

- (a) Fast multiplication of body cells
 (b) Variation in the genetic material
 (c) Effect of environment on the offspring
 (d) Asexual mode of reproduction
7. Which among the following statements is incorrect for magnesium metal?
- (a) It reacts with cold water to form magnesium oxide and evolves hydrogen gas
 (b) It burns in oxygen with a dazzling white flame
 (c) It reacts with steam to form magnesium hydroxide and evolves hydrogen gas.
 (d) It reacts with hot water to form magnesium hydroxide and evolves hydrogen gas
8. The following reaction is used for the preparation of oxygen gas in the laboratory:

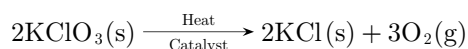

Which of the following statement(s) is(are) correct about the reaction?

- (a) It is a combination reaction.
 (b) It is a decomposition reaction and endothermic in nature.
 (c) It is a photochemical decomposition reaction and exothermic in nature.
 (d) It is a decomposition reaction and accompanied by release of heat.
9. When a 4V battery is connected across an unknown resistor R there is a current of 100 mA in the circuit as shown in the figure. The value of the resistance of the resistor is:

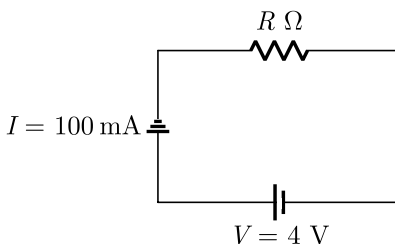

- (a) 40 Ω
 (b) 4 Ω
 (c) 0.4 Ω
 (d) 400 Ω

Click the Following Button to See the Free MS/Solutions

SOLUTIONS

10. In photosynthesis, which substances are used up, which are produced and which are necessary, but remain unchanged after the reaction?

S. No.	Used up	Produced	Remain Unchanged
(a)	Carbon dioxide	Water	Oxygen
(b)	Chlorophyll	Carbon dioxide	Water
(c)	Oxygen	Starch	Cellulose
(d)	Water	Oxygen	Chlorophyll

11. The most suitable material for making the core of an electromagnet is:

- (a) iron
 (b) steel
 (c) aluminium
 (d) soft iron

12. The image shows the Fleming's left-hand rule.

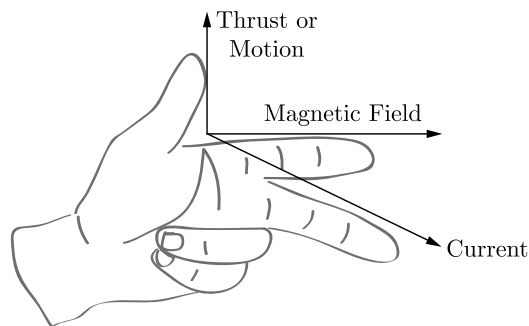

Which option explains the rule to understand the working of motor?

- (a) When a conductor is moved inside a magnetic field, current is produced in the conductor.
 (b) When a current carrying conductor is moved with a force, it creates the magnetic field.
 (c) When a current carrying conductor is placed in a magnetic field, it experiences a force by magnetic field.
 (d) When magnetic field is moved relative to the conductor, current is produced in the conductor.

13. Structural formula of benzene is :

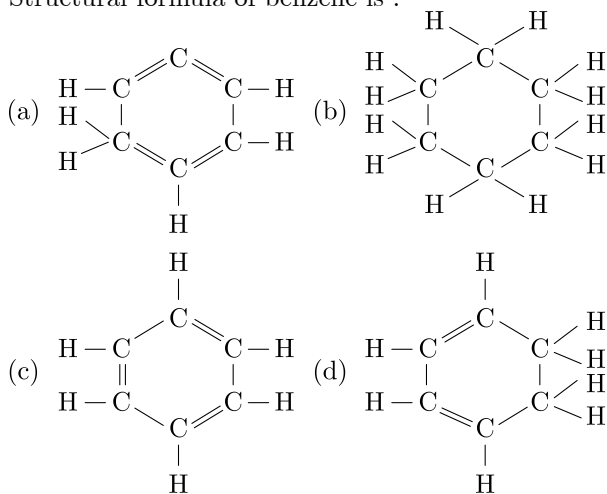

Click the Following Button to See the Free MS/Solutions

SOLUTIONS

14. A student added 10 g of calcium carbonate in a rigid container, secured it tightly and started to heat it. After some time, an increase in pressure was observed, the pressure reading was then noted at intervals of 5min and plotted against time, in a graph as shown below. During which time interval did maximum decomposition took place?

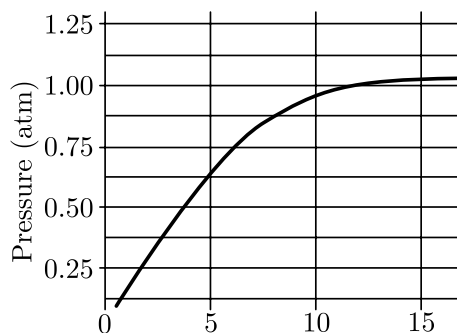

- (a) 10-15 min
(b) 15-20 min
(c) 0-5 min
(d) 5-10 min
15. The diagram given below shows the human excretory system. Identify the function of part labelled as X:

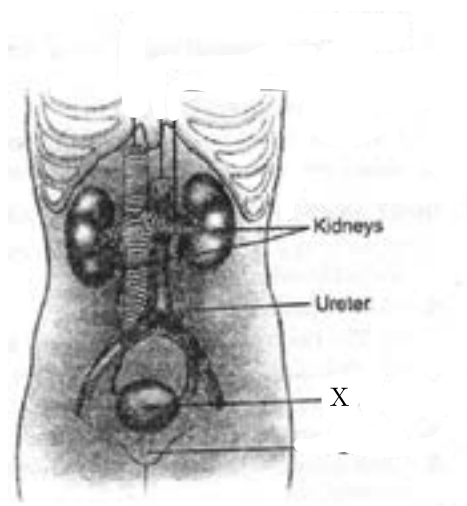

- (a) to produce urea
(b) to excrete urea
(c) to store urine
(d) to produce urine

Continue on next page.....

Click the Following Button to See the Free MS/Solutions

SOLUTIONS

16. In an attempt to demonstrate electrical conductivity through an electrolyte, the following apparatus (Figure) was set up.

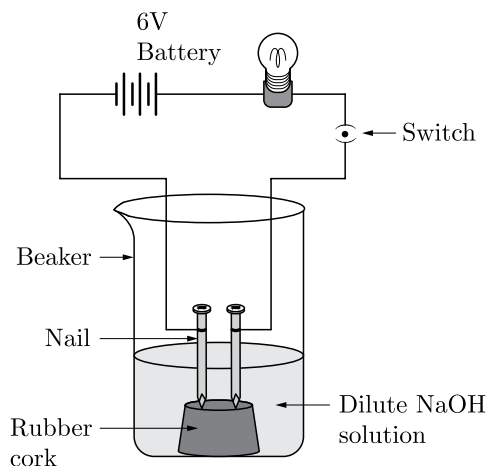

Which among the following statement(s) is (are) correct?

- (i) Bulb will not glow because electrolyte is not acidic.
 - (ii) Bulb will glow because NaOH is a strong base and furnishes ions for conduction.
 - (iii) Bulb will not glow because circuit is incomplete.
 - (iv) Bulb will not glow because it depends upon the type of electrolytic solution.
- (a) (ii) and (iv)
 - (b) (i) and (iii)
 - (c) (iv) only
 - (d) (ii) only

Question no. 17 to 20 are Assertion-Reasoning based questions.

17. **Assertion (A):** Amount and timing of hormones released are regulated by feedback mechanisms.
Reason (R): Hypersecretion or hyposecretion of any hormone has a harmful effect on our body.
- (a) Both Assertion (A) and Reason (R) are true and Reason (R) is the correct explanation of Assertion (A).
 - (b) Both Assertion (A) and Reason (R) are true but Reason (R) is not the correct explanation of Assertion (A).
 - (c) Assertion (A) is true but Reason (R) is false.
 - (d) Assertion (A) is false but Reason (R) is true.
18. **Assertion (A):** Domestic circuits are connected in parallel.
Reason (R): Parallel circuits have same current in every part of the circuit.
- (a) Both Assertion (A) and Reason (R) are true and Reason (R) is the correct explanation of Assertion (A).
 - (b) Both Assertion (A) and Reason (R) are true but Reason (R) is not the correct explanation of Assertion (A).
 - (c) Assertion (A) is true but Reason (R) is false.
 - (d) Assertion (A) is false but Reason (R) is true.
19. **Assertion (A):** Herbivores have longer small intestine than carnivores.
Reason (R): Carnivores can digest cellulose due to the presence of enzyme, cellulase.
- (a) Both Assertion (A) and Reason (R) are true and Reason (R) is the correct explanation of Assertion (A).
 - (b) Both Assertion (A) and Reason (R) are true but Reason (R) is not the correct explanation of Assertion (A).
 - (c) Assertion (A) is true but Reason (R) is false.
 - (d) Assertion (A) is false but Reason (R) is true.

Click the Following Button to See the Free MS/Solutions

SOLUTIONS

20. **Assertion (A):** Clove oil is an olfactory indicator. **Reason (R):** Smell of clove can be characterised in acidic medium, but it cannot be recognised in basic medium.
- Both Assertion (A) and Reason (R) are true and Reason (R) is the correct explanation of Assertion (A).
 - Both Assertion (A) and Reason (R) are true but Reason (R) is not the correct explanation of Assertion (A).
 - Assertion (A) is true but Reason (R) is false.
 - Assertion (A) is false but Reason (R) is true.

SECTION-B

Question no. 21 to 26 are very short answer questions.

21. The diagram given below shows an object O and its image I.

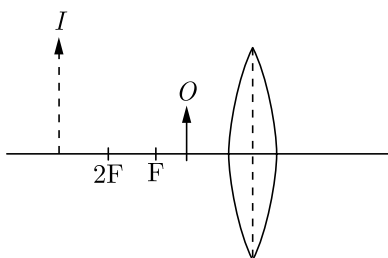

Without actually drawing the ray diagram, state the following :

- Type of lens (Converging/Diverging).
- List three characteristics of the image formed if this lens is replaced by a concave mirror of focal length f and an object is placed at a distance $\frac{f}{2}$ in front of the mirror.

or

Define the following :

- Focal length.
- Principal focus.

22. Look at the following figures. Choose the correct one and give reason for your answer.

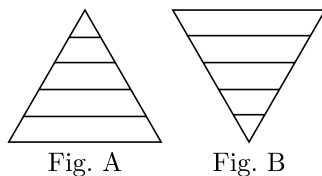

23. Why is the rate of breathing in aquatic organisms much faster than in terrestrial organisms?
24.
 - What is translocation? Why is it essential for plants?
 - Where do the substances in plants reach as a result of translocation?

Continue on next page.....

Click the Following Button to See the Free MS/Solutions

SOLUTIONS

25. Write the names of the following compounds:

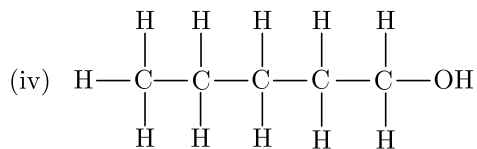
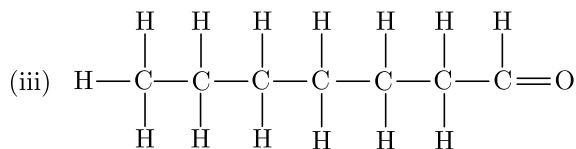
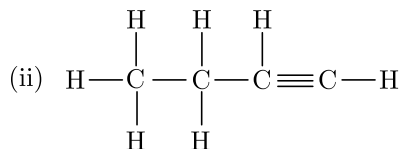
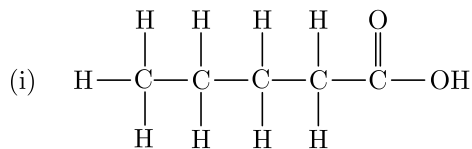

or

A metal that exists as a liquid at room temperature is obtained by heating its sulphide in the presence of air. Identify the metal and its ore and give the reaction involved.

26. Distinguish between unisexual and bisexual flowers giving one example of each.

SECTION-C

Question no. 27 to 33 are short answer questions.

27. (i) Draw a block diagram to show the flow of energy in an ecosystem.
 (ii) In a food chain of frogs, grass, insects and snakes assign trophic level to frogs. To which category of consumers do they belong to?
28. A convex lens made of a material of refractive index n_2 is kept in a medium of refractive index n_1 . A parallel beam of light is incident on the lens. Draw the path of rays of light emerging from the convex lens, if:
- (i) $n_1 < n_2$
 (ii) $n_1 = n_2$
 (iii) $n_1 > n_2$

Continue on next page.....

Click the Following Button to See the Free MS/Solutions

SOLUTIONS

29. (i) List the factors on which the resistance of a conductor in the shape of a wire depends.
 (ii) Why are metals good conductors of electricity whereas glass is a bad conductor of electricity? Give reason.
 (iii) Why are alloys commonly used in electrical heating devices? Give reason.

or

- (i) Write Joule's law of heating.
 (ii) Compute the heat generated while transferring 96000 coulomb of charge in two hours through a potential difference of 40V.
30. A student holding a mirror in his hand, directed the reflecting surface of the mirror towards the Sun. He then directed the reflected light on to a sheet of paper held close to the mirror.
 (i) What should he do to burn the paper?
 (ii) Which type of mirror does he have?
 (iii) Will he be able to determine the approximate value of focal length of this mirror from this activity? Give reason and draw ray diagram to justify your answer in this case.

31. Zinc granules were added to zinc sulphate, copper sulphate, aluminium sulphate and iron sulphate solutions as shown below:

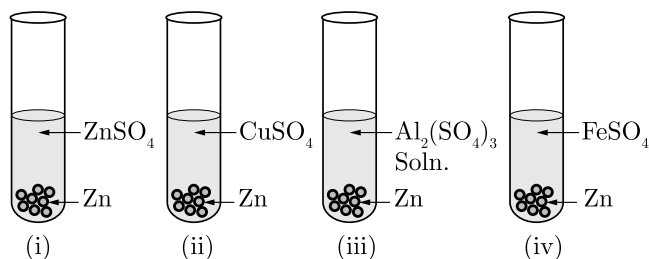

Based on the given information:

- (i) In which test tubes would you observe the deposition of metal on zinc ? Give reason.
 (ii) Arrange Zn, Cu, Al and Fe in the increasing order of reactivity.
32. Complete the following flow chart as per the given instructions :

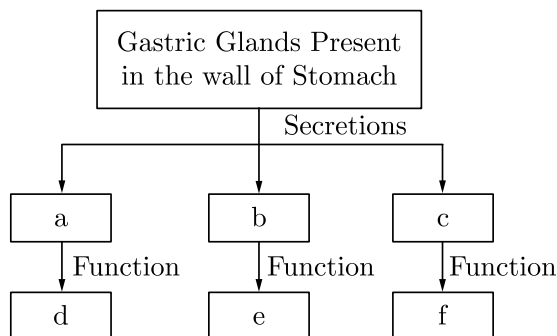

or

Write one function of each of the following components of the transport system in human beings :

- (i) Blood vessels
 (ii) Lymph
 (iii) Heart

Continue on next page.....

Click the Following Button to See the Free MS/Solutions

SOLUTIONS

33. Identify the type of reactions taking place in each of the following cases and write the balanced chemical equation for the reactions.
- Zinc reacts with silver nitrate to produce zinc nitrate and silver.
 - Potassium iodide reacts with lead nitrate to produce potassium nitrate and lead iodide.

SECTION-D

Question no. 34 to 36 are Long answer questions.

34. (i) Draw the diagram of female reproductive system and match and mark the following part(s) :
- Where block is created surgically to prevent fertilisation ?
 - Where Copper-T is inserted ?
 - Inside which condom can be placed ?
- (ii) Why do more and more people prefer to use condoms ? What is the principle behind use of condoms ?

or

Define pollination. Explain the different types of pollination. List two agents of pollination. How does suitable pollination lead to fertilisation ?

35. (i) What is an electromagnet? List any two uses.
- (ii) Draw a labelled diagram to show how an electromagnet is made.
- (iii) State the purpose of soft iron core used in making an electromagnet.
- (iv) List two ways of increasing the strength of an electromagnet, if the material of the electromagnet is fixed
36. (i) Explain the following terms with one example each:
- Corrosion
 - Rancidity
- (ii) Explain two ways by which food industries prevent rancidity.

or

- (i) Balance the following chemical equations:
- $\text{NaOH} + \text{H}_2\text{SO}_4 \longrightarrow \text{Na}_2\text{SO}_4 + \text{H}_2\text{O}$
 - $\text{PbO} + \text{C} \longrightarrow \text{Pb} + \text{CO}_2$
 - $\text{Fe}_2\text{O}_3 + \text{Al} \longrightarrow \text{Al}_2\text{O}_3 + \text{Fe} + \text{Heat}$
- (ii) Write the balanced chemical equations for the following reactions:
- Barium chloride + Potassium sulphate \longrightarrow Barium sulphate + Potassium chloride
 - Zinc + Silver nitrate \longrightarrow Zinc nitrate + Silver

Continue on next page.....

Click the Following Button to See the Free MS/Solutions

SOLUTIONS

SECTION-E

Question no. 37 to 39 are case-based/data-based questions with 2 to 3 short sub-parts. Internal choice is provided in one of these sub-parts.

37. Study the figure related to endocrine glands in human being (male) and answer the questions that follows.

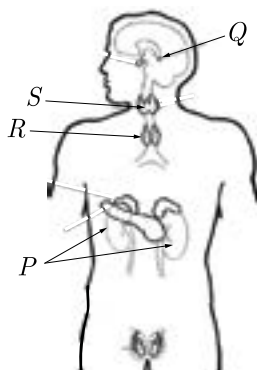

- (i) Which gland secretes digestive enzymes as well as hormones?
- (ii) Which endocrine gland is present in females but not in males?
- (iii) Name the endocrine glands P, Q, R and S.

or

- (iv) Name the hormone responsible for regulation of blood pressure. Also name the gland which secretes this hormone.

38. A girl met with an accident and her leg got fractured. She went to an orthopedician for treatment. On examination, the doctor mixed a white powder in water and applied it to her leg along with the cotton and gauze. After a while, it turned into white, solid, hard mass. The doctor said that it would support her fractured bone and help it to join in the right position.



Continue on next page.....

Click the Following Button to See the Free MS/Solutions

SOLUTIONS

- (i) What is 'white powder' and 'white hard solid mass' called as? Write the chemical name of 'white powder' and 'white hard solid mass'.
- (ii) After treatment, the doctor repacked the white powder back into moisture proof, airtight container. Why ?
- or**
- (iii) Write a chemical equation to show the reaction between white powder and water. Find the difference in water molecules of white hard solid mass and white powder.

39. When light goes from one medium to another medium having different optical densities, then refraction of light rays takes place. All the air in the atmosphere is not at the same temperature. Some of the air layers of the atmosphere are cold (optically denser) whereas other layers of the atmosphere are comparatively warm (optically rarer). So, in the atmosphere we have air layers having different optical densities.

Atmospheric refraction is the deviation of light from a straight line as it passes through the atmosphere due to the variation in air density. Such refraction can raise or lower, or stretch or shorten the images of distant objects and can also make distant objects appear to twinkle or shimmer.

- (i) What is atmospheric refraction?
- (ii) What causes atmospheric refraction?
- (iii) Name the effects produced by atmospheric refraction.
- or**
- (iv) Which has more refractive index-hot air or cold air?

□□□□□□

DOWNLOAD INDIA'S BEST STUDY MOBILE APP

- 30 Sample Paper with Solutions
- Chapterwise Question Bank of All Subject
- Previous 15 Years Solved Papers
- NCERT Solutions
- Case Study Questions with full Solutions
- **Word File of Material for Teachers**

Search by NODIA on Play Store to Download App

Add 89056 29969 in Your Class Whatsapp Group to Get Link

Click the Following Button to See the Free MS/Solutions

SOLUTIONS

Sample Paper 3

Class X 2023-24

Science (086)

Time: 3 Hours

Max. Marks: 80

General Instructions:

1. This question paper consists of 39 questions in 5 sections.
 2. All questions are compulsory. However, an internal choice is provided in some questions. A student is expected to attempt only one of these questions.
 3. Section A consists of 20 Objective Type questions carrying 1 mark each.
 4. Section B consists of 6 Very Short questions carrying 02 marks each. Answers to these questions should be in the range of 30 to 50 words.
 5. Section C consists of 7 Short Answer type questions carrying 03 marks each. Answers to these questions should be in the range of 50 to 80 words.
 6. Section D consists of 3 Long Answer type questions carrying 05 marks each. Answers to these questions should be in the range of 80 to 120 words.
 7. Section E consists of 3 source-based/case-based units of assessment of 04 marks each with sub-parts.
-

SECTION-A

Select and write one most appropriate option out of the four options given for each of the questions 1 – 20.

1. A student determines the focal length of a device X , by focusing the image of a far off object on the screen positioned as shown in figure. The device X is a

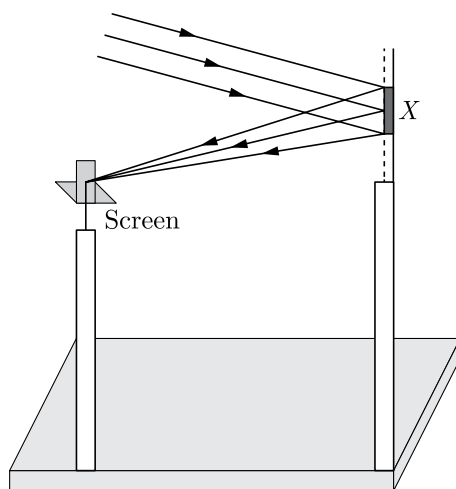

- (a) Convex lens
- (b) Concave lens
- (c) Convex mirror
- (d) Concave mirror

Continue on next page.....

Click the Following Button to See the Free MS/Solutions

SOLUTIONS

2. A student traces the path of a ray of light through a glass prism for different angles of incidence. He analysis each diagram and draws the following conclusion:
- On entering prism, the light ray bends towards its base.
 - Light ray suffers refraction at the point of incidence and point of emergence while passing through the prism.
 - Emergent ray bends at certain angle to the direction of the incident ray.
 - While emerging from the prism, the light ray bends towards the vertex of the prism.
- Out of the above inferences, the correct ones are:
- I, II and III
 - I, III and IV
 - II, III and IV
 - I and IV
3. The reaction that differs from the rest of the reaction given is-
- formation of calcium oxide from limestone
 - formation of aluminium from aluminium oxide
 - formation of sodium carbonate from sodium hydrogen carbonate
 - formation of mercury from mercuric oxide

4. Consider the following table :

Substance	pH
Lemon	2.3
Battery acid	x
Sea water	8.5
Apple	3.1

The value of x in above table is:

- 0
 - 1.3
 - 2.5
 - 1.9
5. Which of the following structures is involved in gaseous exchange in woody stem of a plant as shown in the figure?



- Stomata
- Guard cell
- Lenticel
- Epidermis

Click the Following Button to See the Free MS/Solutions

SOLUTIONS

6. A feature of reproduction that is common to Amoeba, Spirogyra and yeast is that
- they reproduce asexually
 - they are all unicellular
 - they reproduce only sexually
 - they are all multicellular
7. Ethane (C_2H_6) on complete combustion gave CO_2 and water. It shows that the results are in accordance with the law of conservation of mass. Then, the coefficient of oxygen is equal to
- $7/2$
 - $3/2$
 - $5/2$
 - $9/2$
8. When white light passes through the achromatic combination of prisms, then what is observed ?
- Deviation
 - Dispersion
 - Both deviation and dispersion
 - Atmospheric refraction
9. Magnesium reacts with hot water and steam both. Human body stores energy in form of:
- Glucose
 - Insulin
 - glycogen
 - Fructose
10. No matter how far you stand from a mirror, your image appears erect. The mirror is likely to be-
- Plane
 - Concave
 - Convex
 - Either plane or convex
11. What must be preserved in an ecosystem, if the system needs to be maintained?
- producers and carnivores
 - producers and decomposers
 - Carnivores and decomposers
 - Herbivores and carnivores
12. Posture and balance of the body is controlled by
- cerebrum
 - cerebellum
 - medulla
 - pons

Continue on next page.....

Click the Following Button to See the Free MS/Solutions

SOLUTIONS

13. Magnesium ribbon is rubbed with sand paper before making it to burn. The reason of rubbing the ribbon is to:

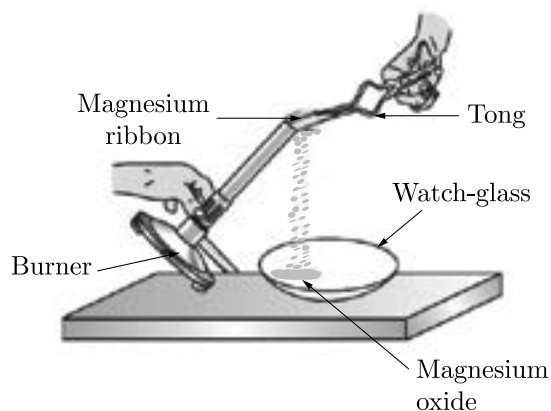

- (a) remove moisture condensed over the surface of ribbon.
(b) generate heat due to exothermic reaction.
(c) remove magnesium oxide formed over the surface of magnesium.
(d) mix silicon from sand paper (silicon dioxide) with magnesium for lowering ignition temperature of the ribbon.
14. Mineral acids are stronger acids than carboxylic acids because
- (i) mineral acids are completely ionized.
(ii) carboxylic acids are completely ionized
(iii) mineral acids are partially ionized
(iv) carboxylic acids are partially ionized
- (a) (i) and (iv)
(b) (ii) and (iii)
(c) (i) and (ii)
(d) (iii) and (iv)
15. Which among the following statements is incorrect for magnesium metal?



- (a) It burns in oxygen with a dazzling white flame.
(b) It reacts with cold water to form magnesium oxide and evolves hydrogen gas.
(c) It reacts with hot water to form magnesium hydroxide and evolves hydrogen gas.
(d) It reacts with steam to form magnesium hydroxide and evolves hydrogen gas.

Continue on next page.....

Click the Following Button to See the Free MS/Solutions

SOLUTIONS

16. Exposure of silver chloride to sunlight for a long duration turns grey due to

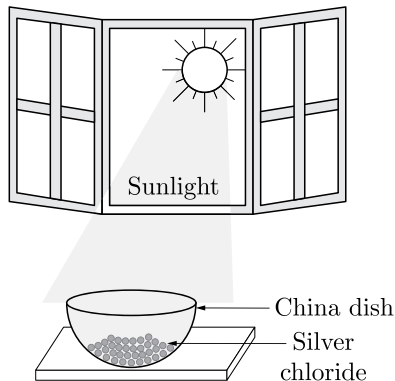

Which among the following statement(s) is(are) true?

1. the formation of silver by decomposition of silver chloride.
 2. sublimation of silver chloride.
 3. decomposition of chlorine gas from silver chloride.
 4. oxidation of silver chloride.
- (a) Only 1
(b) 1 and 3
(c) 2 and 3
(d) Only 4

Question no. 17 to 20 are Assertion-Reasoning based questions.

17. **Assertion :** Photosynthesis is considered as an endothermic reaction.
Reason : Energy gets released in the process of photosynthesis.
- (a) Both Assertion and Reason are True and Reason is the correct explanation of the Assertion.
(b) Both Assertion and Reason are True but Reason is not the Correct explanation of the Assertion.
(c) Assertion is True but the Reason is False.
(d) Both Assertion and Reason are False.
18. **Assertion :** Our body maintains blood sugar level.
Reason : Pancreas secretes insulin which helps to regulate blood sugar levels in the body.
- (a) Both assertion (A) and reason (R) are true and reason (R) is the correct explanation of assertion (A).
(b) Both assertion (A) and reason (R) are true but reason (R) is not the correct explanation of assertion (A).
(c) Assertion (A) is true but reason (R) is false.
(d) Assertion (A) is false but reason (R) is true.
19. **Assertion :** Artificial kidney is a device used to remove nitrogenous waste products from the blood through dialysis.
Reason : Reabsorption does not occur in artificial kidney.
- (a) Both Assertion and Reason are true and Reason is the correct explanation of Assertion.
(b) Both Assertion and Reason are true but Reason is not the correct explanation of Assertion.
(c) Assertion is true but Reason is false.
(d) Assertion is false but Reason is true.

Continue on next page.....

Click the Following Button to See the Free MS/Solutions

SOLUTIONS

20. **Assertion :** The product of resistivity and conductivity of a conductor depends on the material of the conductor.
Reason : Because each of resistivity and conductivity depends on the material of the conductor.
- (a) Both assertion (A) and reason (R) are true and reason (R) is the correct explanation of assertion (A).
(b) Both assertion (A) and reason (R) are true but reason (R) is not the correct explanation of assertion (A).
(c) Assertion (A) is true but reason (R) is false.
(d) Assertion (A) is false but reason (R) is true.

SECTION-B

Question no. 21 to 26 are very short answer questions.

21. What prevents the metals such as magnesium, aluminium, zinc and lead from oxidation at ordinary temperature ?
or
Explain why sodium hydroxide solution cannot be kept in aluminium containers ? Write equation for the reaction that may take for the same.
22. If you keep the potted plant horizontally for 2-3 days, what type of movements would be shown by the shoot and root after two or three days. Why ?
23. What are the rules of inheritance ?
24. What is meant by pollination? Name and differentiate between the two modes of pollination in flowering plants.
25. State two positions in which a concave mirror produces a magnified image of a given object. List two differences between the two images.
or
What is the difference between virtual images produced by concave, plane and convex mirror ?
26. Give two examples each of producers, consumers and decomposer.

SECTION-C

Question no. 27 to 33 are short answer questions.

27. An organic compound with molecular formula C_3H_8O reacts with sodium metal to produce hydrogen gas. Deduce the possible structure of the compound. Write the balanced chemical equation of the reaction.
28. Explain the following chemical changes, giving one example in each case :
(i) Displacement or substitution,
(ii) Dissociation,
(iii) Isomerisation reaction.
29. Our government launches campaigns to provide information about AIDS prevention, testing and treatment by putting posters, conducting radio shows and using other agencies of advertisements.
To which category of diseases AIDS belongs ? Name and explain. What is its causative organism ? Also give two more examples of such diseases.
or
Distinguish between pollination and fertilisation. Mention the site and the product of fertilisation in a flower.

Click the Following Button to See the Free MS/Solutions

SOLUTIONS

30. Why does a ray of light passing through the centre of curvature of a concave mirror after reflection, is reflected back along the same path ?
31. (a) A compound lens is made of two lenses in contact having powers $+12.5\text{ D}$ and -2.5 D . Find the focal length and power of the combination.
 (b) The magnification produced by a mirror is $+1$. What does this mean ?
32. In the given circuit, find :

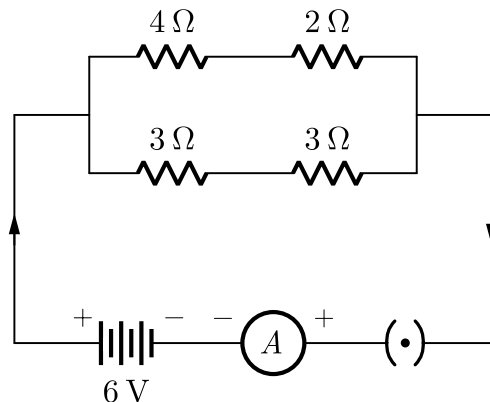

- (a) Total resistance of the network of resistors
 (b) Current through ammeter A

or

The values of current I flowing in a given resistor for the corresponding values of potential difference V across the resistor are given below:

I (ampere)	0.5	1.0	2.0	3.0	4.0
V (volt)	1.6	3.4	6.7	10.2	13.2

Plot a graph between V and I and calculate the resistance of the resistor.

33. (a) How many eggs are produced every month by either of the ovaries in a human female ? Where does fertilization take place in the female reproductive system ?
 (b) What happens in case the eggs released by the ovary are not fertilized?

SECTION-D

Question no. 34 to 36 are Long answer questions.

34. Discuss the physical properties of non-metals.

or

Discuss the exceptions in the properties of metals and non-metals.

Click the Following Button to See the Free MS/Solutions

SOLUTIONS

35. Suggest three contraceptive methods to control the size of human population. Mention two factors that determine the size of population.

or

How do the following organisms reproduce by asexual methods ?

- (a) Euglena
 - (b) Spirogyra
 - (c) Ginger
 - (d) Chrysanthemum
 - (e) Strawberry
 - (f) Mango
36. A household uses the following electric appliances :
- (i) refrigerator of rating 400 W for 10 hours each day.
 - (ii) two electric fans of rating 80 W each for 6 hours daily.
 - (iii) six electric tubes of rating 18 W each for 6 hours daily.
- Calculate the electricity bill for the household for month of June, if cost of electrical energy is ₹ 3.00 per unit.

SECTION-E

Question no. 37 to 39 are case-based/data-based questions with 2 to 3 short sub-parts. Internal choice is provided in one of these sub-parts.

37. Acids, bases and salts are three main categories of chemical compounds. These have certain definite properties which distinguish one class from the other.

The acids are sour in taste while bases are bitter in taste. Tasting a substance is not a good way of finding out if it is an acid or a base! Acids and bases can be better distinguished with the help of indicators. Indicators are substances that undergo a change of colour with a change of acidic, neutral or basic medium. Many of these indicators are derived from natural substances such as extracts from flower petals and barrier. Litmus, a purple dye is extracted from the lichen plant. Some indicators are prepared artificially. For example, methyl orange and phenolphthalein. Given below is a table of indicators and their colour change in acidic and basic medium.

Indicator	Colour in Acid	Colour in Alkali
Litmus	Red	Blue
Methyl	Pinkish red	Yellow
Phenolphthalein	Colourless	Pink

- (i) Give two examples each of natural and artificial indicators.
- (ii) An aqueous solution turns red litmus solution blue. Excess addition of which solution would reverse the change-ammonium hydroxide solution or hydrochloric acid?
- (iii) What will be the change in colour when a few drops of phenolphthalein is added to a solution having pH 8.5.

or

- (iv) What is universal indicator?

Continue on next page.....

Click the Following Button to See the Free MS/Solutions

SOLUTIONS

38. Questions are based on the two table given below. Study these tables related to blood pressure level and answer the question that follow :

Table-A

BLOOD PRESSURE CATEGORY	SYSTOLIC mm Hg (Upper number)	DIASTOLIC mm Hg (Lower number)
Normal	120	80
Elevated	120–129	Less than 80
High Blood Pressure (Hypertension) Stage 1	130–139	80–90
High Blood Pressure (Hypertension) Stage 2	140 or higher	90 or higher
Hypertensive crisis (consult your doctor immediately)	Higher than 180	Higher than 120

Table-B

Time of Measurement	Blood Pressure	
	Patient-X	Patient-Y
Morning	75–115	85–125
Afternoon	79–122	80–120
Evening	82–132	75–110

- (i) In the table B, at which time patient-Y have ideal normal blood pressure ?
(ii) Identify the patient, which have hypertension stage-1 blood pressure ?
(iii) Which Diet is the best for high blood pressure patient ?

or

- (iv) What is the ideal blood pressure measurement of a human ?

39. After coming from playground, Tanu feels very hungry. But still some more time was required by her mother to cook food. While waiting on dining table Tanu was playing with her spoon. All of sudden she observed two different orientations of her face when she looked her face from both sides of spoon. She was confused why the orientation of her face changed in two cases. She was curious to know why her reflected image appears upside down in the one surface of a spoon but the correct way up in the opposite surface.



- (i) Which type of image is formed on the both surface of spoon?
(ii) As tanu move concave surface of spoon towards her face, again she find that there comes a point (provided the spoon is big enough) where her image flips from inverted to upright. State the condition under which it happens ? Is this image real or virtual?

Continue on next page.....

Click the Following Button to See the Free MS/Solutions

SOLUTIONS

- (iii) The given ray diagram depict the correct explanation of the image formed by one surface of the spoon. Name the surface which can form the image as depicted in given ray diagram?

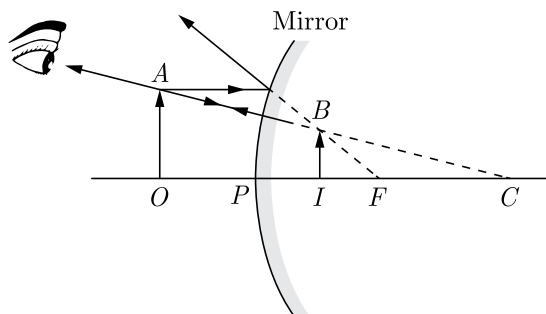

or

- (iv) Tanu was trying to form image using a concave mirror. She got an inverted and real image of same size of the object. Given figure shows four possible positions of the image formed. Figure out the correct position and justify it.

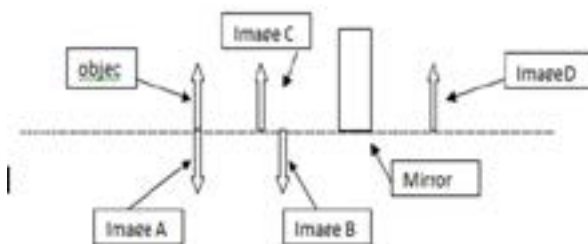

□□□□□□

DOWNLOAD INDIA'S BEST STUDY MOBILE APP

- 30 Sample Paper with Solutions
- Chapterwise Question Bank of All Subject
- Previous 15 Years Solved Papers
- NCERT Solutions
- Case Study Questions with full Solutions
- **Word File of Material for Teachers**

Search by **NODIA** on Play Store to Download App

Add 89056 29969 in Your Class Whatsapp Group to Get Link

Click the Following Button to See the Free MS/Solutions

SOLUTIONS

Sample Paper 4

Class X 2023-24

Science (086)

Time: 3 Hours

Max. Marks: 80

General Instructions:

1. This question paper consists of 39 questions in 5 sections.
 2. All questions are compulsory. However, an internal choice is provided in some questions. A student is expected to attempt only one of these questions.
 3. Section A consists of 20 Objective Type questions carrying 1 mark each.
 4. Section B consists of 6 Very Short questions carrying 02 marks each. Answers to these questions should be in the range of 30 to 50 words.
 5. Section C consists of 7 Short Answer type questions carrying 03 marks each. Answers to these questions should be in the range of 50 to 80 words.
 6. Section D consists of 3 Long Answer type questions carrying 05 marks each. Answer to these questions should be in the range of 80 to 120 words.
 7. Section E consists of 3 source-based/case-based units of assessment of 04 marks each with sub-parts.
-

SECTION-A

Select and write one most appropriate option out of the four options given for each of the questions 1 – 20.

1. The following figures show the path of light rays through three lenses marked L_1 , L_2 and L_3 and their focal points F_1 , F_2 and F_3 respectively.

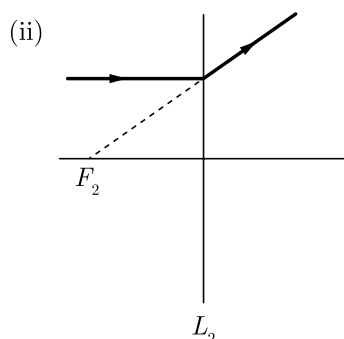
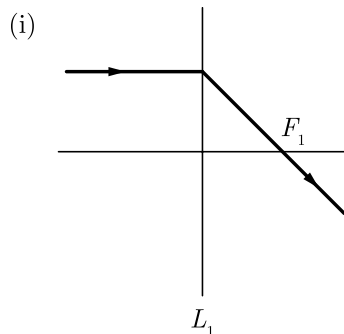

Continue on next page.....

Click the Following Button to See the Free MS/Solutions

SOLUTIONS

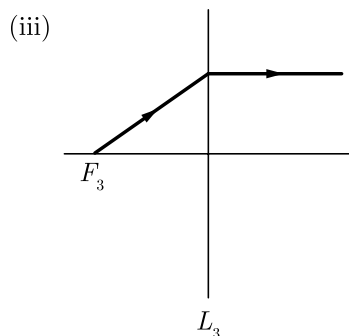

Which of the following diagram shows the concave lens properties?

- (a) (i)
- (b) (ii)
- (c) (iii)
- (d) (i), (ii)

2. Which of the following phenomena contributes significantly to the reddish appearance of sun at sunrise or sunset?



- (a) Dispersion of light
- (b) Scattering of light
- (c) Total internal reflection of light
- (d) Reflection of light from the earth

3. As light travels from a rarer to a denser medium it will have

- (a) increased velocity
- (b) decreased velocity
- (c) decreased wavelength
- (d) both (b) and (c)

4. Refraction of light occurs because of change in velocity or speed of light in different media. When ray of light travels from rarer to denser medium, it moves towards the normal. When it travels from denser to rarer medium, it moves away from the normal. When light ray travels from rarer to denser medium. its velocity and wavelength both decrease. Which of the following statements is/are correct for litmus?

1. Litmus solution is a purple dye.
 2. It is extracted from lichen.
 3. In neutral solution. it remains colourless.
- (a) 1 and 2
 - (b) 2 and 3
 - (c) 1 and 3
 - (d) 1, 2 and 3

Click the Following Button to See the Free MS/Solutions

SOLUTIONS

5. Which of the following are correctly matched?

1.	Bleaching powder	oxidising agent in chemical industries.
2.	Baking powder	a mixture of sodium hydrogen carbonate and a mild edible acid.
3.	Washing soda	remove permanent hardness of water.

- (a) 1 and 2
- (b) 2 and 3
- (c) 1 and 3
- (d) 1, 2 and 3

6.

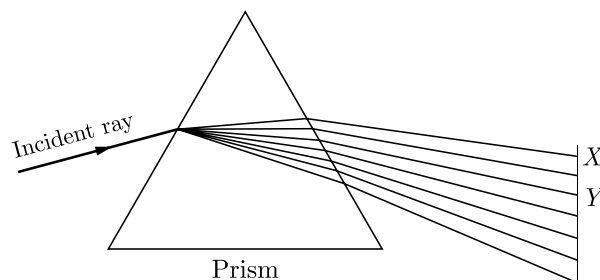

Dispersion of light by glass prism is shown in the above figure. Here x and y indicates and colour respectively.

- (a) red, blue
- (b) red, indigo
- (c) red, yellow
- (d) violet, green

7. Choose the incorrect statement about insulin which is shown in the figure:.



- (a) It is produced from pancreas.
- (b) It regulates growth and development of the body.
- (c) It regulates blood sugar level.
- (d) Insufficient secretion of insulin will cause diabetes.

8. Four chambered heart is characteristics feature of?

- (a) Fishes
- (b) Amphibians
- (c) Reptiles
- (d) Mammals

Click the Following Button to See the Free MS/Solutions

SOLUTIONS

9. The necessary conditions for combustion process to occur are



1. availability of air/oxygen.
 2. availability of air/oxygen and fuel.
 3. temperature of fuel below ignition temperature.
 4. temperature of fuel above ignition temperature.
- Select the correct alternative.
- (a) 1 and 2
 - (b) 2 and 4
 - (c) 3 and 1
 - (d) 4 and 1
10. Translocation is the process in which plants deliver:
- (a) minerals from leaves to other parts of the plant
 - (b) plant growth hormones from leaves to other parts of the plant
 - (c) water and organic substance from leaves to other parts of the plant
 - (d) all of the above
11. Which of the following is not a chemical reaction?
- (a) Souring of milk
 - (b) Dissolution of sugar in water
 - (c) Rusting of iron
 - (d) Digestion of food in the body
12. Which of the following is the correct sequence of events of sexual reproduction in a flower?
- (a) pollination, fertilisation, seedling, embryo
 - (b) seedling, embryo, fertilisation, pollination
 - (c) pollination, fertilisation, embryo, seedling
 - (d) embryo, seedling, pollination, fertilisation.
13. Dissolution of sugar in water is a physical change. Physical changes are changes affecting the form of a chemical substance but not its chemical composition. $\text{Fe}_2\text{O}_3 + 2\text{Al} \rightarrow \text{Al}_2\text{O}_3 + 2\text{Fe}$
- The above reaction is an example of a-
- (a) combination reaction
 - (b) double displacement reaction
 - (c) decomposition reaction
 - (d) displacement reaction

Click the Following Button to See the Free MS/Solutions

SOLUTIONS

14. The ability of metals to be drawn into thin wire is known as



- (a) Ductility
 (b) Malleability
 (c) Sonority
 (d) Conductivity
15. The two versions of a trait (character) which are brought in by the male and female gametes are situated on
 (a) copies of the same chromosome
 (b) two different chromosomes
 (c) sex chromosomes
 (d) any chromosome
16. A soap micelle is shown in the figure. In the soap micelles

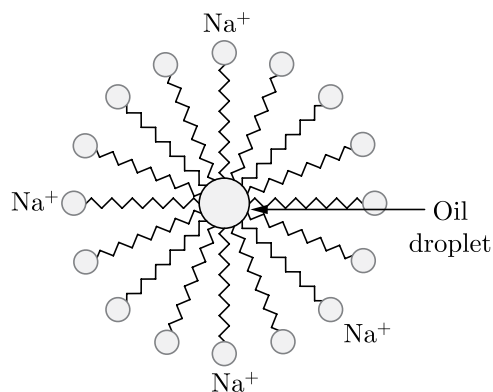

- (a) The ionic end of soap is on the surface of the cluster while the carbon chain is in the interior of the cluster.
 (b) Ionic end of soap is in the interior of the cluster and carbon chain is out of the cluster.
 (c) Both ionic end and carbon chain are in the interior of the cluster.
 (d) Both ionic end and carbon chain are on the exterior of the cluster.

Question no. 17 to 20 are Assertion-Reasoning based questions.

17. **Assertion :** Carbon dioxide turns lime water milky.

Reason : Carbon dioxide sullies the water.

- (a) Both Assertion and Reason are True and Reason is the correct explanation of the Assertion.
 (b) Both Assertion and Reason are True but Reason is not the Correct explanation of the Assertion.
 (c) Assertion is True but the Reason is False.
 (d) Both Assertion and Reason are False.

Click the Following Button to See the Free MS/Solutions

SOLUTIONS

18. **Assertion :** Phototropism is caused by auxin.
Reason : When light is coming from one side of the plant, auxin diffuses towards the shady side of the shoot.
(a) Both assertion (A) and reason (R) are true and reason (R) is the correct explanation of assertion (A).
(b) Both assertion (A) and reason (R) are true but reason (R) is not the correct explanation of assertion (A).
(c) Assertion (A) is true but reason (R) is false.
(d) Assertion (A) is false but reason (R) is true.
19. **Assertion :** Haemoglobin is not the respiratory pigment in human beings.
Reason : It transports oxygen in the human body.
(a) Both Assertion and Reason are true and Reason is the correct explanation of Assertion.
(b) Both Assertion and Reason are true but Reason is not the correct explanation of Assertion.
(c) Assertion is true but Reason is false.
(d) Assertion is false but Reason is true.
20. **Assertion :** A fuse wire is always connected in parallel with the mainline.
Reason : If a current larger than the specified value flows through the circuit, fuse wire melts.
(a) Both Assertion and Reason are true and Reason is correct explanation of the assertion.
(b) Both Assertion and Reason are true but Reason is not the correct explanation of the assertion.
(c) Assertion is true but Reason is false.
(d) Assertion is false but Reason is true.

SECTION-B

Question no. 21 to 26 are very short answer questions.

21. When a metal X is treated with cold water, it gives a base Y with molecular formula XOH (Molecular mass = 40) and liberates a gas Z which easily catches fire. Identify X , Y and Z and also write the reaction involved.
or
What are the constituents of solder alloy ? Which property of solder makes it suitable for welding electrical wires ?
22. On touching a hot plate, you suddenly withdraw your hand. Which category of neurons became active first and which one next ?
23. During crossing why do new features which are not present in the parents appear in the offspring.
24. Are the two cells formed in reproduction are identical?
25. What are the properties of the image formed by a plane mirror ?
or
How do we distinguish a medium to be rarer or denser?
26. What would happen if all the decomposers were eliminated from the earth ? Explain.

SECTION-C

Question no. 27 to 33 are short answer questions.

27. Write the chemical formula and name of the compound which is the active ingredient of all alcoholic drinks. List its two uses. Write chemical equation and name of the product formed when this compound reacts with-
- sodium metal
 - hot concentrated sulphuric acid

Click the Following Button to See the Free MS/Solutions

SOLUTIONS

28. Study the figure given below and answer the following questions :

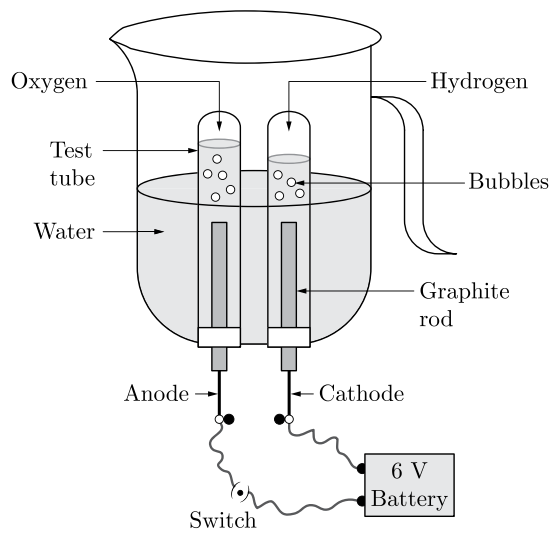

- (a) Name the process depicted in the diagram.
 (b) Write the composition of the anode and the cathode.
 (c) Write the balanced chemical equation of the reaction taking place in this case.
29. (a) What is the role of autosomes ?
 (b) Why is it that offspring receives traits from both the parents.

or

In one of his experiments with pea plants, Mendel observed that when a pure tall pea plant is crossed with a pure dwarf pea plant in the first generation, F_1 only tall plants appear.

- (a) What happens to the traits of the dwarf plants in this case?
 (b) When the F_1 generation plants were self-fertilised, he observed that in the plants of second generation, F_2 both tall plants and dwarf plants were present. Why it happened? Explain briefly.
30. The apparent altitude of stars appears to be generally more than their true altitudes. Explain, how.

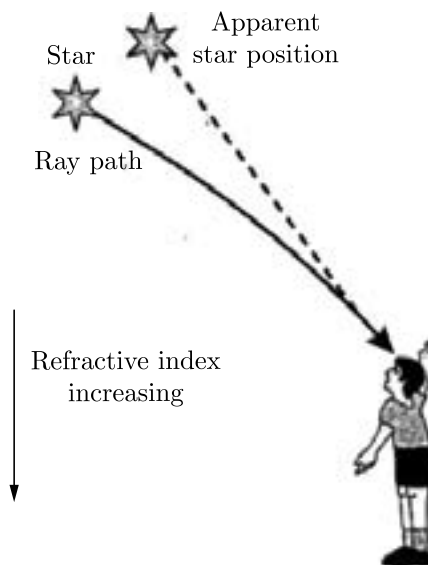

Click the Following Button to See the Free MS/Solutions

SOLUTIONS

31. What are the causes of the following defects of vision and how can they be corrected ?
- Cataract
 - Presbyopia.
32. Calculate the total cost of running the following electrical devices in the month of September, if the rate of 1 unit of electricity is ₹ 6.00.
- Electric heater of 1000 W for 5 hours daily.
 - Electric refrigerator of 400 W for 10 hours daily.

or

- List the factors on which the resistance of a conductor in the shape of wire depends.
 - Why are metals good conductors of electricity whereas glass is a bad conductor of electricity? Give reason.
 - Why are alloys commonly used in electrical heating devices? Give reason.
33. Write one main difference between asexual and sexual mode of reproduction. Which species is likely to have comparatively better chances of survival—the one reproducing asexually or the one reproducing sexually? Give reasons to justify your answer.

SECTION-D

Question no. 34 to 36 are Long answer questions.

34. (a) All ores are minerals but all minerals are not ores. Justify the statement.
 (b) What is galvanisation ?
 (c) Explain roasting with the help of a reaction.
 (d) What do you mean by amalgam ?

or

What are alloys ? How are they made ? Name the constituents and uses of brass, bronze and solder.

35. What is 'phototropism'? How does it occur in plants? Describe an activity to demonstrate phototropism.

or

Name the parts C to G on the diagram of a sensory neuron given here. State two ways in which this neuron differs from a motor neuron.

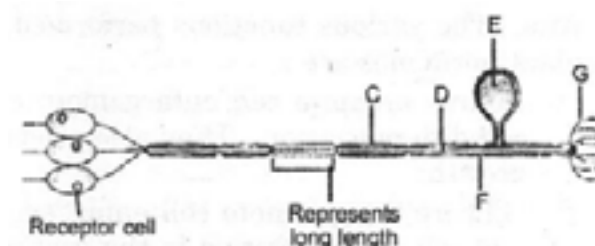

36. (a) Derive the relation for the equivalent resistance when three resistors of resistances R_1 , R_2 and R_3 are connected in parallel.
 (b) Find the minimum resistance that can be made using four resistors, each of $20\ \Omega$.

Click the Following Button to See the Free MS/Solutions

SOLUTIONS

SECTION-E

Question no. 37 to 39 are case-based/data-based questions with 2 to 3 short sub-parts. Internal choice is provided in one of these sub-parts.

37. Oxidation is the process of gaining of oxygen or losing of hydrogen. Reduction is the process of losing of oxygen or gaining of hydrogen. The substance which undergoes oxidation is the reducing agent while the substance which undergoes reduction is known as the oxidising agent. Oxidation and reduction always take place together and these type of reactions are known as redox reactions. Some of the examples of redox reactions are given below :

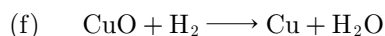
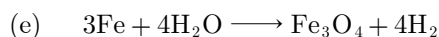
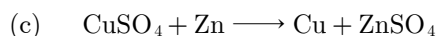
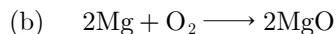

(i) Give two examples of oxidation reaction from your everyday life.

(ii) Write the oxidising agent in the reaction a and b.

or

(iii) Out of oxidation and reduction, which reaction takes place at anode?

38. Answer given questions on the basis of your understanding of the following paragraph and the related studies concepts.

To make a bread dough, a baker mixes flour, sugar and baking powder (mixture of baking soda and tartaric acid). After mixing all the ingredients, the dough is placed in a container for a few hours (in an oven). On heating, the mixture releases carbon dioxide gas leaving bubbles behind. This increases the size of the bread and makes it soft and spongy. Tartaric acid helps in removing bitter taste.

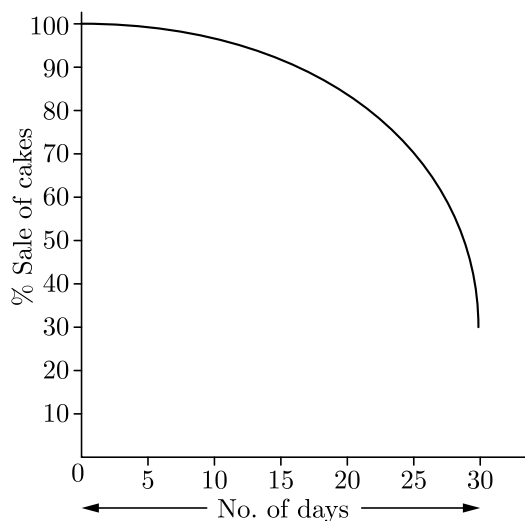

(i) Why does the bread dough rise?

(ii) 'Yeast can be used in place of baking powder for making bread dough'. What is yeast?

(iii) What would you use to measure pH of baking powder?

or

(iv) Based on the graph represented alongside, answer the following questions:

A bakery shop started using baking soda instead of baking powder for baking cakes. What could be the reason for the decrease in the sale of cakes?

Click the Following Button to See the Free MS/Solutions

SOLUTIONS

39. White light is a mixture of seven colours i.e., violet, indigo, blue, green, yellow, orange and red. Every colour has its own characteristic wavelength. Different colours with their wavelengths are given below in the table.

S. No.	Colour	Wavelength
1.	Red	7900 Å
2.	Orange	6000 Å
3.	Yellow	5800 Å
4.	Green	5400 Å
5.	Blue	4800 Å
6.	Indigo	4500 Å
7.	Violet	4000 Å

The phenomenon of splitting white light into seven colours when it passes through a glass prism is called dispersion of white light.

- (i) Name the phenomenon occurring in nature due to dispersion of light.
- (ii) What is monochromatic light?
- (iii) Light of two colours 'A' and 'B' pass through a glass prism. 'A' deviates more than 'B' from its path of incidence. Which colour has a higher speed in the prism ?
- or**
- (iv) On which factor speed of light depends ?

□□□□□□

DOWNLOAD INDIA'S BEST STUDY MOBILE APP

- 30 Sample Paper with Solutions
- Chapterwise Question Bank of All Subject
- Previous 15 Years Solved Papers
- NCERT Solutions
- Case Study Questions with full Solutions
- **Word File of Material for Teachers**

Search by **NODIA** on Play Store to Download App

Add 89056 29969 in Your Class Whatsapp Group to Get Link

Click the Following Button to See the Free MS/Solutions

SOLUTIONS

Sample Paper 5

Class X 2023-24

Science (086)

Time: 3 Hours

Max. Marks: 80

General Instructions:

1. This question paper consists of 39 questions in 5 sections.
 2. All questions are compulsory. However, an internal choice is provided in some questions. A student is expected to attempt only one of these questions.
 3. Section A consists of 20 Objective Type questions carrying 1 mark each.
 4. Section B consists of 6 Very Short questions carrying 02 marks each. Answers to these questions should be in the range of 30 to 50 words.
 5. Section C consists of 7 Short Answer type questions carrying 03 marks each. Answers to these questions should be in the range of 50 to 80 words.
 6. Section D consists of 3 Long Answer type questions carrying 05 marks each. Answer to these questions should be in the range of 80 to 120 words.
 7. Section E consists of 3 source-based/case-based units of assessment of 04 marks each with sub-parts.
-

SECTION-A

Select and write one most appropriate option out of the four options given for each of the questions 1 – 20.

1. Calcium oxide reacts vigorously with water.

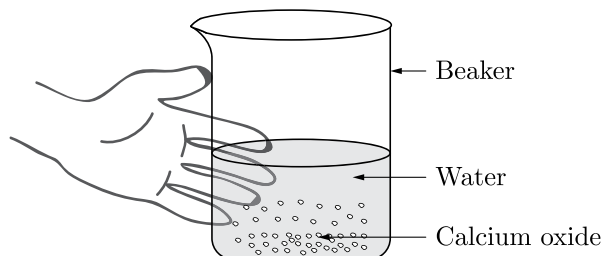

Which of the following is the incorrect observation of the reaction shown in the above set up?

- (a) It is an endothermic reaction.
 - (b) Slaked lime is produced.
 - (c) It is an exothermic reaction.
 - (d) It is a combination reaction.
2. At the time of short circuit, the electric current in the circuit :
- (a) vary continuously
 - (b) does not change
 - (c) reduces substantially
 - (d) increases heavily

Continue on next page.....

Click the Following Button to See the Free MS/Solutions

SOLUTIONS



With the reference of above reaction which one of the option in the table is correct?

	Reactants	Products
(a)	N_2, H_2	NH_3
(b)	NH_3	N_2, H_2
(c)	N_2	H_2, NH_3
(d)	N_2NH_3	H_2

4. A student require hard water for an experiment in his laboratory which is not available in the neighbouring area. In the laboratory there are some salts, which when dissolved in distilled water can convert it into hard water. Select from the following groups of salts, a group, each salt of which when dissolved in distilled water will make it hard.

- Sodium chloride, Potassium chloride
- Sodium sulphate, Potassium sulphate
- Sodium sulphate, Calcium sulphate
- Calcium sulphate, Calcium chloride

5. Structure present in a cell which is responsible for determination of the sex of a baby is :

- cytoplasm
- cell membrane
- nucleus
- chromosome

6. The correct structural formula of butanoic acid is

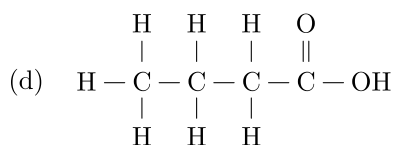
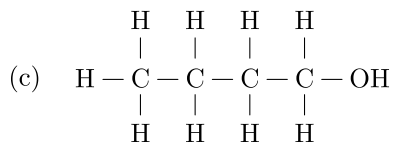
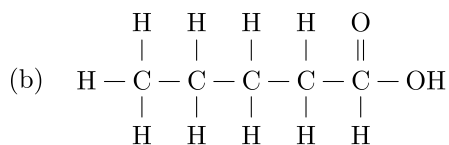
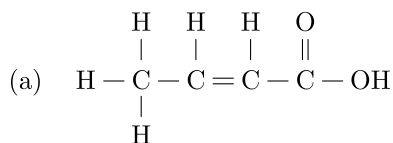

Continue on next page.....

Click the Following Button to See the Free MS/Solutions

SOLUTIONS

7. Which one of the following properties is not general exhibited by ionic compounds?
- Solubility in water
 - Electrical conductivity in solid state
 - High melting and boiling points
 - Electrical conductivity in molten state
8. In an attempt to demonstrate electrical conductivity through an electrolyte, the following apparatus (figure) was set up.

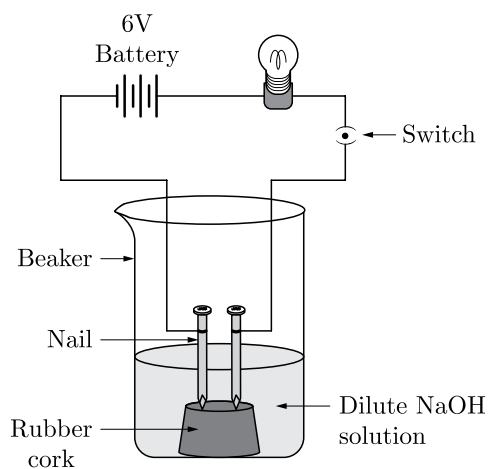

Which among the following statement (s) is (are) correct?

- Bulb will not glow because electrolyte is not acidic.
 - Bulb will glow because NaOH is a strong base and furnishes ions for conduction.
 - Bulb will not glow because circuit is incomplete.
 - Bulb will not glow because it depends upon the type of electrolytic solution.
- 1 and 3
 - 2 and 4
 - Only 2
 - Only 4
9. A student carries out an experiment and plots the V - I graph of three samples of nichrome wire with resistances R_1 , R_2 and R_3 respectively (Figure). Which of the following is true ?

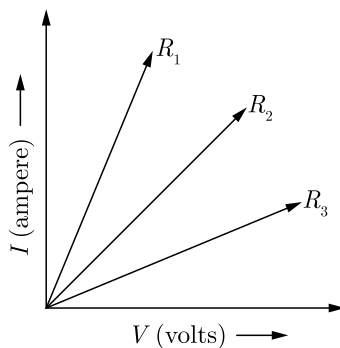

- $R_1 = R_2 = R_3$
- $R_1 > R_2 > R_3$
- $R_3 > R_2 > R_1$
- $R_2 > R_3 > R_1$

Click the Following Button to See the Free MS/Solutions

SOLUTIONS

10. Identify the micro-organism whose nutrition type is shown below :

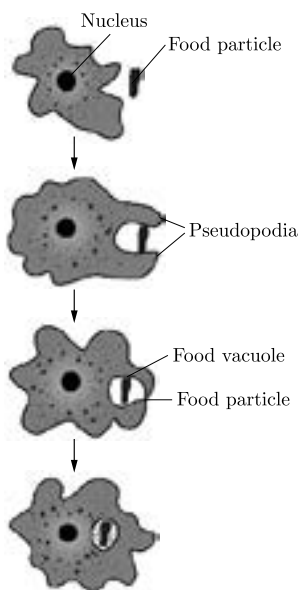

- (a) Food bacteria
- (b) Yeast
- (c) Fungus
- (d) Amoeba

11. In following diagram the parts A, B and C are sequentially

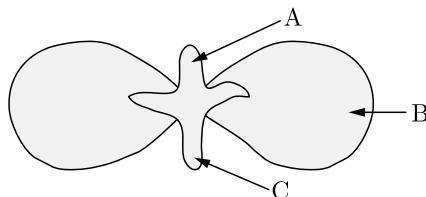

- (a) cotyledon, plumule and radicle
- (b) plumule, radicle and cotyledon
- (c) plumule, cotyledon and radicle
- (d) radicle, cotyledon and plumule

12. If the key in the arrangement taken out (the circuit is made open) and magnetic field lines are drawn over the horizontal plane *ABCD*, the lines are

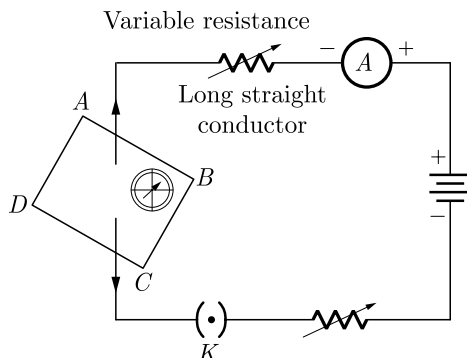

Continue on next page.....

Click the Following Button to See the Free MS/Solutions

SOLUTIONS

- (a) concentric circles
 (b) elliptical in shape
 (c) straight lines parallel to each other
 (d) concentric circles near the point O but of elliptical shapes as we go away from it.
13. Which of the following statement is not correct about the magnetic field?
 (a) Magnetic field lines form a continuous closed curve.
 (b) Magnetic field line do not interest each other.
 (c) Direction of tangent at any point on the magnetic field line curve gives the direction of magnetic field at that point.
 (d) Outside the magnet, magnetic field lines go from South to North pole of the magnet.
14. What is the correct direction of flow of electrical impulses ?

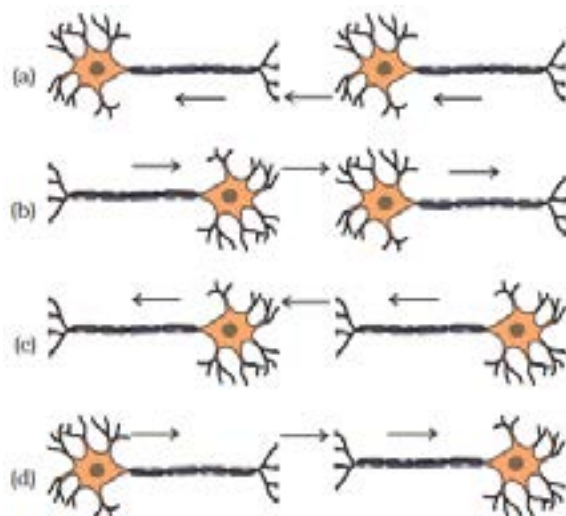

15. Bulb will glow because NaOH is a strong base and furnishes ions for conduction. The diagram shows the arrangement of cells inside the leaf of a green plant. (No cell contents are shown).

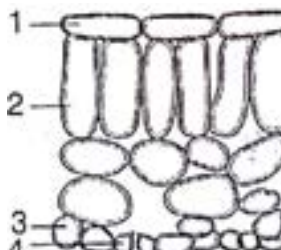

Which of the following cells normally contain chloroplasts?

- (a) 2 and 4
 (b) 2 and 3
 (c) 1 and 2
 (d) 1 and 4

Continue on next page.....

Click the Following Button to See the Free MS/Solutions

SOLUTIONS

16. The following reaction is an example of a
 $4\text{NH}_3(\text{g}) + 5\text{O}_2(\text{g}) \longrightarrow 4\text{NO}(\text{g}) + 4\text{H}_2\text{O}(\text{g})$
1. displacement reaction
 2. combination reaction
 3. redox reaction
 4. neutralisation reaction
- (a) 1 and 4
(b) 2 and 3
(c) 1 and 3
(d) 3 and 4

Question no. 17 to 20 are Assertion-Reasoning based questions.

17. **Assertion :** Corrosion of iron is a serious problem.
Reason : Every year an enormous amount of money is spent to replace damaged iron.
- (a) Both Assertion and Reason are True and Reason is the correct explanation of the Assertion.
(b) Both Assertion and Reason are True but Reason is not the Correct explanation of the Assertion.
(c) Assertion is True but the Reason is False.
(d) Both Assertion and Reason are False.
18. **Assertion :** Dominant allele is an allele whose phenotype expresses even in the presence of another allele of that gene.
Reason : It is represented by a capital letter, e.g. T.
- (a) Both assertion (A) and reason (R) are true and reason (R) is the correct explanation of assertion (A).
(b) Both assertion (A) and reason (R) are true but reason (R) is not the correct explanation of assertion (A).
(c) Assertion (A) is true but reason (R) is false.
(d) Assertion (A) is false but reason (R) is true.
19. **Assertion :** All the plants possess autotrophic mode of nutrition.
Reason : Due to the presence of green coloured pigment chlorophyll in them.
- (a) Both Assertion and Reason are true and Reason is the correct explanation of Assertion.
(b) Both Assertion and Reason are true but Reason is not the correct explanation of Assertion.
(c) Assertion is true but Reason is false.
(d) Both Assertion and Reason are false.
20. **Assertion :** The magnetic field produced by a current carrying solenoid is independent of its length and cross-section area.
Reason : The magnetic field inside the solenoid is uniform.
- (a) Both assertion (A) and reason (R) are true and reason (R) is the correct explanation of assertion (A).
(b) Both assertion (A) and reason (R) are true but reason (R) is not the correct explanation of assertion (A).
(c) Assertion (A) is true but reason (R) is false.
(d) Assertion (A) is false but reason (R) is true.

Continue on next page.....

Click the Following Button to See the Free MS/Solutions

SOLUTIONS

SECTION-B

Question no. 21 to 26 are very short answer questions.

21. A metal is treated with dil H_2SO_4 , the gas evolved is collected by the method shown in the figure. Answer the following :
- Name the gas.
 - Name the method of collection of the gas.

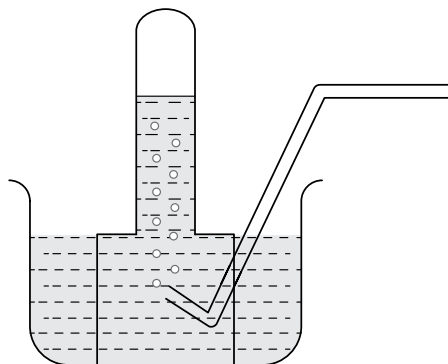

or

List any two observations when a highly reactive metal is dropped in water.

22. What do you mean by diffusion ?
23. Which are the first simple molecules of food produced during photosynthesis ? What happens to these simple molecules in the leaves later ?
24. What is the meaning of the term “assimilation” ?
25. Draw a neat diagram to show the refraction of a light ray through a glass prism and label on it the angle of incidence and angle of deviation.

or

What is the scattering of light ? Explain with the help of an example.

26. What will happen to the garbage and dead animals and plants in absence of microorganisms ?

SECTION-C

Question no. 27 to 33 are short answer questions.

27. State which of the following chemical reactions will take place or not, giving suitable reason for each :
- $\text{Zn(s)} + \text{CuSO}_4(\text{aq}) \rightarrow \text{ZnSO}_4(\text{aq}) + \text{Cu(s)}$
 - $\text{Fe(s)} + \text{ZnSO}_4(\text{aq}) \rightarrow \text{FeSO}_4(\text{aq}) + \text{Zn(s)}$
 - $\text{Zn(s)} + \text{FeSO}_4(\text{aq}) \rightarrow \text{ZnSO}_4(\text{aq}) + \text{Fe(s)}$

Continue on next page.....

Click the Following Button to See the Free MS/Solutions

SOLUTIONS

28. Give reasons for the following :
- Shining surfaces of metals become dull on exposure to air and moisture.
 - Aluminium is extracted from its ore by electrolysis of molten ore.
 - Gold is available in the native state.
29. Mention the three kinds of cells present in blood. Write one function of each.
- or**
- With the help of diagram explain how exchange of gases occurs in leaf of a plant.
30. Manju is uses a concave mirror for image formation for different positions of an object. What inferences can be drawn about the following when an object is placed at a distance of 10 cm from the pole of a concave mirror of focal length 15 cm ?
- Position of the image
 - Size of the image
 - Nature of the image
- Draw a labelled ray diagram to justify your inferences.
31. (a) Define optical centre of a spherical lens.
(b) You are given a convex lens of focal length 30 cm. Where would you place an object to get a real, inverted and highly enlarged image of the object ? Draw a ray diagram showing the image formation.
(c) A concave lens has a focal length of 20 cm. At what distance should an object be placed so that it forms an image at 15 cm away from the lens ?
32. Pawan is connected a galvanometer with a coil of insulated copper wire .What would happen if a bar magnet is :
- Pushed into the coil ?
 - Withdrawn from inside the coil ?
 - Held stationary inside the coil ?
- or**
- You are given two identical looking iron bars. Just using these two bars how will you identify whether any or both of these bars is/are a magnet ?
33. Explain the phenomenon of Biological Magnification. How does it affect organisms belonging to different trophic levels particularly the tertiary consumers ?

SECTION-D

Question no. 34 to 36 are Long answer questions.

34. An organic compound *A* is widely used as a preservative in pickles and has a molecular formula $C_2H_4O_2$. This compound reacts with ethanol to form a sweet smelling compound *B*.
- Identify the compound *A*.
 - Write the chemical equation for the reaction with ethanol to form compound *B*.
 - How can we get compound *A* from *B*?
 - Name the process and write corresponding chemical equation.
 - Which gas is produced when compound *A* reacts with washing soda ? Write the chemical equation.
- or**
- The formula of an ester is $CH_3COOC_2H_5$. Write the structural formulae of the corresponding alcohol and the acid.
 - Mention the experimental conditions involved in obtaining ethene from ethanol.
 - Write the chemical equation for the above reaction.

Continue on next page.....

Click the Following Button to See the Free MS/Solutions

SOLUTIONS

35. (a) Write the function of following parts in human female reproductive system :
- Ovary
 - Oviduct
 - Uterus
- (b) Describe in brief the structure and function of placenta.

or

Define the terms :

- Syngamy
 - Triple fusion
 - Implantation
 - Placenta
 - Gestation.
36. The mobile phone is an excellent communication device. Mobile phones uses electromagnetic radiation in the microwave range. Part of the radio wave emitted by the mobile phone handset will be absorbed by the head. Head is in the 'near field' of radiation, so that most of the heating effect occurs in the head. Temperature in the internal ear, brain increases by 1 degree or more. This adversely affect the functioning of these organs since these have fluid filled cavities. But prolonged heating effect can alter brain functions and hearing ability also. Other harmful effects such as Premature Cataract, Confusion and loss of memory may also be possible. Following figure shows that how mobile phone radiation penetrates the brain.

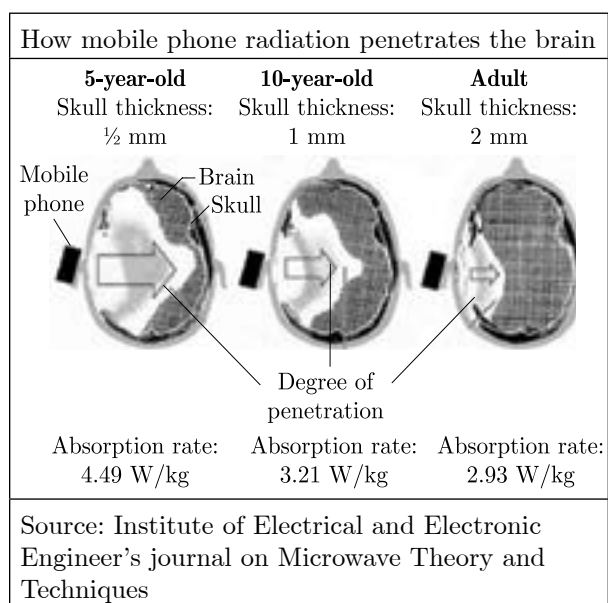

- What precautions should be taken while using mobile phones ?
- Which radiations are used in mobile phones ?
- How does prolonged heating effect due to mobile radiations can effect adversely ?
- In which part of our body, most of the heating effect occurs due to use of mobiles ?

Continue on next page.....

Click the Following Button to See the Free MS/Solutions

SOLUTIONS

SECTION-E

Question no. 37 to 39 are case-based/data -based questions with 2 to 3 short sub-parts. Internal choice is provided in one of these sub-parts.

- 37.** The reactivity series is a list of metals arranged in the order of their decreasing activities. The metal at the top of the reactivity series is the most reactive and metal at the bottom is the least reactive. The more reactive metal displaces less reactive metal from its salt solution.

K	Potassium	More reactive
Na	Sodium	
Ca	Calcium	
Mg	Magnesium	
Al	Aluminium	
Zn	Zinc	Reactivity decreases.
Fe	Iron	
Pb	Lead	
[H]	[Hydrogen]	
Cu	Copper	
Hg	Mercury	
Ag	Silver	
Au	Gold	
		Least reactive

- (i) Name the metals which react with steam but not with hot water.
 (ii) What happens when calcium reacts with nitric acid and which method is used to extract metal present at the top of the reactivity series?

or

- (ii) Which of the following metals exist in their native states in nature?
 I. Cu
 II. Au
 III. Zn
 IV. Ag

- 38.** Question numbers i - iv are based on the table given below. Study the table and answer the following questions.

Table-A

	Characters	Males	Females
1.	Total no. of chromosomes	23 pairs	23 pairs
2.	No. of autosome	22 pairs	22 pairs
3.	No. of sex chromosome	1 pair	1 pair

- (i) What is sex determination?
 (ii) What are the sex chromosomes in the males?
 (iii) What are the sex chromosomes in the females?

or

- (iv) Is the father responsible for the sex of the child?

Continue on next page.....

Click the Following Button to See the Free MS/Solutions

SOLUTIONS

39. Lenses are objects made of transparent materials such as glass or clear plastic that has curved surfaces. Diverging lenses are thicker at their edges than at their centres and makes light rays passing through them spread out. Converging lenses are thicker in their middle than at their edges and make light rays passing through them focus at a point. These are used in spectacles to help people with poor vision see better. The converging lenses magnify by bending the rays of light that pass through them to meet at a point called focus. Thicker the converging lens is at its centre, the more it magnifies and closer the focus is to the lens.

- (i) Ravi uses two lenses A and B of same size and same material as shown. P_1 and P_2 are the powers of A and B. An object is kept at the same distance from the lens between F and 2F of each lens on the principal axis in turn. Let I_1 and I_2 be the image formed by two lenses respectively. What is the relation of image distances of both lenses ?

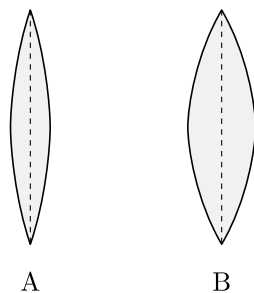

- (ii) Write down the relation between the power of lens of both lenses ?
- (iii) Meenakshi uses above two lenses A and B along with another two lenses C and D, as shown :

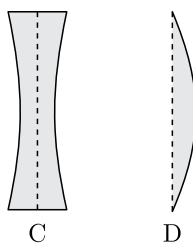

She is able to see the subject matter on the black board while sitting in the front row in the classroom but is unable to see the same matter while sitting in the last row.
Which of the above four lenses will she require to correct the defect in her vision? Why ?

or

- (iv) Natasha places an object on the principal axis of above given lens A. One end of this object coincides with the focus F and the other end with 2F. What will be the nature of the image formed by the lens on the other side ?

□□□□□□

DOWNLOAD INDIA'S BEST STUDY MOBILE APP

- 30 Sample Paper with Solutions
- Chapterwise Question Bank of All Subject
- Previous 15 Years Solved Papers
- NCERT Solutions
- Case Study Questions with full Solutions
- **Word File of Material for Teachers**

Search by **NODIA** on Play Store to Download App

Add 89056 29969 in Your Class Whatsapp Group to Get Link

Click the Following Button to See the Free MS/Solutions

SOLUTIONS

Sample Paper 6

Class X 2023-24

Science (086)

Time: 3 Hours

Max. Marks: 80

General Instructions:

1. This question paper consists of 39 questions in 5 sections.
 2. All questions are compulsory. However, an internal choice is provided in some questions. A student is expected to attempt only one of these questions.
 3. Section A consists of 20 Objective Type questions carrying 1 mark each.
 4. Section B consists of 6 Very Short questions carrying 02 marks each. Answers to these questions should be in the range of 30 to 50 words.
 5. Section C consists of 7 Short Answer type questions carrying 03 marks each. Answers to these questions should be in the range of 50 to 80 words.
 6. Section D consists of 3 Long Answer type questions carrying 05 marks each. Answer to these questions should be in the range of 80 to 120 words.
 7. Section E consists of 3 source-based/case-based units of assessment of 04 marks each with sub-parts.
-

SECTION-A

Select and write one most appropriate option out of the four options given for each of the questions 1 – 20.

1. Which of the following correctly represents graphical relation between angle of incidence (i) and angle of reflection (r) ?

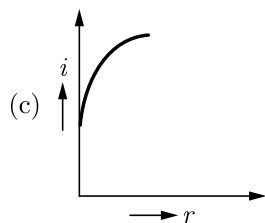
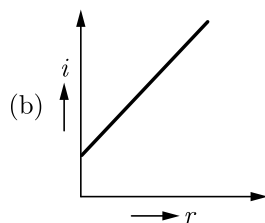
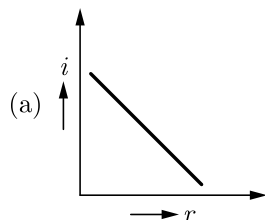

Continue on next page.....

Click the Following Button to See the Free MS/Solutions

SOLUTIONS

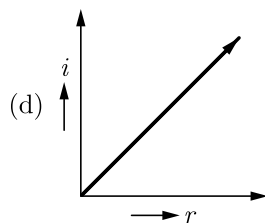

2. The reaction between carbon and oxygen can be represented as
$$\text{C(s)} + \text{O}_2\text{(g)} \xrightarrow{\Delta} \text{CO}_2\text{(g)} + \text{Heat}$$

In which of the following type(s), the above reaction can be classified?
1. Combustion reaction
 2. Displacement reaction
 3. Endothermic reaction
 4. Combination reaction
- (a) 1 and 3
(b) 1, 3 and 4
(c) 1 and 4
(d) 1 Only
3. A molecule of ammonia (NH_3) has
- only single bonds
 - only double bonds
 - only triple bonds
 - two double bonds and one single bond
4. Which of the following is used for dissolution of gold?
- Hydrochloric acid
 - Sulphuric acid
 - Nitric acid
 - Aqua regia
5. Choose the correct statement that describe the arteries?
- They have thick elastic walls, blood flows under high pressure, collect blood from different organs and bring it back to the heart.
 - They have thin walls with valves inside, blood flows under low pressure and carry blood away from the heart to various organs of the body.
 - They have thick elastic walls, blood flows under low pressure, carry blood from the heart to various organs of the body.
 - They have thick elastic walls without valves inside, blood flows under high pressure and carry blood away from the heart to different parts of the body.

Continue on next page.....

Click the Following Button to See the Free MS/Solutions

SOLUTIONS

6. What happens when a solution of an acid is mixed with a solution of a base in a jar as shown in the figure?

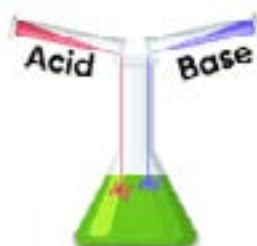

1. Salt formation takes place.
 2. The temperature of the solution remains the same.
 3. The temperature of the solution decreases.
 4. The temperature of the solution increases.
- (a) Only 1
(b) 1 and 2
(c) 2 and 4
(d) 1 and 4
7. Which of the following reaction is characterised by the yellow colour of product?
- (a) $2\text{Pb}_3\text{O}_4 \xrightarrow{\Delta} 6\text{PbO}(\text{s}) + \text{O}_2(\text{g})$
 - (b) $\text{Zn}(\text{s}) + \text{H}_2\text{SO}_4 \longrightarrow \text{ZnSO}_4 + \text{H}_2$
 - (c) $\text{Na}_2\text{CO}_3 + \text{H}_2\text{SO}_4 \longrightarrow \text{Na}_2\text{SO}_4 + \text{H}_2\text{O} + \text{CO}_2$
 - (d) $2\text{KClO}_3 \xrightarrow{\Delta} 2\text{KCl} + 3\text{O}_2(\text{g})$
8. Inorganic nitrates or nitrites helps the plants for the synthesis of:
- (a) Carbohydrates
 - (b) Nitrogen
 - (c) Carbon dioxide
 - (d) Protein
9. Twinkling of stars is due to atmospheric
- (a) dispersion of light by water droplets
 - (b) refraction of light by different layers of varying refractive indices
 - (c) scattering of light by dust particles
 - (d) internal reflection of light by clouds
10. A doctor advised a person to take an injection of insulin because
- (a) his blood pressure was low
 - (b) his heart was beating slowly
 - (c) he was suffering from goitre
 - (d) his sugar level in blood was high

Continue on next page.....

Click the Following Button to See the Free MS/Solutions

SOLUTIONS

11. The number of chromosomes in parents and offsprings of a particular species remains constant due to
- doubling of chromosomes after zygote formation
 - halving of chromosomes during gamete formation
 - doubling of chromosomes after gamete formation
 - halving of chromosomes after gamete formation
12. An object is immersed in a fluid. In order that the object becomes invisible, it should
- Behave as a perfect reflector
 - Absorb all light falling on it
 - Have refractive index one
 - Have refractive index exactly matching with that of the surrounding fluid
13. Study the following ray diagram:

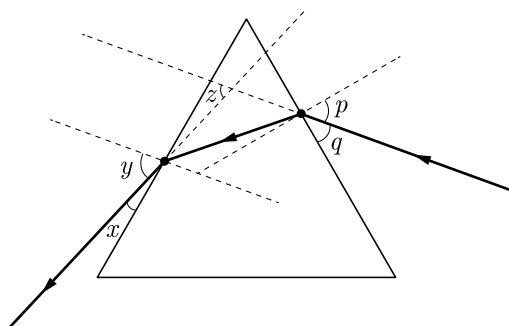

In this diagram, the angle of incidence, the angle of emergence and the angle of deviation respectively have been represented by

- y, p, z
 - x, q, z
 - p, y, z
 - p, z, y
14. Silver articles become black on prolonged exposure to air as shown in the figure. This is due to the formation of



- Ag_3N
- Ag_2O
- Ag_2S
- Ag_2S and Ag_3N

Continue on next page.....

Click the Following Button to See the Free MS/Solutions

SOLUTIONS

15. The statement of law of conservation of mass is:



- (a) mass can neither be created nor destroy.
(b) mass can be created nor destroy.
(c) mass of the body cannot be remain same.
(d) none of these.
16. Select the statements that describe characteristics of genes
- (i) genes are specific sequence of bases in a DNA molecule
(ii) a gene does not code for proteins
(iii) in individuals of a given species, a specific gene is located on a particular chromosome
(iv) each chromosome has only one gene
- (a) (i) and (ii)
(b) (i) and (iii)
(c) (i) and (iv)
(d) (ii) and (iv)

Question no. 17 to 20 are Assertion-Reasoning based questions.

17. **Assertion :** The balancing of chemical equations is based on law of conservation of mass.
Reason : Total mass of reactants is equal to total mass of products.
- (a) Both Assertion and Reason are True and Reason is the correct explanation of the Assertion.
(b) Both Assertion and Reason are True but Reason is not the Correct explanation of the Assertion.
(c) Assertion is True but the Reason is False.
(d) Both Assertion and Reason are False.
18. **Assertion :** Plant hormones are growth regulator.
Reason : Growth regulators promote or inhibit the growth.
- (a) Both assertion (A) and reason (R) are true and reason (R) is the correct explanation of assertion (A).
(b) Both assertion (A) and reason (R) are true but reason (R) is not the correct explanation of assertion (A).
(c) Assertion (A) is true but reason (R) is false.
(d) Assertion (A) is false but reason (R) is true.
19. **Assertion :** In woody plants, gaseous exchange occurs through lenticels.
Reason : Lenticels are specialised cells found along with stomata on the stem of woody plants.
- (a) Both Assertion and Reason are true and Reason is the correct explanation of Assertion.
(b) Both Assertion and Reason are true but Reason is not the correct explanation of Assertion.
(c) Assertion is true but Reason is false.
(d) Assertion is false but Reason is true.

Continue on next page.....

Click the Following Button to See the Free MS/Solutions

SOLUTIONS

20. **Assertion :** Heater wire must have high resistance will be melting point.
Reason : If resistance is high, the electric conductivity will be less.
- (a) Both assertion (A) and reason (R) are true and reason (R) is the correct explanation of assertion (A).
 - (b) Both assertion (A) and reason (R) are true but reason (R) is not the correct explanation of assertion (A).
 - (c) Assertion (A) is true but reason (R) is false.
 - (d) Assertion (A) is false but reason (R) is true.

SECTION-B

Question no. 21 to 26 are very short answer questions.

21. Name the gas which is usually produced when dil. sulphuric acid reacts with a metal. Illustrate it with an example. How will you test the evolution of this gas.

or

The soil in a field is highly acidic. List any two materials which can be added to this soil to reduce its acidity. Give the reason of your choice.

22. What are the functions of the forebrain ?
23. “The sex of the children is determined by what they inherit from their father and not their mother”. Justify.
24. Variations are important for the survival of species overtime. Justify this statement with reasons.
25. State the two laws of reflection of light.

or

A concave mirror is known as a converging mirror while a convex mirror is known as diverging mirror? Explain why ?

26. In the following food chain, 5 J of energy is available to man. How much energy was available at producer level ?

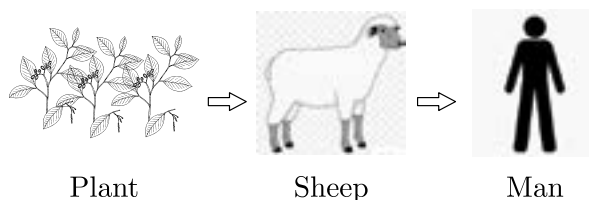

Continue on next page.....

Click the Following Button to See the Free MS/Solutions

SOLUTIONS

SECTION-C

Question no. 27 to 33 are short answer questions.

27. How does rusting take place ? Write the conditions necessary for rusting to take place.
28. Anhydrous copper sulphate (CuSO_4) was dissolved in one beaker and hydrated copper sulphate ($\text{CuSO}_4 \cdot 5\text{H}_2\text{O}$) was dissolved in another beaker. What heat changes do you expect in these beakers and why ?
29. Explain Mendel's experiment with peas on inheritance of characters considering only one visible contrasting character.

or

An angiosperm plant having red coloured flowers when crossed with the other having the same colour produced 40 progenies out of which 30 plants were with red coloured flowers 10 plants were with white colour flowers.

Finds out :

- (a) What is the possible genotype of parent plants ?
- (b) Which trait is dominated and recessive?
- (c) What is this cross called as and what is its phenotyping ratio ?
30. A person suffering from short-sightedness can see clearly only upon a distance of 2 metres. Find the nature and power of the lens required to correct his vision.
31. (a) An object is placed at the focus of a convex lens. Draw a ray diagram to locate the position of the image formed, if any state its position and nature.
- (b) An object placed 50 cm from a lens produces a virtual image at a distance of 10 cm from the lens. Find the focal length of the lens and also state the type of the lens used.
32. (a) Write the mathematical expression for Joule's law of heating.
- (b) Compute the heat generated while transferring 96000 coulomb of charge in two hours through a potential difference of 40 V.

or

Two electric lamps rated 100 W, 220 V and 25 W, 220 V are connected in parallel. Calculate the total electric current in the circuit.

33. Define an ecosystem. Draw a block diagram to show the flow of energy in an ecosystem.

Continue on next page.....

Click the Following Button to See the Free MS/Solutions

SOLUTIONS

SECTION-D

Question no. 34 to 36 are Long answer questions.

34. A metal E is stored under kerosene. When a small piece of it is left open in the air, it catches fire. When the product formed is dissolved in water it turns red litmus to blue.
- Name the metal E .
 - Write the chemical equation for the reaction when it is exposed to air and when the product is dissolved in water.
 - Explain the process by which the metal is obtained from its molten chloride.

or

- What is an ionic bond ?
 - How is an ionic bond formed ?
 - Write the formation of magnesium chloride.
35. (a) Draw the diagram of a flower to show its male and female reproductive parts. Label the following parts in it :
- Ovary
 - Anther
 - Filament
 - Stigma
- (b) How does fusion of male and female gametes take place in plants?

or

Differentiate between blood and lymph.

36. What is meant by magnetic force ? Name and explain the rule to determine the direction of force experienced by a current carrying conductor in a magnetic field. How does this force gets affected on :
- doubling the magnitude of current.
 - reversing the direction of current flow and
 - reversing the direction of magnetic field?

SECTION-E

Question no. 37 to 39 are case-based/data-based questions with 2 to 3 short sub-parts. Internal choice is provided in one of these sub-parts.

37. There are different types of chemical reactions occurring around us or being carried out for the benefit of mankind, e.g. combination reactions, decomposition reactions, displacement reactions, precipitation reactions, reduction-oxidation (redox) reactions, photochemical reactions etc.

Now, answer the following questions :

- Combustion of coke is a combination reaction. CO_2 is not a pollutant. Then, why is combustion of coke harmful?
- Which reaction followed by two combination reactions are involved in white wash of walls?
- Give one use of tin plating in daily life.

or

- How photochemical reactions have played an important in photography?

Continue on next page.....

Click the Following Button to See the Free MS/Solutions

SOLUTIONS

38. Reproduction (or procreation or breeding) is the biological process by which new individual organisms-“offspring” are produced from their “parents”. Reproduction is a fundamental feature of all known life; each individual organism exists as the result of reproduction. There are two forms of reproduction: asexual and sexual. In asexual reproduction, an organism can reproduce without the involvement of another organism. Asexual reproduction is not limited to single-celled organisms. The cloning of an organism is a form of asexual reproduction. By asexual reproduction, an organism creates a genetically similar or identical copy of itself. The evolution of sexual reproduction is a major puzzle for biologists. Sexual reproduction typically requires the sexual interaction of two specialized organisms, called gametes, which contain half the number of chromosomes of normal cells and are created by meiosis, with a male typically fertilizing a female of the same species to create a fertilized zygote. This produces offspring organisms whose genetic characteristics are derived from those of the two parental organisms. Asexual reproduction is a process by which organisms create genetically similar or identical copies of themselves without the contribution of genetic material from another organism. Bacteria divide asexually via binary fission. Sexual reproduction is a biological process that creates a new organism by combining the genetic material of two organisms in a process that starts with meiosis, a specialized type of cell division.



- (i) What do you mean by reproduction?
 - (ii) How many forms of reproduction are there? What are they?
 - (iii) What do you mean by asexual reproduction?
- or**
- (iv) What do you mean by sexual reproduction?

Continue on next page.....

Click the Following Button to See the Free MS/Solutions

SOLUTIONS

39. Mr. Rakesh was helping her daughter Aruna at home understanding about the basics of reflection of light. He found the simplest way to convey the role of curved mirrors using stainless steel teaspoon. Aruna got surprised to know that virtual image is that which can be seen but cannot be obtained on the screen. Mr. Rakesh then explained the formation of image using Ray diagrams.

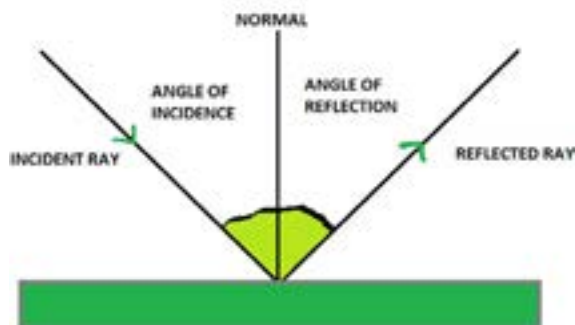

- (i) What do you mean by reflection of light?
(ii) The angle between incident ray and reflected ray is 60° . What is the value of angle of incidence?
(iii) A ray of light is incident on a plane mirror at an angle of 30° . what is the angle of reflection?
or
(iv) What happens to a light ray that is incident normally on a surface?

□□□□□□

DOWNLOAD INDIA'S BEST STUDY MOBILE APP

- 30 Sample Paper with Solutions
- Chapterwise Question Bank of All Subject
- Previous 15 Years Solved Papers
- NCERT Solutions
- Case Study Questions with full Solutions
- **Word File of Material for Teachers**

Search by **NODIA** on Play Store to Download App

Add 89056 29969 in Your Class Whatsapp Group to Get Link

Click the Following Button to See the Free MS/Solutions

SOLUTIONS

Sample Paper 7

Class X 2023-24

Science (086)

Time: 3 Hours

Max. Marks: 80

General Instructions:

1. This question paper consists of 39 questions in 5 sections.
 2. All questions are compulsory. However, an internal choice is provided in some questions. A student is expected to attempt only one of these questions.
 3. Section A consists of 20 Objective Type questions carrying 1 mark each.
 4. Section B consists of 6 Very Short questions carrying 02 marks each. Answers to these questions should be in the range of 30 to 50 words.
 5. Section C consists of 7 Short Answer type questions carrying 03 marks each. Answers to these questions should be in the range of 50 to 80 words.
 6. Section D consists of 3 Long Answer type questions carrying 05 marks each. Answer to these questions should be in the range of 80 to 120 words.
 7. Section E consists of 3 source-based/case-based units of assessment of 04 marks each with sub-parts.
-

SECTION-A

Select and write one most appropriate option out of the four options given for each of the questions 1 – 20.

1. In given figure, a light ray AB is incident normally on one face PQ of an equilateral glass prism. The angles at faces PR is:

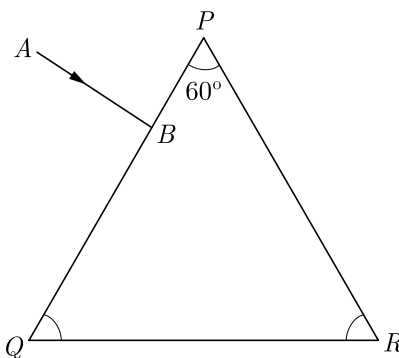

- (a) 60°
(b) 30°
(c) 45°
(d) 90°
2. Which one of the following involve a chemical reaction?
(a) Heating magnesium wire in the presence of air at high temperature
(b) Evaporation of water
(c) Storing on nitrogen gas under pressure
(d) Keeping petrol in a China dish in open

Continue on next page.....

Click the Following Button to See the Free MS/Solutions

SOLUTIONS

3.



If copper is kept open in air, it slowly loses its shining brown surface and gains a green coating as shown in the figure. It is due to the formation of

- (a) CuSO_4
- (b) CuCO_3
- (c) $\text{Cu}(\text{NO}_3)_2$
- (d) CuO

4.



Calcium phosphate is present in tooth enamel. Its nature is

- (a) basic
- (b) acidic
- (c) neutral
- (d) amphoteric

5. Sodium hydrogen carbonate when added to acetic acid evolves a gas. Which of the following statements are true about the gas evolved?

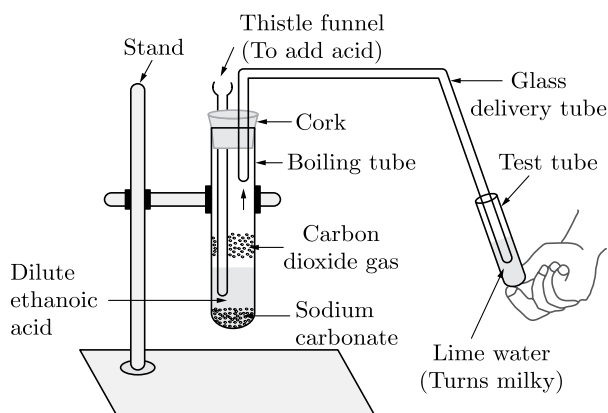

Continue on next page.....

Click the Following Button to See the Free MS/Solutions

SOLUTIONS

1. It turns lime water milky.
 2. It extinguishes a burning splinter.
 3. It dissolves in a solution of sodium hydroxide.
 4. It has a pungent odour.
- (a) 1 and 2
(b) 1, 2 and 3
(c) 2, 3 and 4
(d) 1 and 4
6. Two thin lenses of power $+3.5\text{ D}$ and -2.5 D are placed in contact. The power of the lens combination is-
- (a) $+1\text{ D}$
(b) $+1.5\text{ D}$
(c) $+2.5\text{ D}$
(d) $+2\text{ D}$
7. Carbon exists in the atmosphere in the form of
- (a) Carbon monoxide only
(b) Carbon monoxide in traces and carbon dioxide
(c) Carbon dioxide only
(d) Coal
8. A ray of light is refracted as per the following diagram. Which of the following medium is optically denser?

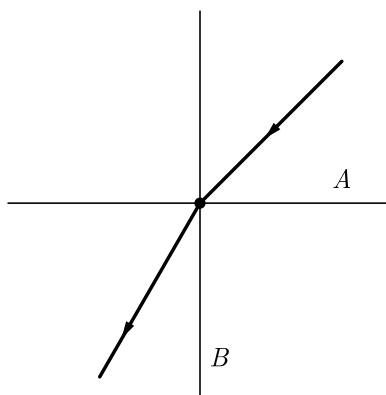

- (a) Medium A
(b) Medium B
(c) Cannot be identified
(d) Both medium are denser
9. Which of the following is the correct route for blood flow in a human?
- (a) Right atrium \rightarrow Right ventricle \rightarrow Lungs \rightarrow Left atrium \rightarrow Left ventricle
(b) Right atrium \rightarrow Right ventricle \rightarrow Left ventricle \rightarrow Left atrium \rightarrow Lungs
(c) Left atrium \rightarrow Left ventricle \rightarrow Right ventricle \rightarrow Right atrium \rightarrow Lungs
(d) Left atrium \rightarrow Left ventricle \rightarrow Lungs \rightarrow Right ventricle \rightarrow Right atrium

Continue on next page.....

Click the Following Button to See the Free MS/Solutions

SOLUTIONS

10.

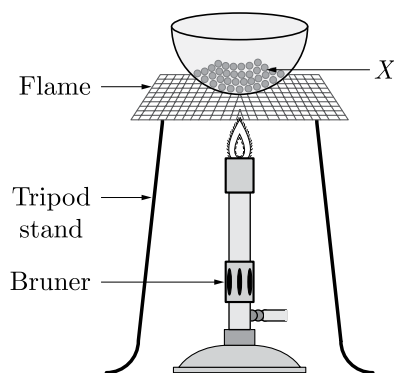

A shiny brown coloured element X on heating in air becomes black in colour as shown in the figure. Here X is:

- (a) Copper
 - (b) Silver
 - (c) Aluminium
 - (d) Mercury
11. Just as CO_2 is removed from the blood in the lungs, nitrogenous waste such as urea or uric acid are removed from blood in the -
- (a) Kidney
 - (b) Urinary bladder
 - (c) Urethra
 - (d) Ureters
12. Which of the following phenomena of light are involved in the formation of a rainbow?
- (a) Reflection, refraction and dispersion.
 - (b) Reflection, dispersion and total internal reflection.
 - (c) Refraction, dispersion and internal reflection.
 - (d) Dispersion, scattering and total internal reflection.
13. A zygote which has an X-chromosome inherited from the father will develop into a
- (a) boy
 - (b) girl
 - (c) X-chromosome does not determine the sex of a child
 - (d) either boy or girl
14. Which of the following statements about the given reaction are correct?
- $$3\text{Fe}(\text{s}) + 4\text{H}_2\text{O}(\text{g}) \longrightarrow \text{Fe}_3\text{O}_4(\text{s}) + 4\text{H}_2(\text{g})$$
- 1. Iron metal is getting oxidised.
 - 2. Water is getting reduced.
 - 3. Water is acting as reducing agent.
 - 4. Water is acting as oxidising agent.
- (a) 1, 2 and 3
 - (b) 3 and 4
 - (c) 1, 2 and 4
 - (d) 2 and 4

Continue on next page.....

Click the Following Button to See the Free MS/Solutions

SOLUTIONS

15. Dramatic changes of body features associated with puberty are mainly because of secretion of
- estrogen from testes and testosterone from ovary
 - estrogen from adrenal gland and testosterone from pituitary gland
 - testosterone from testes and estrogen from ovary
 - testosterone from thyroid gland and estrogen from pituitary gland
16. Offspring formed as a result of sexual reproduction exhibits more variations because
- sexual reproduction is a lengthy process
 - genetic material comes from two parents of the same species
 - genetic material comes from two parents of different species
 - genetic material comes from many parents

Question no. 17 to 20 are Assertion-Reasoning based questions.

17. **Assertion :** Decomposition reactions are similar to combination reactions.
Reason : Both reactions need a catalyst to occur.
- Both Assertion and Reason are True and Reason is the correct explanation of the Assertion.
 - Both Assertion and Reason are True but Reason is not the Correct explanation of the Assertion.
 - Assertion is True but the Reason is False.
 - Both Assertion and Reason are False.
18. **Assertion :** Reflex actions are automatic and repid responses to stimuli.
Reason : These actions are controlled by brain.
- Both assertion (A) and reason (R) are true and reason (R) is the correct explanation of assertion (A).
 - Both assertion (A) and reason (R) are true but reason (R) is not the correct explanation of assertion (A).
 - Assertion (A) is true but reason (R) is false.
 - Assertion (A) is false but reason (R) is true.
19. **Assertion :** Amoeba is not an omnivore organism.
Reason : Lion is a carnivore organism.
- Both Assertion and Reason are true and Reason is the correct explanation of Assertion.
 - Both Assertion and Reason are true but Reason is not the correct explanation of Assertion.
 - Assertion is true but Reason is false.
 - Assertion is false but Reason is true.
20. **Assertion :** The connecting wires are made of copper.
Reason : The electrical conductivity of copper is high.
- Both assertion (A) and reason (R) are true and reason (R) is the correct explanation of assertion (A).
 - Both assertion (A) and reason (R) are true but reason (R) is not the correct explanation of assertion (A).
 - Assertion (A) is true but reason (R) is false.
 - Assertion (A) is false but reason (R) is true.

Continue on next page.....

Click the Following Button to See the Free MS/Solutions

SOLUTIONS

SECTION-B

Question no. 21 to 26 are very short answer questions.

21. Tooth enamel is one of the hardest substances in our body. How does it undergo damage due to eating chocolates and sweets ? How do tooth pastes prevent this damage ?

or

Three solutions A , B and C have pH values of 6, 2 and 10 respectively. Which of the solutions is highly acidic? Which solution will turn red litmus blue ?

22. Where does cerebrospinal fluid occur in our body ? Mention its function.

23. What is a sex chromosome ?

24. What is the basic event in reproduction?

25. Identify the nature of the mirror and mention two characteristics of the image formed when magnification $(m) = +6$.

or

Where should an object be placed in front of a concave mirror of focal length 20 cm so as to obtain a two times magnified real image ?

26. In a certain study conducted on occurrence of DDT along food chains in an ecosystem, the concentration of DDT in grass was found to be 0.5 ppm (parts per million), in sheep it was 2 ppm and in man it was 10 ppm. Why was the concentration of DDT maximum in case of man ?

SECTION-C

Question no. 27 to 33 are short answer questions.

27. How does the activity series of metals help us in predicting the relative reactivity of metals ?

28. Name three chemical reactions in which heat is evolved and three chemical reactions in which heat is absorbed.

29. Explain the feedback mechanism to regulate the action of the hormones with the help of one suitable example.

or

Nervous and hormonal system together per the function of control and coordination in human beings. Justify the statement.

30. State the cause of dispersion of white light by a glass prism. How did Newton using two identical glass prism, show that white light is made of seven colours ? Draw a ray diagram to show the path of a narrow beam of white light through a combination of two identical prisms arranged together in inverted position with respect to each other when it is allowed to fall obliquely on one of the faces of the first prism of the combination ?

Continue on next page.....

Click the Following Button to See the Free MS/Solutions

SOLUTIONS

31. Due to gradual weakening of ciliary muscles and diminishing flexibility of the eye lens a certain defect of vision arises. Write the name of this defect. Name the type of lens required by such persons to improve the vision. Explain the structure and function of such a lens.
32. A hot plate of an electric oven, connected to a 200 V line. It has two resistance coils A and B each of the $30\ \Omega$ which may be used separately, in series or in parallel. Find the value of the current required in each of the three cases.
- or**
- State the formula co-relating the electric current flowing in a conductor and the voltage applied across it. Also show this relationship by drawing a graph.
What would be the resistance of a conductor if the current flowing through it is 0.35 ampere when the potential difference across it is 1.4 volt ?
33. (a) What are decomposers ?
(b) State in brief the role of decomposers in the environment.

SECTION-D

Question no. 34 to 36 are Long answer questions.

34. Account for the following
- (a) State the relation between hydrogen ion concentration of an aqueous solution and its pH.
 - (b) An aqueous solution has a pH value of 7.0. Is this solution acidic, basic or neutral.
 - (c) Which has a higher pH value, 1 M HCl or 1 M NaOH solution ?
 - (d) Tooth enamel is one of the hardest substances in our body. How does it undergo damage due to eating chocolates and sweets ? What should we do to prevent it.
 - (e) How do $[H^+]$ ions exist in water ?
- or**
- (a) A liquid has a pH less than 7 which represents an acidic solution.
 - (i) State the nature of solution, if its pH increases from 7 to 14.
 - (ii) Mention the ion whose concentration increases with the increase in pH value.
 - (iii) Suggest a method that is generally used for measuring pH value.
 - (b) Give reason for the following :
 - (i) Tooth decay starts when the pH of the mouth is lower than 5.5.
 - (ii) Antacids are used for treatment of indigestion.
35. Explain with the help of diagram. Also, indicate what happens to the rate of photosynthesis if stomata get blocked due to dust.
- or**
- Why is respiration important for all living organisms?
36. Briefly explain an activity to plot the magnetic field lines around a bar magnet. Sketch the field pattern for the same specifying field directions.
A region A has magnetic field lines relatively closer than another region B . Which region has stronger magnetic field ? Give reason to support your answer.

Continue on next page.....

Click the Following Button to See the Free MS/Solutions

SOLUTIONS

SECTION-E

Question no. 37 to 39 are case-based/data -based questions with 2 to 3 short sub-parts. Internal choice is provided in one of these sub-parts.

37. When two or more substances react and form some new substance, it is called a chemical reaction. Chemical equation is represented in terms of symbols, molecular formulas, moles, states, etc. As we know, all chemical reaction obeys law of chemical combination. Therefore, chemical reactions need to be balanced. It is done by hit and trial method. The chemical reactions can be classified into different types such as combination reaction, decomposition reaction, displacement reaction, double displacement reaction. The reactions take place in solution is precipitation reactions and neutralisation reactions.



- (i) Define a chemical equation.
(ii) Which law is followed by all chemical reactions?
(iii) Name four types of chemical reactions.
- or**
- (iv) Give example of precipitation reactions.
38. Reproduction in human beings is by sexual reproduction where both the male and female gametes fertilise to give rise to an embryo. The fertilization of the human embryo occurs inside the body of the female.



Continue on next page.....

Click the Following Button to See the Free MS/Solutions

SOLUTIONS

- (i) Name the part of the male reproductive system where the formation of sperms takes place.
 (ii) What is the placenta?
 (iii) What is the other name of the oviduct?

or

- (iv) Define the term implantation.

39. A near sighted person wears eye glass with power of -5.0 D for distant vision. Soon, he started having difficulties in viewing nearby objects also. His doctor prescribes a correction of $+1.5$ D in near vision section of his bi-focal, which is measured relative to main part of the lens.

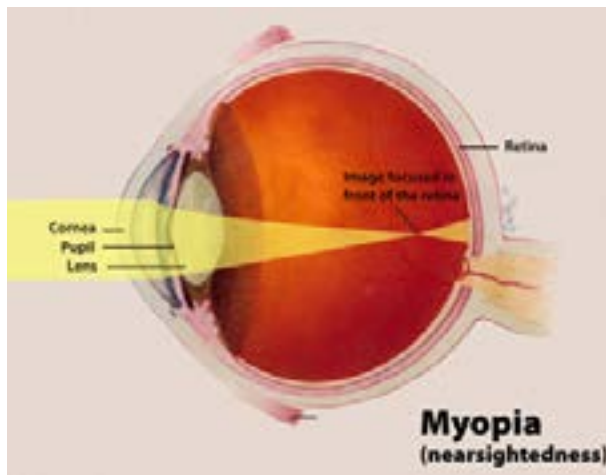

- (i) Find the focal length of his distant viewing part of lens.
 (ii) Find the focal length of near vision section of the lens.
 (iii) What type of lens is to be used in this spectacles for near vision ?

or

- (iv) What is the reason of hypermetropia ?

□□□□□□

DOWNLOAD INDIA'S BEST STUDY MOBILE APP

- 30 Sample Paper with Solutions
- Chapterwise Question Bank of All Subject
- Previous 15 Years Solved Papers
- NCERT Solutions
- Case Study Questions with full Solutions
- **Word File of Material for Teachers**

Search by **NODIA** on Play Store to Download App

Add 89056 29969 in Your Class Whatsapp Group to Get Link

Click the Following Button to See the Free MS/Solutions

SOLUTIONS

Sample Paper 8

Class X 2023-24

Science (086)

Time: 3 Hours

Max. Marks: 80

General Instructions:

1. This question paper consists of 39 questions in 5 sections.
2. All questions are compulsory. However, an internal choice is provided in some questions. A student is expected to attempt only one of these questions.
3. Section A consists of 20 Objective Type questions carrying 1 mark each.
4. Section B consists of 6 Very Short questions carrying 02 marks each. Answers to these questions should be in the range of 30 to 50 words.
5. Section C consists of 7 Short Answer type questions carrying 03 marks each. Answers to these questions should be in the range of 50 to 80 words.
6. Section D consists of 3 Long Answer type questions carrying 05 marks each. Answer to these questions should be in the range of 80 to 120 words.
7. Section E consists of 3 source-based/case-based units of assessment of 04 marks each with sub-parts.

SECTION-A

Select and write one most appropriate option out of the four options given for each of the questions 1 – 20.

1. The diagram shows part of the human gas exchange system.

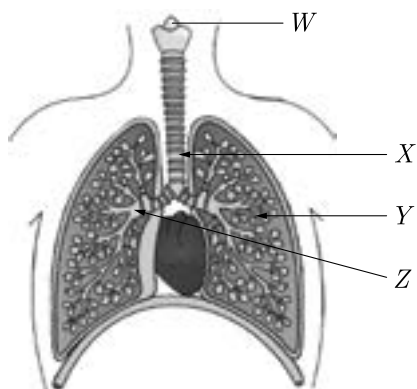

Here, *W*, *X*, *Y* and *Z* are?

	Bronchus	Bronchiole	Larynx	Trachea
(a)	<i>W</i>	<i>X</i>	<i>Z</i>	<i>Y</i>
(b)	<i>X</i>	<i>Z</i>	<i>Y</i>	<i>W</i>
(c)	<i>Y</i>	<i>W</i>	<i>X</i>	<i>Z</i>
(d)	<i>Z</i>	<i>Y</i>	<i>W</i>	<i>X</i>

Continue on next page.....

Click the Following Button to See the Free MS/Solutions

SOLUTIONS

2. The reproductive life of a woman lasts from hacreemn to spauoemen
- reproductive life a woman lasts from menarche to menopause.
 - reproductive life a woman lasts from menarche to menopause.
 - reproductive life a woman lasts from chenmare to pausemeno.
 - reproductive life a woman lasts from chenmare to usemenopa.

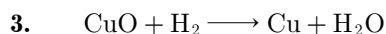

Which of the following pair is correct regarding to oxidation and reduction?

	Oxidation	Reduction
(a)	CuO	H ₂
(b)	H ₂	CuO
(c)	H ₂ O	H ₂
(d)	H ₂	H ₂ O

4. The proper representation of series combination of cells (Figure) obtaining maximum potential is

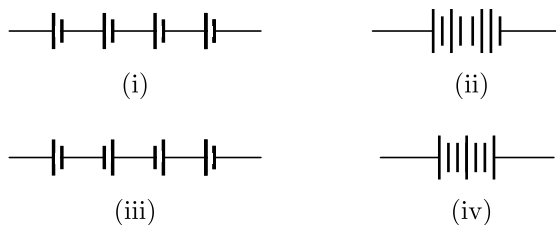

- (i)
 - (ii)
 - (iii)
 - (iv)
5. The given diagram represents a reaction.

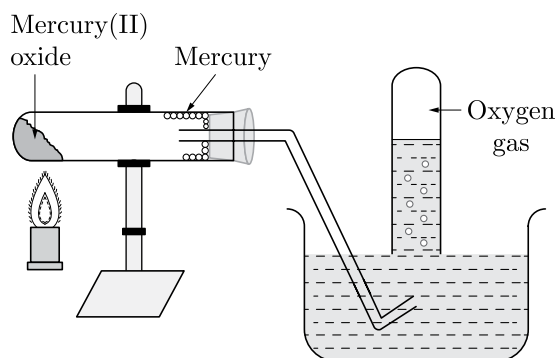

- Thermal decomposition
- Displacement
- Double displacement
- Combination

Continue on next page.....

Click the Following Button to See the Free MS/Solutions

SOLUTIONS

6. Each gamete carries only one allele. This is proposed in which law ?

- (a) law of dominance
- (b) law of segregation
- (c) law of genetics
- (d) law of assortment

7. Complete the following chemical reaction with correct option:



- (a) PbI_2
- (b) PbNO_3
- (c) $\text{Pb}(\text{NO}_3)_2$
- (d) PbIO_3

8. Which of the following are correct structural isomers of butane ?

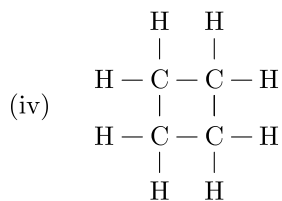
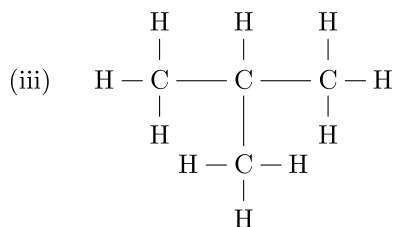
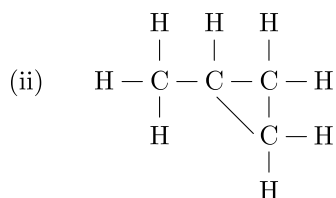
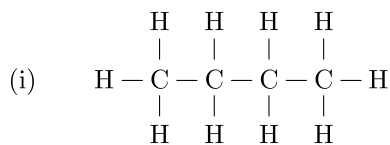

- (a) (i) and (iii)
- (b) (i) and (ii)
- (c) (ii) and (iv)
- (d) (iii) and (iv)

Continue on next page.....

Click the Following Button to See the Free MS/Solutions

SOLUTIONS

9. When pH strip is dipped in each bottle, the colour shown by bottle *A* and *B* will be respectively:

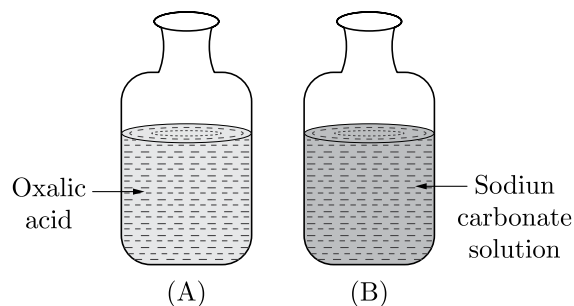

- (a) orange, blue
(b) blue, orange
(c) green, blue
(d) blue, green
10. Which of the following factors affect the strength of force experience by a current carrying conductor in a uniform magnetic field?
(a) magnetic field strength
(b) magnitude of current in a conductor
(c) length of the conductor within magnetic field
(d) All of above.
11. Which process is shown by the following picture?

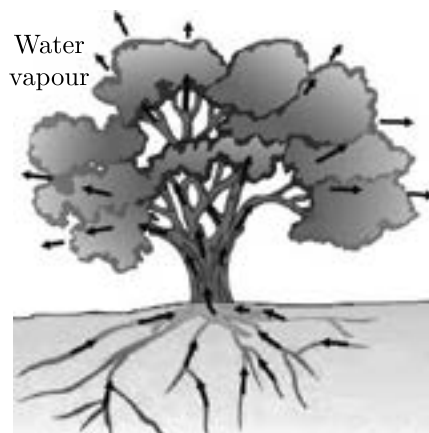

- (a) Movement of food during photosynthesis in a tree
(b) Movement of water during transpiration in a tree
(c) Movement of minerals during in a tree
(d) Movement of carbon dioxide during in a tree
12. Ionic compound have high melting point due to
(a) Strong force of attraction between oppositely charged ions.
(b) Less force of attraction between oppositely charged ions.
(c) Strong force of attraction between similar charged ions.
(d) None of these

Click the Following Button to See the Free MS/Solutions

SOLUTIONS

13. Which of the following statements about transmission of nerve impulse is incorrect ?
- Nerve impulse travels from dendritic end towards axonal end.
 - At the dendritic end electrical impulses bring about the release of some chemicals which generate an electrical impulse at the axonal end of another neuron.
 - The chemicals released from the axonal end of one neuron cross the synapse and generate a similar electrical impulse in a dendrite of another neuron.
 - A neuron transmits electrical impulses not only to another neuron but also to muscle and gland cells.
14. Electrical resistivity of a given metallic wire depends upon
- its length
 - its thickness
 - its shape
 - nature of the material
15. Which of the following substances will not give carbon dioxide on treatment with dilute acid?
- Marble
 - Limestone
 - Baking soda
 - Lime
16. In the arrangement shown in Figure, there are two coils wound on a non-conducting cylindrical rod. Initially the key is not inserted. Then the key is inserted and later removed. Then

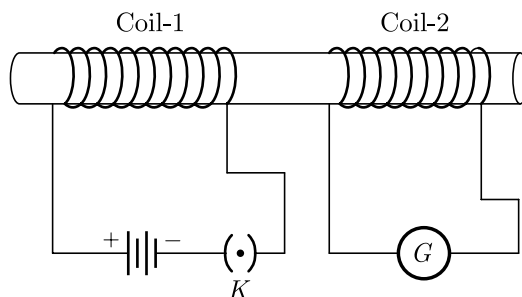

- the deflection in the galvanometer remains zero throughout
- there is a momentary deflection in the galvanometer but it dies out shortly and there is no effect when the key is removed
- there are momentary galvanometer deflections that die out shortly; the deflections are in the same direction.
- there are momentary galvanometer deflection that die out shortly; the deflections are in opposite directions

Question no. 17 to 20 are Assertion - Reasoning based questions.

17. **Assertion :** When iron nail is dipped in copper sulphate solution, the iron nail becomes brownish in colour and the blue colour of copper solution fade.
- Reason :** Equation representing this change is
- $$\text{Cu} + \text{FeSO}_4 \longrightarrow \text{CuSO}_4 + \text{Fe}$$
- Both Assertion and Reason are True and Reason is the correct explanation of the Assertion.
 - Both Assertion and Reason are True but Reason is not the Correct explanation of the Assertion.
 - Assertion is True but the Reason is False.
 - Both Assertion and Reason are False.

Click the Following Button to See the Free MS/Solutions

SOLUTIONS

18. **Assertion :** Chromosomes are known as hereditary vehicles.
Reason : The chromosomes are capable of self-reproduction and maintaining morphological and physiological properties through successive generations.
- Both assertion (A) and reason (R) are true and reason (R) is the correct explanation of assertion (A).
 - Both assertion (A) and reason (R) are true but reason (R) is not the correct explanation of assertion (A).
 - Assertion (A) is true but reason (R) is false.
 - Assertion (A) is false but reason (R) is true.
19. **Assertion :** Ethanol is obtained during the anaerobic process of respiration.
Reason : This is due to presence of oxygen and it takes place in the mitochondria.
- Both Assertion and Reason are true and Reason is the correct explanation of Assertion.
 - Both Assertion and Reason are true but Reason is not the correct explanation of Assertion.
 - Assertion is true but Reason is false.
 - Both Assertion and Reason are false.
20. **Assertion :** A current carrying conductor experiences a force in a magnetic field.
Reason : The force acting on a current carrying conductor in a magnetic field is due to interaction between magnetic field produced by the current carrying conductor and external magnetic field in which the conductor is placed.
- Both assertion (A) and reason (R) are true and reason (R) is the correct explanation of assertion (A).
 - Both assertion (A) and reason (R) are true but reason (R) is not the correct explanation of assertion (A).
 - Assertion (A) is true but reason (R) is false.
 - Assertion (A) is false but reason (R) is true.

SECTION-B

Question no. 21 to 26 are very short answer questions.

21. Pratyush took sulphur powder on a spatula and heated it. He collected the gas evolved by inverting a test tube over it as shown in Figure below :
- What will be the action of gas on
 - dry litmus paper ?
 - moist litmus paper ?

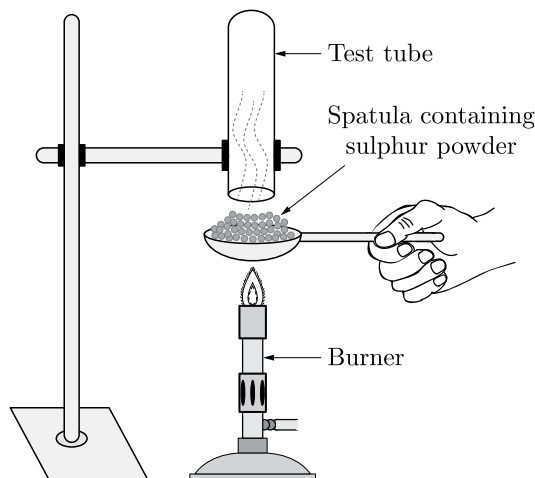

or

Write some uses of metals which are based on the properties of malleability and ductility.

Click the Following Button to See the Free MS/Solutions

SOLUTIONS

22. (a) What will happen to the guard cells and stomatal pore when water flows to guard cells ?
(b) How do plants transmit informations from cell to cell ?
23. What is the compensation point with relation to the release of CO_2 by the plants ?
24. What is the cause of peptic ulcer ?
25. A person is not able to see distinctly the objects placed beyond 90 cm from him. Giving reasons to identify the defect in his eye. Determine the nature of lens used to correct this defect.
- or**
- A star appears on the horizon. What is the true position of the star ? Explain with the help of a diagram.
26. "Energy flow in a food chain is unidirectional." Justify this statement.

SECTION-C

Question no. 27 to 33 are short answer questions.

27. Identify the type of each of the following reactions stating reason for your answers :
- (a) $\text{Fe}_2\text{O}_3 + 2\text{Al} \rightarrow \text{Al}_2\text{O}_3 + 2\text{Fe} + \text{heat}$
(b) $\text{Pb}(\text{NO}_3)_2 + 2\text{Kl} \rightarrow \text{Pbl}_2 + 2\text{KNO}_3$
(c) $\text{ZnCO}_3 \xrightarrow{\text{heat}} \text{ZnO} + \text{CO}_2$
28. Explain the following statements :
- (a) Most metal oxides are insoluble in water but some of these dissolve in water. What are these oxides and their solutions in water called ?
(b) At ordinary temperature the surface of metals such as magnesium, aluminium, zinc etc., is covered with a thin layer. What is the composition of this layer ? State its importance.
(c) Some alkali metals can be cut with a knife.
29. Study the picture carefully and answer the following:

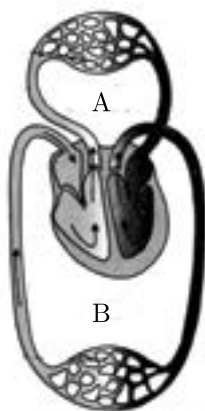

Continue on next page.....

Click the Following Button to See the Free MS/Solutions

SOLUTIONS

- (a) What does diagram given below depict?
- (b) What are A and B ?
- (c) Which vessel carried deoxygenated blood to lungs and which vessel brings oxygenated blood from lungs to heart ?

or

How does small intestine tissues help the digestion of fats, protein and starch?

30. (a) State the relationship between focal length and radius of curvature of a spherical mirror.
(b) Why is the refractive index of a medium always greater than one ?
(c) A lens has -4 D power. Is the lens concave or convex ?
31. (a) Define power of a lens and write its S.I. unit.
(b) A convex lens of power 4 D is placed at a distance of 40 cm from a wall. At what distance from the lens should a candle be placed so that its image is formed on the wall ?
32. A shining metal M , of burning gives a dazzling white flame and changes to a white powder N .
(a) Identify M and N .
(b) Represent the above reaction in the form of a balanced chemical equation.
(c) Does M undergo oxidation or reduction in this reaction ? Justify.

or

Write the equations for the following metals which are obtained from their compounds by reduction process.

- (a) Metal X which is low in reactivity series.
 - (b) Metal Y which is in middle of series.
33. Larger animals kill the smaller animals in the forest, eat whatever they can, leave the rest in the forest but the forest is never found full of dead animals. What happens to the bodies of these dead animals?

SECTION-D

Question no. 34 to 36 are Long answer questions.

34. Soaps and detergents are both types of salts. State the difference between the two. Write the mechanism of the cleaning action of soap. Why do soaps not form lather with hard water ? Mention any two problems that arise due to the use of detergents instead of soaps.

or

An organic compound with molecular formula $\text{C}_2\text{H}_4\text{O}_2$, produces brisk effervescence on addition of sodium carbonate bicarbonate.

- (a) Identify the organic compound
 - (b) Name the gas evolved.
 - (c) How will you test the gas evolved ?
 - (d) Write a chemical equation for the above reaction.
 - (e) List two important uses of the above compound.
35. (a) Differentiate between germination and fertilization.
(b) State in brief the functions of the following parts of the human male reproductive system :
(i) Scrotum
(ii) Testes
(iii) Vas deferens

Continue on next page.....

Click the Following Button to See the Free MS/Solutions

SOLUTIONS

or

- (a) Draw a neat diagram to show fertilization in a flower and label on it the following parts :
- Stigma
 - Pollen tube
 - Ovary
- State the function of pollen tube.
- (b) List in tabular form any two differences between a male gamete and a female gamete.

36. (a) For the combination of resistors shown in the following figure, find the equivalent resistance between M and N .

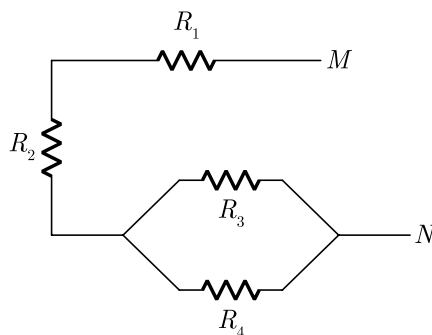

- State Joule's law of heating.
- Why we need a 5 A fuse for an electric iron which consumes 1 kW power at 220 V?
- Why is it impracticable to connect an electric bulb and an electric heater in series?

SECTION-E

Question no. 37 to 39 are case-based/data -based questions with 2 to 3 short sub-parts. Internal choice is provided in one of these sub-parts.

37. Sample of four metals P, Q, R and S were taken and added to the following solution one by one. The results obtained have been tabulated as follows.

Metal	FeSO_4	CuSO_4	ZnSO_4	AgNO_3
P	No reaction	Displacement
Q	Displacement		No reaction	Displacement
R	No reaction	No reaction	No reaction	
S	No reaction	No reaction	No reaction	No reaction

- Which is the most reactive metal ?
- What would you observe if Q is added to a solution of CuSO_4 . Also, what is the colour change when Q is added to FeSO_4 .

or

What do you mean by displacement reaction ?

Continue on next page.....

Click the Following Button to See the Free MS/Solutions

SOLUTIONS

38. Question numbers i - iv are based on the table given below. Study the table and answer the following questions.

Table-A

S. No.	Generation	Phenotypic ratio
1.	F ₁ generation	23 pairs
2.	F ₂ generation	22 pairs

- (i) State the law of dominance.
 (ii) What is the dominant allele?
 (iii) Define the term phenotype.

or

- (iv) What is the meaning of genotype ?

39. A concave mirror forms image of an object thrice in its size on a screen. Magnification of a mirror gives information about the size of the image relative to the object. It is defined as the ratio of size of image to the size of object. It is represented by m .

$$m = \frac{\text{Size of image}}{\text{Size of object}}$$

Sign of magnification by mirror gives the information about the nature of the image produce by it.

- (i) Describe the nature of image formed.
 (ii) If the object x distance from the pole of mirror, then find image distance from the pole.
 (iii) If the radius of curvature of mirror is R, then write the relation between object distance, image distance and focal length of the mirror.

or

- (iv) Give one use of concave mirror.

□□□□□□

DOWNLOAD INDIA'S BEST STUDY MOBILE APP

- 30 Sample Paper with Solutions
- Chapterwise Question Bank of All Subject
- Previous 15 Years Solved Papers
- NCERT Solutions
- Case Study Questions with full Solutions
- **Word File of Material for Teachers**

Search by **NODIA** on Play Store to Download App

Add 89056 29969 in Your Class Whatsapp Group to Get Link

Click the Following Button to See the Free MS/Solutions

SOLUTIONS

Sample Paper 9

Class X 2023-24

Science (086)

Time: 3 Hours

Max. Marks: 80

General Instructions:

1. This question paper consists of 39 questions in 5 sections.
2. All questions are compulsory. However, an internal choice is provided in some questions. A student is expected to attempt only one of these questions.
3. Section A consists of 20 Objective Type questions carrying 1 mark each.
4. Section B consists of 6 Very Short questions carrying 02 marks each. Answers to these questions should be in the range of 30 to 50 words.
5. Section C consists of 7 Short Answer type questions carrying 03 marks each. Answers to these questions should be in the range of 50 to 80 words.
6. Section D consists of 3 Long Answer type questions carrying 05 marks each. Answer to these questions should be in the range of 80 to 120 words.
7. Section E consists of 3 source-based/case-based units of assessment of 04 marks each with sub-parts.

SECTION-A

Select and write one most appropriate option out of the four options given for each of the questions 1–20.

1.

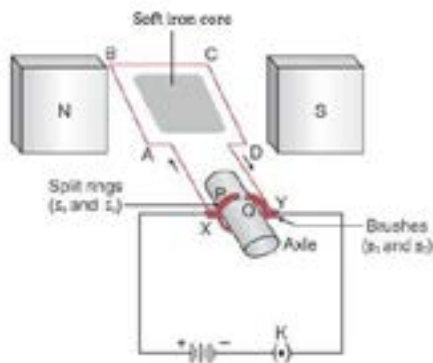

Commercial electric motors do not use

- (a) an electromagnet to rotate the armature
 - (b) effectively large number of turns of conducting wire in the current carrying coil
 - (c) a permanent magnet to rotate the armature
 - (d) a soft iron core on which the coil is wound
2. 2 mL each of concentrated HCl, HNO₃ and a mixture of concentrated HCl and concentrated HNO₃ in the ratio of 3 : 1 were taken in test tubes labelled as A, B and C. A small piece of metal was put in each test tube. No change occurred in test tubes A and B but the metal got dissolved in test tube C respectively. The metal could be
- (a) Al
 - (b) Au
 - (c) Cu
 - (d) Pt

Click the Following Button to See the Free MS/Solutions

SOLUTIONS

3. Which of the following are exothermic processes?
1. Reaction of water with quick lime.
 2. Dilution of an acid.
 3. Evaporation of water.
 4. Sublimation of camphor (crystals).
- (a) 1 and 2
(b) 2 and 3
(c) 1 and 4
(d) 3 and 4
4. Which of the following are present in a dilute aqueous solution of hydrochloric acid?
- (a) $\text{H}_3\text{O}^+ + \text{Cl}^-$
(b) $\text{H}_3\text{O}^+ + \text{OH}^-$
(c) $\text{Cl}^- + \text{OH}^-$
(d) Unionised HCl
5. Which of the following statements are true for flowers?



- (i) Flowers are always bisexual
(ii) They are the sexual reproductive organs
(iii) They are produced in all groups of plants
(iv) After fertilisation they give rise to fruits
- (a) (i) and (iv)
(b) (ii) and (iii)
(c) (i) and (iii)
(d) (ii) and (iv)
6. Which of the following is/are correct for diluting acid?



Continue on next page.....

Click the Following Button to See the Free MS/Solutions

SOLUTIONS

1. Adding acid to water by stirring.
 2. Adding water to acid by stirring.
- (a) Only 1
 - (b) Only 2
 - (c) Both 1 and 2
 - (d) Neither 1 nor 2
7. Which among the following are unsaturated hydrocarbons ?
- (i) $\text{H}_3\text{C} - \text{CH}_2 - \text{CH}_2 - \text{CH}_3$
 - (ii) $\text{H}_3\text{C} - \text{C} \equiv \text{C} - \text{CH}_3$
 - (iii) $\text{H}_3\text{C} - \underset{\text{CH}_3}{\text{CH}} - \text{CH}_3$
 - (iv) $\text{H}_3\text{C} - \underset{\text{CH}_3}{\text{C}} = \text{CH}_2$
- (a) (i) and (iii)
 - (b) (ii) and (iii)
 - (c) (ii) and (iv)
 - (d) (iii) and (iv)
8. A solution of substance X is used for white washing. Here X is:
- (a) CaO
 - (b) CaO_2
 - (c) NaCl
 - (d) KCl
- 9.

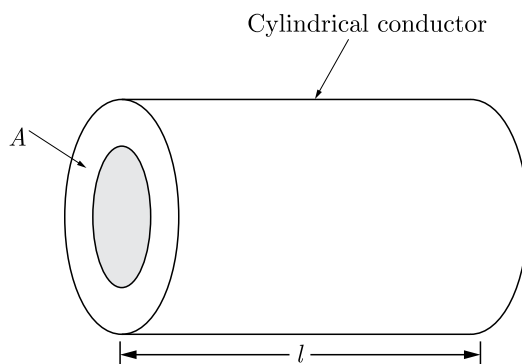

A cylindrical conductor of length l and uniform area of cross-section A has resistance R . Another conductor of length $2l$ and resistance R of the same material has area of cross section

- (a) $A/2$
- (b) $3A/2$
- (c) $2A$
- (d) $3A$

Continue on next page.....

Click the Following Button to See the Free MS/Solutions

SOLUTIONS

10. When hydrogen sulphide gas is passed through a blue solution of copper sulphate, a black precipitate of copper sulphide is obtained and the sulphuric acid so formed remains in the solution. The reaction is an example of-
- (a) a combination reaction
 - (b) a displacement reaction
 - (c) a decomposition reaction
 - (d) a double decomposition reaction
11. From the list given below, select the character which can be acquired but not inherited
- (a) colour of eye
 - (b) colour of skin
 - (c) size of body
 - (d) nature of hair

12.

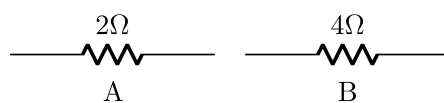

- Two resistors are shown in the above figure when it connected to a battery will have
- (a) same current flowing through them when connected in parallel
 - (b) same current flowing through them when connected in series
 - (c) same potential difference across them when connected in series
 - (d) different potential difference across them when connected in parallel
13. For a current in a long straight solenoid N and S -poles are created at the two ends. Among the following statements, the incorrect statement is
- (a) The field lines inside the solenoid are in the form of straight lines which indicates that the magnetic field is the same at all points inside the solenoid.
 - (b) The strong magnetic field produced inside the solenoid can be used to magnetise a piece of magnetic material like soft iron, when placed inside the coil.
 - (c) The pattern of the magnetic field associated with the solenoid is different from the pattern of the magnetic field around a bar magnet.
 - (d) The N and S -poles exchange position when the direction of current through the solenoid is reversed.
14. The respiratory route of air in the respiratory tract of human is :



Continue on next page.....

Click the Following Button to See the Free MS/Solutions

SOLUTIONS

- (a) nostrils → pharynx → larynx → trachea → alveoli.
- (b) alveoli → pharynx → larynx → trachea → nostrils.
- (c) alveoli → larynx → trachea → pharynx → nostrils.
- (d) nostrils → trachea → pharynx → larynx → alveoli.

15. Since the environment is not under the control of the individual organism, the outside source of energy is quite:
- (a) Varied
 - (b) Same
 - (c) Differ from case to case
 - (d) Under the control of organism
16. Which of the following statements is correct about receptors ?
- (a) Gustatory receptors detect taste while olfactory receptors detect smell.
 - (b) Both gustatory and olfactory receptors detect smell.
 - (c) Auditory receptors detect smell and olfactory receptors detect taste.
 - (d) Olfactory receptors detect taste and gustatory receptors detect smell.

Question no. 17 to 20 are Assertion-Reasoning based questions.

17. **Assertion :** A chemical equation should be balanced.
Reason : Number of atoms of each element should be same on reactants as well as products side.
- (a) Both Assertion and Reason are True and Reason is the correct explanation of the Assertion.
 - (b) Both Assertion and Reason are True but Reason is not the Correct explanation of the Assertion.
 - (c) Assertion is True but the Reason is False.
 - (d) Both Assertion and Reason are False.
18. **Assertion :** DNA finger printing is a method in which polymerase chain reaction followed by DNA probe is used.
Reason : A DNA finger print is inherited and therefore, resembles that of parents.
- (a) Both assertion (A) and reason (R) are true and reason (R) is the correct explanation of assertion (A).
 - (b) Both assertion (A) and reason (R) are true but reason (R) is not the correct explanation of assertion (A).
 - (c) Assertion (A) is true but reason (R) is false.
 - (d) Assertion (A) is false but reason (R) is true.
19. **Assertion :** Carbon monoxide is injurious to the health of the individual.
Reason : Carbon monoxide has very strong affinity for the blood.
- (a) Both Assertion and Reason are true and Reason is the correct explanation of Assertion.
 - (b) Both Assertion and Reason are true but Reason is not the correct explanation of Assertion.
 - (c) Assertion is true but Reason is false.
 - (d) Both Assertion and Reason are false.
20. **Assertion :** The magnetic field is stronger at a point which is nearer to the conductor and goes on decreasing on moving away from the conductor.
Reason : The magnetic field B produced by a straight current carrying wire is inversely proportional to the distance from the wire.
- (a) Both assertion (A) and reason (R) are true and reason (R) is the correct explanation of assertion (A).
 - (b) Both assertion (A) and reason (R) are true but reason (R) is not the correct explanation of assertion (A).
 - (c) Assertion (A) is true but reason (R) is false.
 - (d) Assertion (A) is false but reason (R) is true.

Click the Following Button to See the Free MS/Solutions

SOLUTIONS

SECTION-B

Question no. 21 to 26 are very short answer questions.

21. A metal A , which is used in thermit process, when heated with oxygen gives an oxide B , which is amphoteric in nature. Identify A and B . Write down the reactions of oxide B with HCl and NaOH .

or

In one method of rust prevention, the iron is not coated with anything. Name the method and define it.

22. Why does herbivores have longer small intestine than carnivores ?
23. Do the fresh water animals reabsorb water through their excretory system like marine animal ? Justify your answer.
24. What is translocation ? Why is it essential for plants?
25. What would the sky look if the earth had no atmosphere ? Why ?
- or
- How do we see colours ?
26. What is ten percent law ? Explain by an example.

SECTION-C

Question no. 27 to 33 are short answer questions.

27. Lead nitrate solution is added to a test tube containing potassium iodide solution.
- Write the name and colour of the compound precipitated.
 - Write the balanced chemical equation for the reaction involved.
 - Name the type of this reaction justifying your answer.
28. Give the reaction involved during extraction of zinc from its ore by
- roasting of zinc ore.
 - calcination of zinc ore.
 - reduction of zinc oxide.
29. (a) Why is vegetative propagation practised for growing some types of plants ?
- Name the different parts of a flower that has germ cells.
 - List any two agents of pollination.
- or
- List three distinguishing features between sexual and asexual types of reproduction.
 - Explain why variations are observed in the offsprings of sexually reproducing organisms ?

Click the Following Button to See the Free MS/Solutions

SOLUTIONS

30. The image formed by a spherical mirror is real, inverted and is of magnification -2 . If the image is at a distance of 30 cm from the mirror, where is the object placed? Find the focal length of the mirror. List two characteristics of the image formed if the object is moved 10 cm towards the mirror.
31. (i) Define optical centre of a spherical lens.
 (ii) A divergent lens has a focal length of 20 cm. At what distance should an object of height 4 cm from the optical centre of the lens be placed so that its image is formed 10 cm away from the lens. Find the size of the image also.
 (iii) Draw a ray diagram to show the formation of image in above situation.
32. The diagram below shows a coil connected to a center zero galvanometer G . The galvanometer shows a deflection to the right when the N pole of a powerful magnet is moved to the right as shown.
- (i) Explain why the deflection occurs in the galvanometer.
 (ii) Does the direction of current in the coil appear clockwise or anti-clockwise when viewed from end A ?
 (iii) State the observation in G when the coil is moved away from N .
 (iv) State the observation in G when both coil and the magnet, are moved to the right at the same speed.

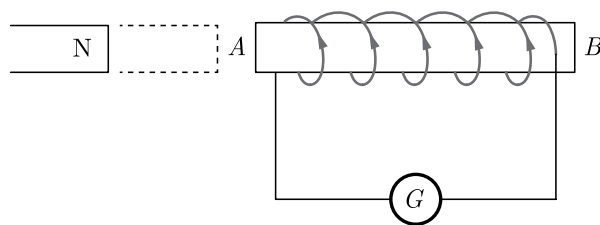

or

- (a) Draw the magnetic field lines of the field produced due to a current carrying circular loop.
 (b) State the law used to find the direction of magnetic field around a straight current carrying conductor.
33. What do you mean by focal chain? Give the characteristics of food chain.

SECTION-D

Question no. 34 to 36 are Long answer questions.

34. (I) Complete the following reactions :
- (a) $\text{C}_2\text{H}_5\text{OH} + \text{CH}_3\text{COOH} \xrightarrow{\text{Conc. H}_2\text{SO}_4} + \text{H}_2\text{O}$
 (b) $\text{CH}_4 + \text{Cl}_2 \xrightarrow{\text{Sunlight}} \dots + \text{HCl}$
 (c) $\text{CH}_3\text{CH}_2\text{OH} \xrightarrow[\text{H}_2\text{SO}_4]{\text{Hot conc.}} \dots + \text{H}_2\text{O}$
- (II) State two properties of carbon which lead to huge number of carbon compounds we see around us.

or

Answer the following questions :

- (a) Describe a chemical test to distinguish between ethanol and ethanoic acid.
 (b) Give reason for the following :
 (i) Ethanol is used in the preparation of tincture iodine.
 (ii) Ethanoic acid is used in the preservation of pickles.

Click the Following Button to See the Free MS/Solutions

SOLUTIONS

35. (a) Suggest any two categories of contraceptive methods to control the size of human population which is essential for the prosperity of a country. Also explain about each method briefly.
 (b) Name two bacterial and two viral infections each that can get sexually transmitted.
 (c) List two advantages of using condom during sexual act.

or

- (i) Describe the role of prostate gland, seminal vesicle and testes in the human male reproductive system.
 (ii) How is the surgical removal of unwanted pregnancies misused?
 (iii) Explain the role of oral contraceptive pills in preventing conception.
36. Find out the following in the electric circuit given in figure :

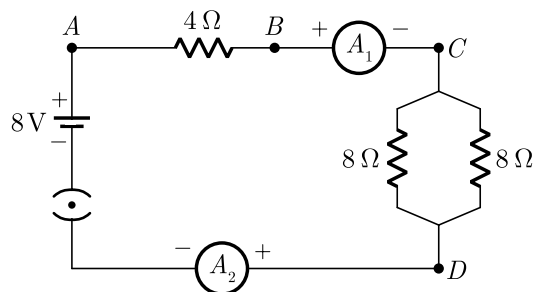

- (a) Effective resistance of two 8 Ω resistors in the combination.
 (b) Current flowing through 4 Ω resistor.
 (c) Potential difference across 4 Ω resistance.
 (d) Power dissipated in 4 Ω resistor.
 (e) Difference in ammeter readings, if any.

SECTION-E

Question no. 37 to 39 are case-based/data-based questions with 2 to 3 short sub-parts. Internal choice is provided in one of these sub-parts.

37. The arrangement of metals in a vertical column in the decreasing order of their re-activities is called the reactivity series or activity series of metals. The most reactive metal is at the top position of the reactivity series. The least reactive metal is at the bottom of the reactivity series.

Hydrogen, though a non-metal, has been included in the activity series of metals only for comparison. Apart from it, the hydrogen atom also has tendency to lose its valence electron and form cation like the behaviour shown by metals. Thus,

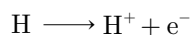

- (i) An element 'X' after reacting with acids liberate hydrogen gas and can displace lead and tin from their salt solution. Write down the Name of X metal.
 (ii) Which metal can be displaced by copper from its salt solution ?

or

- (ii) Write down the name of most reactive metal and which metal does not liberate hydrogen gas after reacting with acid ?

38. The human brain is the command centre for the human nervous system. It receives signals from the body's sensory organs and outputs information to the muscles. The human brain has the same basic structure as other mammal brains but is larger in relation to body size than the brains of many other mammals, such as dolphins, whales and elephants.

Continue on next page.....

Click the Following Button to See the Free MS/Solutions

SOLUTIONS

The human brain weighs about 3 lbs. (1.4 kilograms) and makes up about 2% of a humans body weight. On average, male brains are about 10% larger than female brains, according to North-western Medicine in Illinois. The average male has a brain volume of nearly 78 cubic inches (1,274 cubic centimetres), while the average female brain has a volume of 69 cubic inches (1,131 cubic cm). The cerebrum, which is the main part of the brain located in the front area of the skull, makes up 85% of the brain’s weight.



- (i) Name the given figure and identify the labelled part Q and R.
 - (ii) Which region is responding for pain and conscious association ?
 - (iii) Give two functions of the part ‘P’.
- or**
- (iv) Facial muscular activities and auditory reception are respectively controlled by

39. Is there a relationship between the radius of curvature R , and focal length f , of a spherical mirror ? For spherical mirrors of small apertures, the radius of curvature is found to be equal to twice the focal length. We put this as $R = 2f$. This implies that the principal focus of a spherical mirror lies midway between the pole and centre of curvature.



- (i) Write relation between radius of curvature and focal length.
 - (ii) For which type of mirrors above relation is verified?
 - (iii) What should be size of the aperture ?
- or**
- (iv) Where is the principle focus of a spherical mirror lies?

□□□□□□

DOWNLOAD INDIA’S BEST STUDY MOBILE APP

- 30 Sample Paper with Solutions
- Chapterwise Question Bank of All Subject
- Previous 15 Years Solved Papers
- NCERT Solutions
- Case Study Questions with full Solutions
- **Word File of Material for Teachers**

Search by **NODIA** on Play Store to Download App
 Add 89056 29969 in Your Class Whatsapp Group to Get Link

Click the Following Button to See the Free MS/Solutions

SOLUTIONS

Sample Paper 10

Class X 2023-24

Science (086)

Time: 3 Hours

Max. Marks: 80

General Instructions:

1. This question paper consists of 39 questions in 5 sections.
 2. All questions are compulsory. However, an internal choice is provided in some questions. A student is expected to attempt only one of these questions.
 3. Section A consists of 20 Objective Type questions carrying 1 mark each.
 4. Section B consists of 6 Very Short questions carrying 02 marks each. Answers to these questions should be in the range of 30 to 50 words.
 5. Section C consists of 7 Short Answer type questions carrying 03 marks each. Answers to these questions should be in the range of 50 to 80 words.
 6. Section D consists of 3 Long Answer type questions carrying 05 marks each. Answer to these questions should be in the range of 80 to 120 words.
 7. Section E consists of 3 source-based/case-based units of assessment of 04 marks each with sub-parts.
-

SECTION-A

Select and write one most appropriate option out of the four options given for each of the questions 1 – 20.

1. Observe the diagram of an activity given below. What does it help to conclude, when the person exhales into the test-tube?

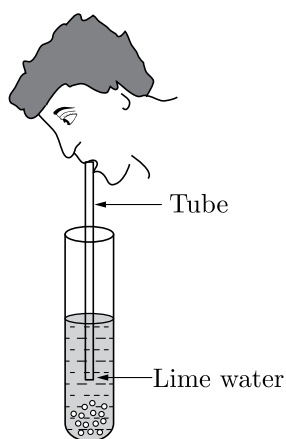

- (a) Fermentation occurs in the presence of oxygen
- (b) Percentage of carbon dioxide is more in inhaled air.
- (c) Fermentation occurs in the presence of carbon dioxide.
- (d) Percentage of carbon dioxide is more in the exhaled air.

Continue on next page.....

Click the Following Button to See the Free MS/Solutions

SOLUTIONS

2. Galvanisation is a method of protecting iron from rusting by coating with a thin layer of:
- aluminium
 - gallium
 - silver
 - zinc
3. The current flowing through a wire of resistance 2Ω varies with time as shown in figure below. The amount of heat produced (in J) in 3 s would be:

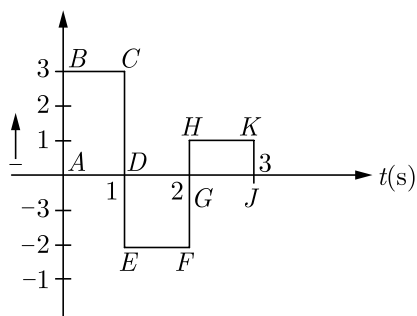

- 18 J
 - 2 J
 - 10 J
 - 28 J
4. The magnetic field lines of solenoid are similar to the magnetic field lines of bar magnet. Which image correctly shows the solenoid as a bar magnet?

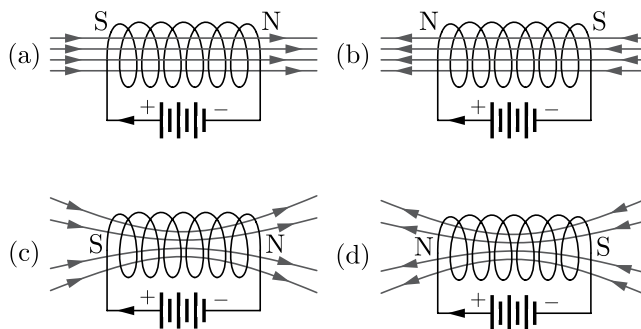

Continue on next page.....

Click the Following Button to See the Free MS/Solutions

SOLUTIONS

5.

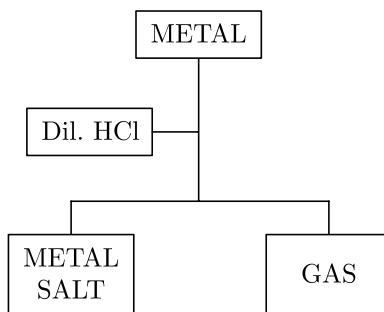

Which of the following two combinations are correct?

	Metal	Gas Evolved
(i)	Copper	Yes
(ii)	Iron	Yes
(iii)	Magnesium	No
(iv)	Zinc	Yes

- (a) i and iii
 (b) i and iv
 (c) ii and iii
 (d) ii and iv
6. Equal volumes of hydrochloric acid and sodium hydroxide solutions of same concentration are mixed and the pH of the resulting solution is checked with a pH paper. What would be the colour obtained?
 (a) Red
 (b) Blue
 (c) Orange
 (d) Yellowish green
7. The direction of magnetic field around a straight conductor carrying current can be determined by:
 (a) Fleming's right hand rule
 (b) Right hand thumb rule
 (c) Lenz's law
 (d) Fleming's left hand rule
8. Ankit observed that the stain of curry on a white shirt becomes reddish-brown when soap is scrubbed on it, but it turns yellow again when the shirt is washed with plenty of water. What might be the reason for his observation?
 (i) Soap is acidic in nature.
 (ii) Soap is basic in nature.
 (iii) Turmeric is a natural indicator which gives reddish tinge in bases.
 (iv) Turmeric is a natural indicator which gives reddish tinge in acids.
 (a) (ii) and (iii)
 (b) (i) and (ii)
 (c) (ii) and (iv)
 (d) (i) and (iv)

Continue on next page.....

Click the Following Button to See the Free MS/Solutions

SOLUTIONS

9. Which of the following hydrocarbons represent the isomer of Butene?

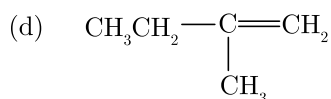
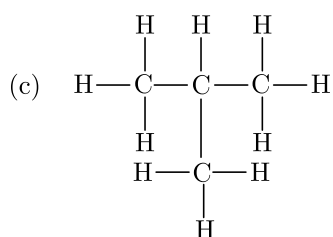
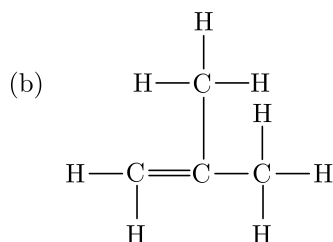
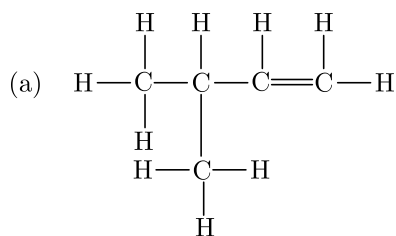

10. Which option correctly lists the changes that occur in females during puberty?

- (a) reproductive organs enlarge, size of the breasts increases, thick hairs grow on the body
- (b) thick hairs grow on face, cracking of voice, enlargement of reproductive organ
- (c) size of the breasts increases, beginning of menstruation, thick hairs grow on the body
- (d) thin hairs growth occurs on the body, size of the breasts increases, pitch of the voice increases

11. What is the correct direction of flow of electrical impulses?

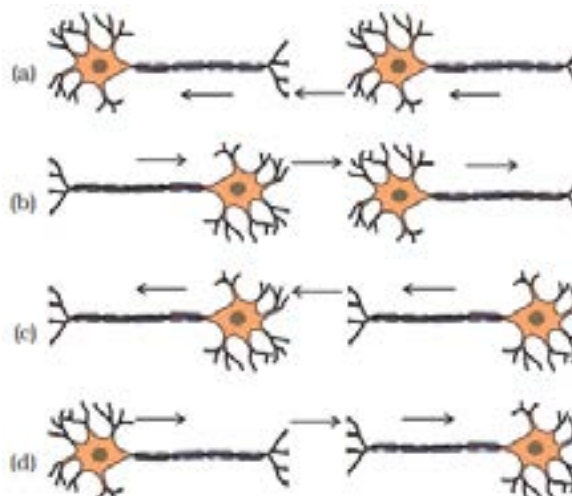

Click the Following Button to See the Free MS/Solutions

SOLUTIONS

12. Two bulbs have the following ratings :

1. 40 W, 220 V.

2. 20 W, 100 V.

The ratio of their resistance is :

(a) 2 : 1

(b) 1 : 2

(c) 1 : 3

(d) 1 : 1

13. Which of the following statements are correct in reference to the role of A (shown in the given diagram) during a breathing cycle in human beings?



(i) It helps to decrease the residual volume of air in lungs.

(ii) It flattens as we inhale.

(iii) It gets raised as we inhale.

(iv) It helps the chest cavity to become larger.

(a) (iii) and (iv)

(b) (ii) and (iv)

(c) (i), (ii) and (iv)

(d) (i) and (ii)

14. Following observations are observed when calcium oxide reacts vigorously with water.

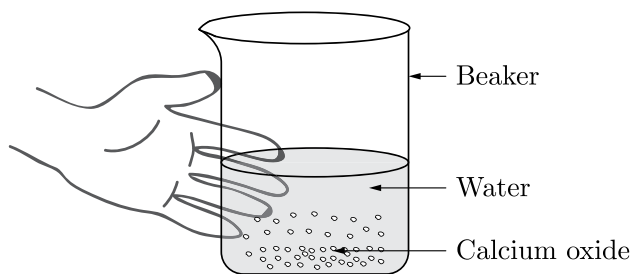

Continue on next page.....

Click the Following Button to See the Free MS/Solutions

SOLUTIONS

Identify the incorrect observations.

- (i) It is an endothermic reaction.
 - (ii) Slaked lime is produced.
 - (iii) Quick lime is produced.
 - (iv) It is an exothermic reaction.
 - (v) It is a combination reaction.
- (a) (iii) and (iv)
 - (b) (i) and (ii)
 - (c) (ii), (iv) and (v)
 - (d) (i) and (iii)

15. In which of the following setups would the bulb glow?

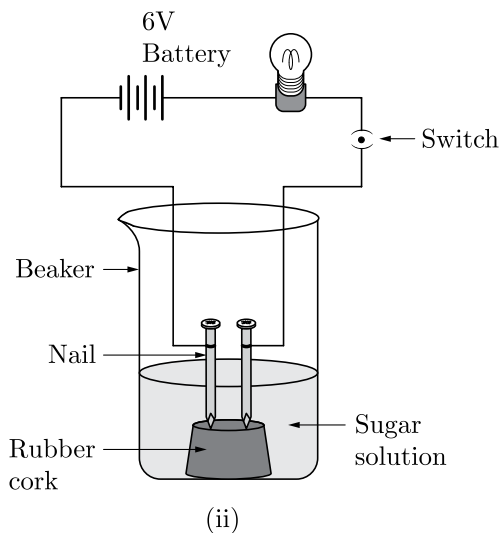
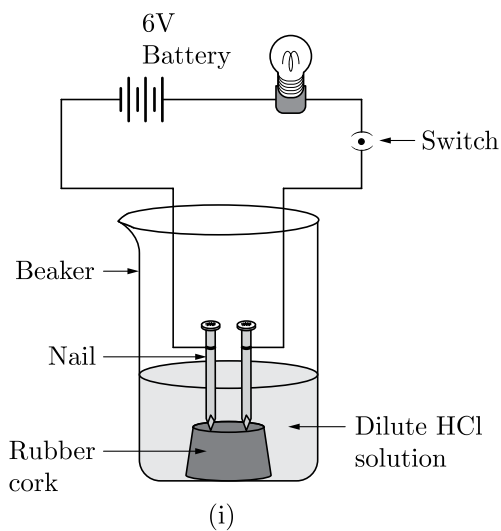

Continue on next page.....

Click the Following Button to See the Free MS/Solutions

SOLUTIONS

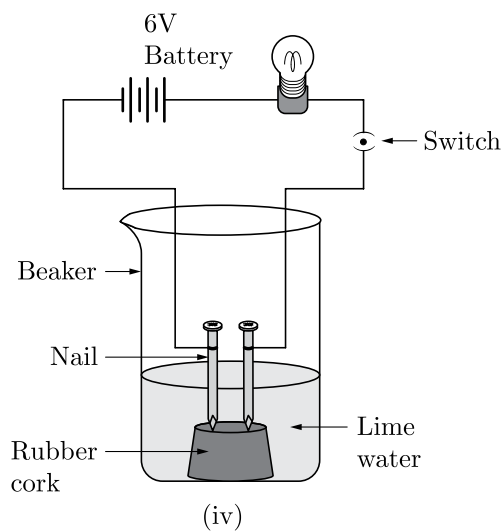
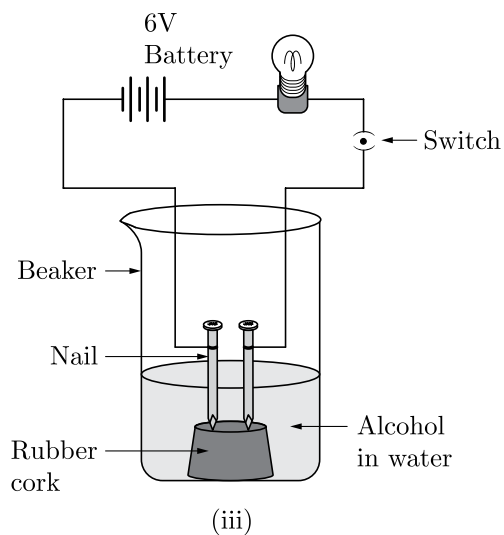

- (a) (i) and (iv)
- (b) (i) and (ii)
- (c) (i), (ii) and (iv)
- (d) (ii), (iii) and (iv)

16. If two parents have the genotypes $AA \times aa$, the probability of having an aa genotype in the F_1 generation is:
- (a) 50 per cent
 - (b) 25 per cent
 - (c) None of these
 - (d) 75 per cent

Click the Following Button to See the Free MS/Solutions

SOLUTIONS

Question no. 17 to 20 are Assertion-Reasoning based questions.

- 17. Assertion (A):** Accumulation of variation in a species increases the chances of its survival in changing environment.
Reason (R): Accumulation of heat resistance in some bacteria ensure their survival even when temperature in environment rises too much.
- (a) Both Assertion (A) and Reason (R) are true and Reason (R) is the correct explanation of Assertion (A).
(b) Both Assertion (A) and Reason (R) are true but Reason (R) is not the correct explanation of Assertion (A).
(c) Assertion (A) is true but Reason (R) is false.
(d) Assertion (A) is false but Reason (R) is true.
- 18. Assertion (A):** A solenoid tends to expand, when current passes through it.
Reason (R): Two straight parallel metallic wires carrying current in same direction repel each other.
- (a) Both Assertion (A) and Reason (R) are true and Reason (R) is the correct explanation of Assertion (A).
(b) Both Assertion (A) and Reason (R) are true but Reason (R) is not the correct explanation of Assertion (A).
(c) Assertion (A) is true but Reason (R) is false.
(d) Assertion (A) is false but Reason (R) is true.
- 19. Assertion (A):** It is necessary to separate oxygenated and de-oxygenated blood in mammals and birds.
Reason (R): Mammals and birds are warm blooded animals and they depend on environment for their body temperature regulation.
- (a) Both Assertion (A) and Reason (R) are true and Reason (R) is the correct explanation of Assertion (A).
(b) Both Assertion (A) and Reason (R) are true but Reason (R) is not the correct explanation of Assertion (A).
(c) Assertion (A) is true but Reason (R) is false.
(d) Assertion (A) is false but Reason (R) is true.
- 20. Assertion (A):** Decomposition of vegetable matter into compost is an endothermic reaction.
Reason (R): Decomposition reaction involves breakdown of a single reactant into simpler products.
- (a) Both Assertion (A) and Reason (R) are true and Reason (R) is the correct explanation of Assertion (A).
(b) Both Assertion (A) and Reason (R) are true but Reason (R) is not the correct explanation of Assertion (A).
(c) Assertion (A) is true but Reason (R) is false.
(d) Assertion (A) is false but Reason (R) is true.

SECTION-B

Question no. 21 to 26 are very short answer questions.

- 21.** How can change of size of eyeball be one of the reason for:
- (i) Myopia
(ii) Hypermetropia
- Compare the size of eyeball with that of a normal eye in each case. How does this change of size affect the position of image in each case?

or

State the cause of dispersion of white light by a glass prism. Draw a labelled diagram to illustrate the recombination of the spectrum of white light. Why is it essential that the two prisms used for the purpose should be identical and placed in an inverted position with respect to each other?

Continue on next page.....

Click the Following Button to See the Free MS/Solutions

SOLUTIONS

22. How is O_2 and CO_2 transported in human beings?
23. DDT was sprayed in a lake to regulate breeding of mosquitoes. How would it affect the trophic levels in the following food chain associated with a lake? Justify your answer.

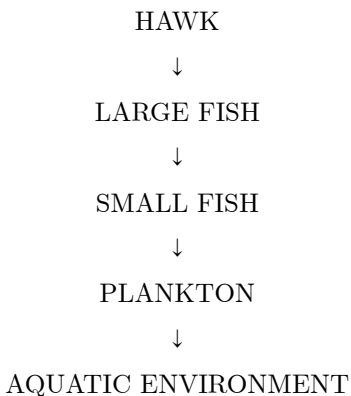

24. List two different functions performed by pancreas in our body.
25. A green salt on heating decomposes to produce a colourless suffocating gas and leaves behind a reddish brown residue. Name the salt and write the decomposition reaction.

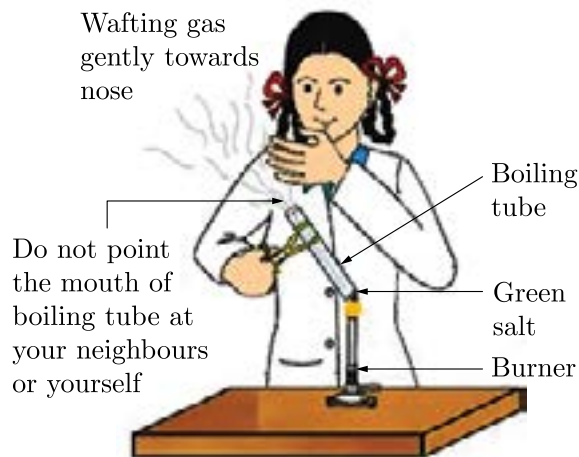

or

Give suitable reason for the following statements:

- (i) We feel burning sensation in the stomach when we overeat.
- (ii) The crystals of washing soda change to white powder on exposure to air.

Continue on next page.....

Click the Following Button to See the Free MS/Solutions

SOLUTIONS

26. Label the parts of a neuron in the given figure:

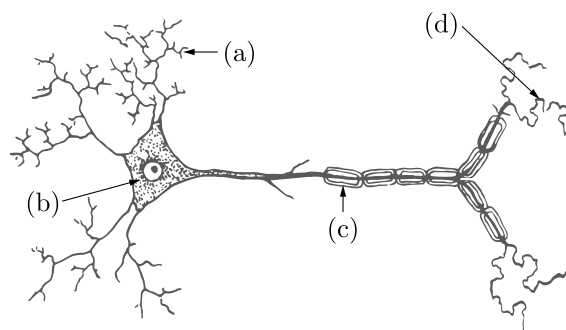

SECTION-C

Question no. 27 to 33 are short answer questions.

27. (i) Draw ray diagram to show the principal focus of
 (a) a concave mirror, and
 (b) a convex mirror.
 (ii) In the following diagram, MM is a concave mirror and AB is an object. Draw on your answer sheet a ray diagram to show the formation of image of this object.

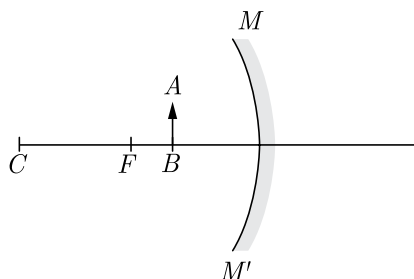

28. (i) Write the essential condition for the following reaction to take place:
 $2\text{AgBr} \longrightarrow 2\text{Ag} + \text{Br}_2$
 Write one application of this reaction.
 (ii) Complete the following chemical equation of a chemical reaction:
 $2\text{FeSO}_4 \xrightarrow{\text{Heat}} \text{Fe}_2\text{O}_3 + \dots + \dots$
 (iii) What happens when water is added to quick lime? Write chemical equation.

Continue on next page.....

Click the Following Button to See the Free MS/Solutions

SOLUTIONS

29. (i) Name the poles P, Q, R and S of the magnets in the following figures a and b.

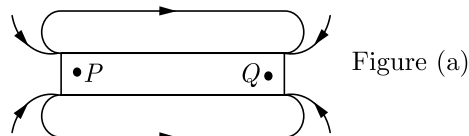

Figure (a)

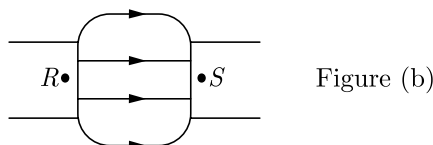

Figure (b)

- (ii) State the inference drawn about the direction of the magnetic field lines on the basis of these diagrams.

or

State right-hand thumb rule to determine the direction of magnetic field around a current carrying conductor. Apply this rule to find the direction of magnetic field inside and outside a circular loop of wire lying in the plane of a table and current is flowing through it clockwise.

30. The table below shows the colour of universal indicator paper (UI paper) at different pH values.

Colour	Orange		Green		Blue		Purple							
pH	1	2	3	4	5	6	7	8	9	10	11	12	13	14
Colour	Red		Yellow		Dark green		Dark blue							
	Acid		Neutral				Alkali							

- (i) UI paper turns purple in oven cleaner solution. What is the pH of oven cleaner solution?
 (ii) Suggest the substance in oven cleaner solution that turns UI paper purple.
 (iii) UI paper turns yellowish-green in milk. What is the pH of milk?
 (iv) The milk was left outside for five days. When the milk was re-tested with UI paper, the paper turned orange. What has happened to the milk?

31. How can we help in reducing the problem of waste disposal? Suggest any three methods.

32. Describe the structure and function of the basic filtering unit of kidney.

or

How does nutrition take place in Amoeba? How is it different in Paramecium?

33. A student wants to project the image of a candle flame on a screen 80 cm in front of a mirror by keeping the candle flame at a distance of 20 cm from its pole.

- (i) Which type of mirror should the student use?
 (ii) Find the magnification of the image produced.
 (iii) Find the distance between the object and its image.
 (iv) Draw a ray diagram to show the image formation in this case and mark the distance between the object and its image.

Continue on next page.....

Click the Following Button to See the Free MS/Solutions

SOLUTIONS

SECTION-D

Question no. 34 to 36 are Long answer questions.

34. Based on the given diagram, answer the questions given below:

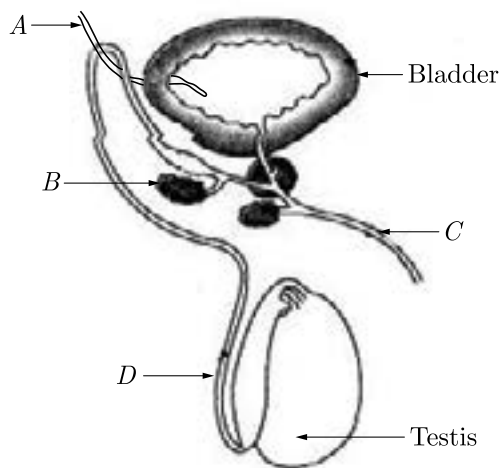

- Label the parts A, B, C and D.
- Name the hormones secreted by testis and mention its role.
- State the functions of B and C in the process of reproduction.

or

- Draw a diagram showing germination of pollen on stigma of a flower and mark on it the following organs/parts:
 - Pollen grain
 - Pollen tube
 - Stigma
 - Female germ-cell
- State the significance of pollen tube.
- Name the parts of flower that develop after fertilisation into:
 - Seed
 - Fruit

35. (i) How will you infer with the help of an experiment that the same current flows through every part of the circuit containing three resistors R_1 , R_2 and R_3 in series connected to a battery of V volts?
- (ii) Study the following circuit and find out:
- Current in 12Ω resistor.
 - Difference in the readings of A_1 and A_2 , if any.

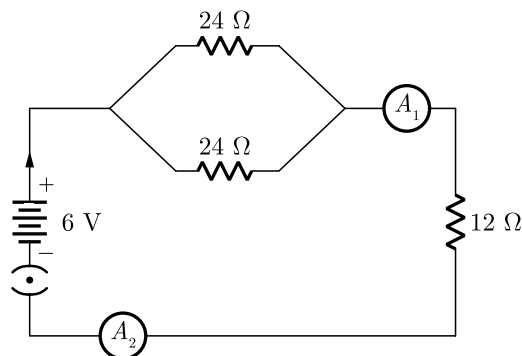

Click the Following Button to See the Free MS/Solutions

SOLUTIONS

36. Soaps and detergents are both types of salts. State the difference between the two. Write the mechanism of the cleansing action of soaps. Why do soaps not form lather (foam) with hard water? Mention any two problems that arise due to the use of detergents instead of soaps.

or

A compound A ($C_2H_4O_2$) reacts with Na metal to form a compound 'B' and evolves a gas which burns with a pop sound. Compound 'A' on treatment with an alcohol 'C' in presence of an acid forms a sweet smelling compound 'D' ($C_4H_8O_2$). On addition of NaOH to 'D' gives back B and C. Identify A, B, C and D. Write the reactions involved.

SECTION-E

Question no. 37 to 39 are case-based/data-based questions with 2 to 3 short sub-parts. Internal choice is provided in one of these sub-parts.

37. The modes by which various organisms reproduce depend on the body design of the organisms. In asexual reproduction, a single individual parent produces offsprings without the involvement of gametes. This method is a common means of increasing the offsprings rapidly under favourable conditions. Asexual reproduction occurs mostly in unicellular organisms, some plants and certain simple multicellular animals.

- State the name of the organism in which binary fission takes place in a definite orientation. Also name the disease caused by this organism.
- Leaves of 'Bryophyllum' when they fall on the soil develop into new plants whereas a banana leaf will not be able to do so. Why?
- Explain the process of budding in Hydra.

or

- What happens when:
 - a Spirogyra filament matures and attains a considerable length and
 - a sporangia in Rhizopus bursts on maturation?

38. Electrolysis of water is a popular method used for different applications in various industries. The electrolysis of water is mainly carried out to yield pure hydrogen and oxygen gases. It involves passing an electric current through the water which results in decomposition of water into hydrogen and oxygen.

Pure water is a poor conductor of electricity. Sulphuric acid is added to the water so that the conductance of water increases which makes the reaction faster. The setup for electrolysis of water is given below:

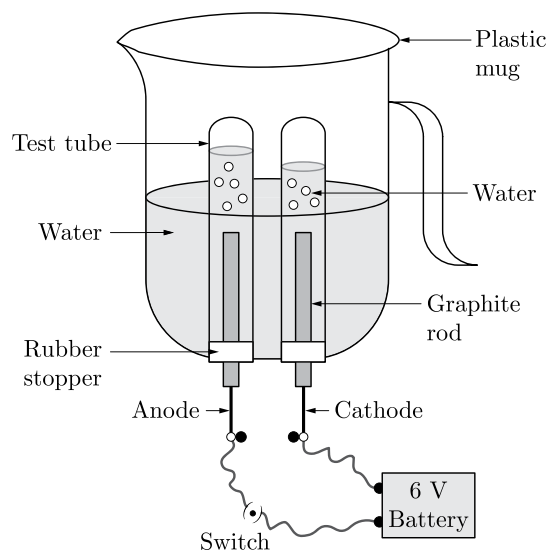

Continue on next page.....

Click the Following Button to See the Free MS/Solutions

SOLUTIONS

The number of hydrogen molecules produced in electrolysis is twice the number of oxygen molecules. Also, hydrogen is double in volume than oxygen.

- (i) Name the gases evolved at cathode and anode respectively. Why is volume of one gas collected at one electrode is double of anode?
 (ii) How will you test the gas evolved at cathode and at anode?

or

- (iv) Write the chemical equation for electrolysis of water.
 Why are few drops of H_2SO_4 added to pure water?

39. Aditya and his friend Manoj placed a candle flame in front of a convex lens at various distances from it and obtained the image of the candle flame on a white screen.

He noted down the position of the candle, screen and the lens as under

Position of candle = 20 cm

Position of convex lens = 50 cm

Position of the screen = 80 cm

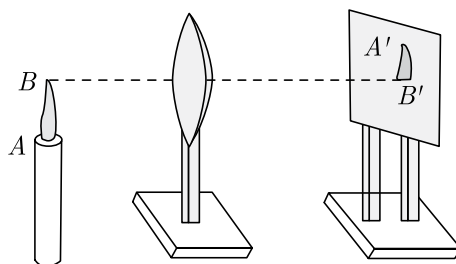

- (i) What is the position of the image formed from the convex Lens?
 (ii) What is the focal length of the convex lens?

or

Where will the image be formed, if he shifts the candle towards the lens at a position of 35 cm?

- (iii) What is the nature of the image formed if Aditya shifts the candle towards the lens to 36m?

□□□□□□

DOWNLOAD INDIA'S BEST STUDY MOBILE APP

- 30 Sample Paper with Solutions
- Chapterwise Question Bank of All Subject
- Previous 15 Years Solved Papers
- NCERT Solutions
- Case Study Questions with full Solutions
- **Word File of Material for Teachers**

Search by **NODIA** on Play Store to Download App

Add 89056 29969 in Your Class Whatsapp Group to Get Link

Click the Following Button to See the Free MS/Solutions

SOLUTIONS

Sample Paper 11

Class X 2023-24

Science (086)

Time: 3 Hours

Max. Marks: 80

General Instructions:

1. This question paper consists of 39 questions in 5 sections.
 2. All questions are compulsory. However, an internal choice is provided in some questions. A student is expected to attempt only one of these questions.
 3. Section A consists of 20 Objective Type questions carrying 1 mark each.
 4. Section B consists of 6 Very Short questions carrying 02 marks each. Answers to these questions should be in the range of 30 to 50 words.
 5. Section C consists of 7 Short Answer type questions carrying 03 marks each. Answers to these questions should be in the range of 50 to 80 words.
 6. Section D consists of 3 Long Answer type questions carrying 05 marks each. Answer to these questions should be in the range of 80 to 120 words.
 7. Section E consists of 3 source-based/case-based units of assessment of 04 marks each with sub-parts.
-

SECTION-A

Select and write one most appropriate option out of the four options given for each of the questions 1 – 20.

1.

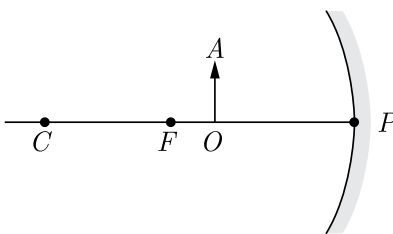

For the diagram shown, according to the new Cartesian sign convention the magnification of the image formed will have the following specifications:

- (a) Sign — Positive, Value — More than 1
- (b) Sign — Positive, Value — Less than 1
- (c) Sign — Negative, Value — More than 1
- (d) Sign — Negative, Value — Less than 1

Continue on next page.....

Click the Following Button to See the Free MS/Solutions

SOLUTIONS

2. The table shows the changes that occur in girls during puberty.

(i)	Increases in the size of the breasts.
(ii)	Beginning of menstruation.
(iii)	Darkening of skin around the nipples.

What is the likely significance of these changes?

- (a) Sexual maturation
 (b) Aging of the body
 (c) Abnormal division of the cells
 (d) Production of germ cells
3. Rahul is a skilled painter. He mixed a white coloured powder, compound X with water. The compound X reacted vigorously with water to produce a compound Y and a large amount of heat. Then, Rahul used the compound Y for white washing the walls.

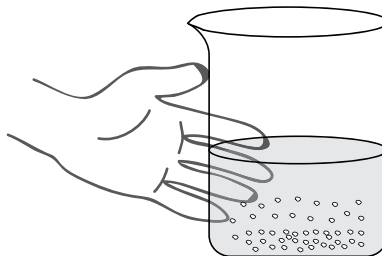

Name the compound Y that Rahul got after mixing X with water.

- (a) Calcium oxide
 (b) Calcium
 (c) Calcium hydroxide
 (d) Calcium carbonate
4. In each test tubes A , B , C and D , 2 ml of solution of $\text{Al}_2(\text{SO}_4)_3$ in water was filled. Clean pieces of zinc was placed in test tube A , clean iron nail was put in test tube B , silver (Ag) was placed in test tube C and a clean copper wire was placed in test tube D .

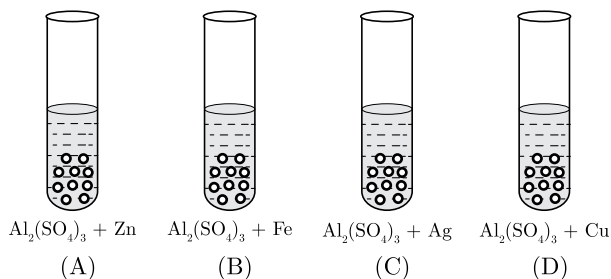

Which of the following option(s) is/are correct about above experiment?

- (a) Copper is more reactive than aluminium.
 (b) Zinc is more reactive than aluminium.
 (c) Zinc, iron, silver and copper are less reactive than aluminium.
 (d) Zinc is more reactive than copper.

Continue on next page.....

Click the Following Button to See the Free MS/Solutions

SOLUTIONS

5. Figure (A), (B), (C) and (D) respectively correspond to

(A)

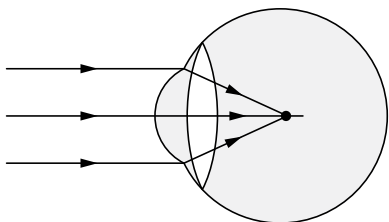

(B)

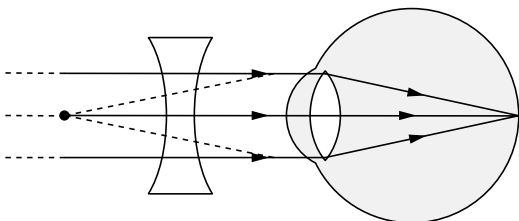

(C)

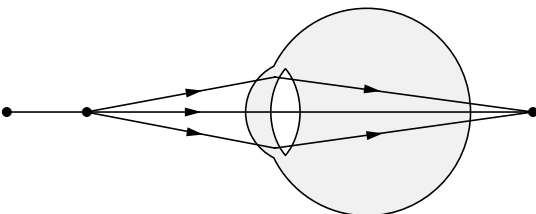

(D)

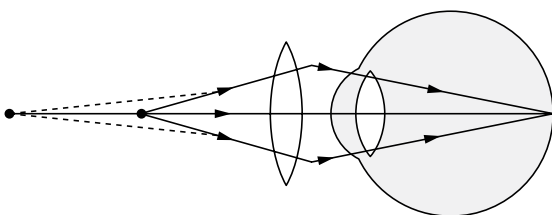

- (a) the short-sighted eye, the correction of long sightedness, the long-sighted eye and the correction of short-sightedness
 (b) the short-sighted eye, the correction of short sightedness, . the long-sighted eye and the correction of long-sightedness
 (c) the long-sighted eye, the correction of short-sightedness, the short-sighted eye and the correction of long-sightedness
 (d) None of the above

6. Which of the following statements about the given reaction are correct?

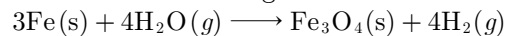

- (i) Iron metal is getting oxidised
 (ii) Water is getting reduced
 (iii) Water is acting as reducing agent
 (iv) Water is acting as oxidising agent
 (a) (iii) and (iv)
 (b) (i),(ii) and (iv)
 (c) (ii) and (iv)
 (d) (i),(ii) and (iii)

Continue on next page.....

Click the Following Button to See the Free MS/Solutions

SOLUTIONS

7. Identify P , Q , R and S in the case of normal human from given flow chart and select the correct option.

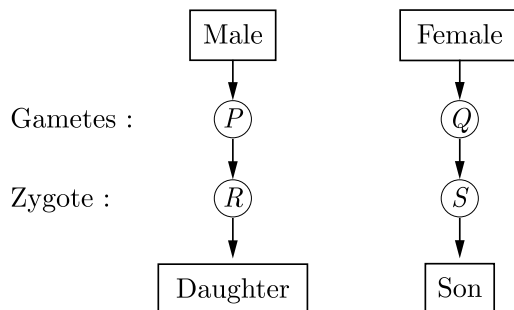

	P	Q	R	S
a.	XX	XY	XY	XX
b.	XY	XX	XX	XY
c.	XX	XY	XX	XY
d.	XY	XX	XY	XX

8. A light bar magnet is suspended near a current-carrying wire as shown below. What will happen to the light bar magnet?

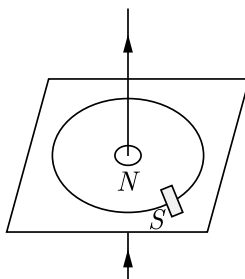

- (a) It will rotate anti-clockwise.
 (b) It will rotate clockwise.
 (c) It will move to the left.
 (d) It will move to the right.
9. An acid (A) with sodium hydrogen carbonate is used in making the cakes fluffy and spongy. It is due to the release of gas (B) in the reaction. Here, (A) and (B) are:
- (a) (A) : Tartaric acid, (B), O_2
 (b) (A) : Oxalic acid, (B), CO_2
 (c) (A) : Tartaric acid, (B). CO_2
 (d) (A) : Succinic acid, (B). H_2

Continue on next page.....

Click the Following Button to See the Free MS/Solutions

SOLUTIONS

10. The diagram shows the arrangement of cells inside the leaf of a green plant. (No cell contents are shown). Which cells normally contain chloroplasts?

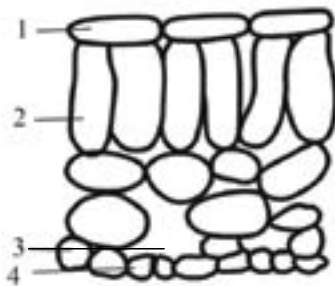

- (a) 1 and 4
 (b) 1 and 2
 (c) 2 and 4
 (d) 2 and 3
11. Nastic movements are non-directional responses to the stimuli. These movements are independent of the direction of the stimulus. On the other hand, growth movements which occur in the direction of the stimulus are called tropic movements.
 Which of the following movements is a nastic movement?
- (a) Closing up of leaves of a sensitive plant on being touched with an object.
 (b) Bending of shoot of a plant in response to light
 (c) Movement of root of a plant towards a source of water.
 (d) Climbing up of a plant on an object by using tendrils.
12. Clean small pieces of magnesium, zinc, aluminium, iron and copper by rubbing them with a piece of sand paper. Take them in separate test tubes. Add about 10 ml of dilute hydrochloric acid to each of them.

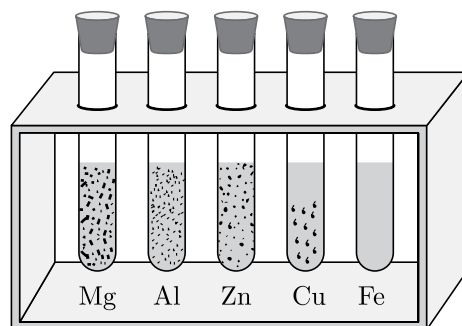

Identify the correct statement(s).

- (i) The rate of evolution of hydrogen gas bubbles is not same in all the test tubes.
 (ii) The rate of formation of bubbles is the fastest in the case of magnesium.
 (iii) The reactivity decreases in the order:
 $Mg > Zn > Al > Fe > Cu$
 (iv) In the case of copper, no bubbles are seen and the temperature also remains unchanged. This shows that copper does not react with dilute HCl.
- (a) (iii) and (iv)
 (b) (ii) and (iv)
 (c) (i), (ii) and (iv)
 (d) Only (iii)

Click the Following Button to See the Free MS/Solutions

SOLUTIONS

13. The table shows the formulae of three organic compounds that belong to the same homologous series.

First member of the homologous series	$\text{CH}_3 - \text{O} - \text{CH}_3$
Second member of the homologous series	$\text{CH}_3\text{CH}_2 - \text{O} - \text{CH}_3$
Third member of the homologous series	$\text{CH}_3\text{CH}_2\text{CH}_2 - \text{O} - \text{CH}_3$

What is the general formula of this series?

- (a) $\text{C}_n\text{H}_{2n+2}\text{O}$
 (b) $\text{C}_n\text{H}_{2n}\text{O}$
 (c) $\text{C}_n\text{H}_{2n+2}\text{OH}$
 (d) $\text{C}_n\text{H}_{2n+2}\text{OH}$

- 14.

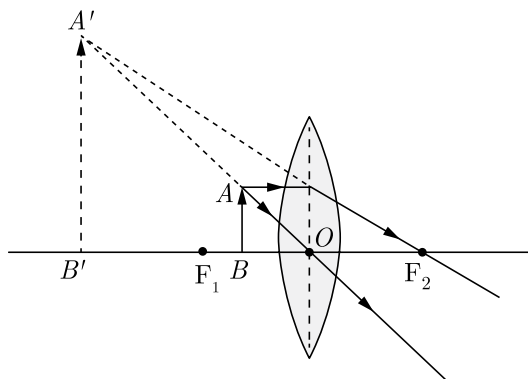

The above lens has a focal length of 10 cm. The object of height 2 mm is placed at a distance of 5 cm from the pole. Find the height of the image.

- (a) 6.67 mm
 (b) 4 cm
 (c) 3.33 mm
 (d) 4 mm
15. Four students (A), (B), (C) and (D) separately measured the pH values of each one of the given samples of distilled water, oxalic acid, dilute hydrochloric acid and a solution of sodium hydroxide using pH papers.

Student	Distilled water	Oxalic acid	Dil. Hydrochloric	Sodium Hydroxide
A.	7	1	1	1
B.	7	3	1	1
C.	7	1	1	13
D.	7	3	1	13

Which one of the following represents correct pH value?

- (a) B
 (b) A
 (c) D
 (d) C

Continue on next page.....

Click the Following Button to See the Free MS/Solutions

SOLUTIONS

16. The diagram shows part of the human respiratory system.

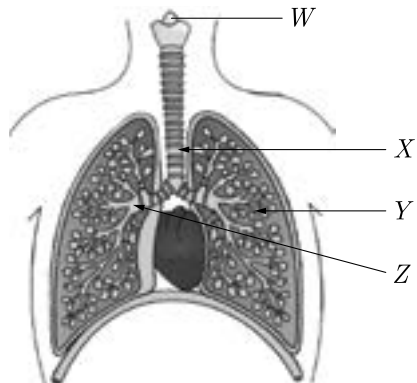

What are *W*, *X*, *Y* and *Z* ?

S.No.	Bronchus	Bronchiole	Larynx	Rings of cartilage
a.	<i>W</i>	<i>X</i>	<i>Z</i>	<i>Y</i>
b.	<i>X</i>	<i>Z</i>	<i>Y</i>	<i>W</i>
c.	<i>Y</i>	<i>W</i>	<i>X</i>	<i>Z</i>
d.	<i>Z</i>	<i>Y</i>	<i>W</i>	<i>X</i>

Question no. 17 to 20 are Assertion-Reasoning based questions.

17. **Assertion (A):** Mendel selected pea plants for this experiments.
Reason (R): Pea plant is self pollinating with short life cycle and bears visible contrasting characters.
 (a) Both Assertion (A) and Reason (R) are true and Reason (R) is the correct explanation of Assertion (A).
 (b) Both Assertion (A) and Reason (R) are true but Reason (R) is not the correct explanation of Assertion (A).
 (c) Assertion (A) is true but Reason (R) is false.
 (d) Assertion (A) is false but Reason (R) is true.
18. **Assertion (A):** When the length of a wire is doubled, then its resistance also gets doubled.
Reason (R): The resistance of a wire is directly proportional to its length.
 (a) Both Assertion (A) and Reason (R) are true and Reason (R) is the correct explanation of Assertion (A).
 (b) Both Assertion (A) and Reason (R) are true but Reason (R) is not the correct explanation of Assertion (A).
 (c) Assertion (A) is true but Reason (R) is false.
 (d) Assertion (A) is false but Reason (R) is true.
19. **Assertion (A):** Transpiration is a necessary evil.
Reason (R): It causes water loss but helps in absorption and upward movement of water and minerals.
 (a) Both Assertion (A) and Reason (R) are true and Reason (R) is the correct explanation of Assertion (A).
 (b) Both Assertion (A) and Reason (R) are true but Reason (R) is not the correct explanation of Assertion (A).
 (c) Assertion (A) is true but Reason (R) is false.
 (d) Assertion (A) is false but Reason (R) is true.

Continue on next page.....

Click the Following Button to See the Free MS/Solutions

SOLUTIONS

20. **Assertion (A):** Following are the structural isomers of butane.

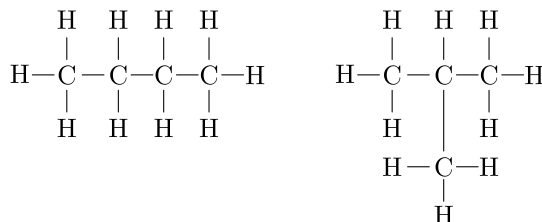

Reason (R): Structural isomers have the same molecular formula, but they differ in their structures.

- (a) Both Assertion (A) and Reason (R) are true and Reason (R) is the correct explanation of Assertion (A).
 (b) Both Assertion (A) and Reason (R) are true but Reason (R) is not the correct explanation of Assertion (A).
 (c) Assertion (A) is true but Reason (R) is false.
 (d) Assertion (A) is false but Reason (R) is true.

SECTION-B

Question no. 21 to 26 are very short answer questions.

21. For the same angle of incidence in media A, B and C, the angles of refraction are 20° , 30° and 40° respectively. In which medium will the velocity of light be maximum? Give reason in support of your answer.

or

Why is the colour of the clear sky blue?

22. (i) What is meant by garbage? List two classes into which garbage is classified.
 (ii) What do we actually mean when we say that the “enzymes are specific in their action”?
23. What are the strategies of plants to get rid of their wastes?
24. What is the advantage of having four chambered heart?
25. A student performs the following four experiments.

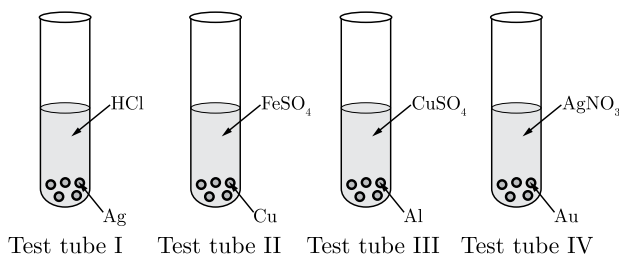

Based on the above experiments:

- (i) In which test tube(s) no reaction occurred? Give reason.
 (ii) Arrange the given metal samples in the increasing order of reactivity.

Continue on next page.....

Click the Following Button to See the Free MS/Solutions

SOLUTIONS

or

The following reaction takes place when aluminium powder is heated with MnO_2 :



- (i) Is aluminium getting reduced?
 (ii) Is MnO_2 getting oxidised?

26. What is feedback mechanism of harmonic regulation? Take the example of insulin to explain this phenomenon.

SECTION-C

Question no. 27 to 33 are short answer questions.

27. Draw a neat and well labelled diagram for electrolytic refining of copper. Write the reactions involved.
28. Write the essential function performed by ozone at the higher levels of the Earth's atmosphere? How is it produced? Name the synthetic chemicals mainly responsible for the drop of amount of ozone in the atmosphere. How can the use of these chemicals be reduced?
29. (i) A circuit contains a battery, a variable resistor and a solenoid. The figure below show the magnetic field pattern produced by the current in the solenoid.

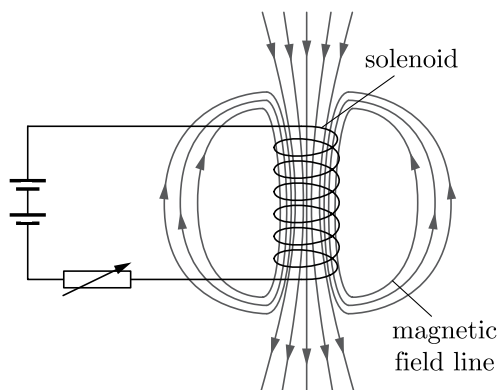

- (a) State how the magnetic field pattern indicates regions where the magnetic field is stronger?
 (b) What happens to the magnetic field when the current in the circuit is reversed?
- (ii) State the direction of magnetic field in the following case.

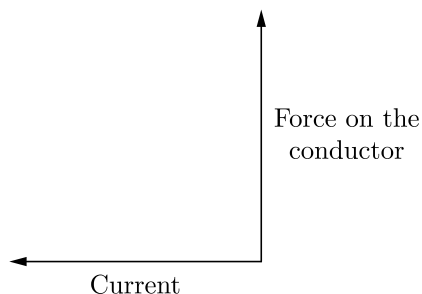

Continue on next page.....

Click the Following Button to See the Free MS/Solutions

SOLUTIONS

or

Name, state and explain with an example the rule used to determine the direction of force experienced by a current carrying conductor placed in a uniform magnetic field.

30. An organic compound X on heating with conc. H_2SO_4 forms a compound Y which on addition of one molecule of hydrogen in the presence of nickel forms a compound Z . One molecule of compound Z on combustion forms two molecules of CO_2 and three molecules of H_2O . Identify giving reasons the compounds X , Y and Z . Write the chemical equations for all the chemical reactions involved.
31. (i) With the help of labelled ray diagram, show the path followed by a narrow beam of monochromatic light when it passes through a glass prism.
 (ii) What would happen if this beam is replaced by a narrow beam of white light?
32. Write one example of each of the following tropic movements:
 (i) Positive phototropism.
 (ii) Negative phototropism.
 (iii) Positive geotropism.
 (iv) Negative geotropism.
 (v) Hydrotropism.
 (vi) Chemotropism.

or

- (i) Name the part of human brain which controls.
 (a) voluntary actions and
 (b) involuntary actions
 (ii) Write the function of peripheral nervous system. Name the components of this system stating their origin.
- 33.

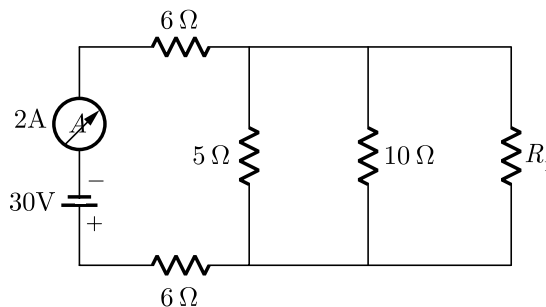

In the above circuit, if the current reading in the ammeter A is $2A$, what would be the value of R_1 ?

SECTION-D

Question no. 34 to 36 are Long answer questions.

34. (i) Define reflex arc. Draw a flowchart showing the sequence of events which occur during sneezing.
 (ii) List four plant hormones. Write one function of each.

Continue on next page.....

Click the Following Button to See the Free MS/Solutions

SOLUTIONS

or

- (i) Identify the endocrine glands *A*, *B*, *C*, *D*, *E* and *F* in the given diagram.
 (ii) List the functions of each part.

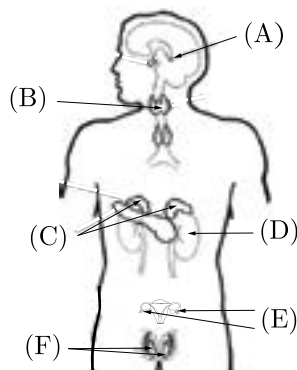

35. (i) Draw magnetic field lines produced around a current carrying straight conductor passing through a cardboard. Name, state and apply the rule to mark the direction of these field lines.
 (ii) How will the strength of the magnetic field change when the point where magnetic field is to be determined is moved away from the straight wire carrying constant current? Justify your answer.
36. A metal nitrate *A* on heating gives yellowish brown coloured metal oxide along with brown gas *B* and a colourless gas *C*. Aqueous solution of *A* on reaction with potassium iodide forms a yellow precipitate of compound *D*. Identify *A*, *B*, *C* and *D*. Also identify the types of both the reactions. Metal present in *A* is used in alloy which is used for soldering purposes.

or

- (i) Crystals of a substance changed their colour on heating in a closed test tube but regained it after sometime when they were allowed to cool down. Name the substance, write its formula and explain the phenomenon involved.
 (ii) Name the compound whose one formula unit is associated with 10 water molecules. How is it prepared? Give equations of related reactions. Give two uses of the compound.

SECTION-E

Question no. 37 to 39 are case-based/data-based questions with 2 to 3 short sub-parts. Internal choice is provided in one of these sub-parts.

37. A student wants to project the image of a candle flame on the walls of the school laboratory by using a mirror.
 (i) Which type of mirror should he use and why?
 (ii) At what distance, in terms of focal length of the mirror, should he place the candle flame to get the magnified image on the wall?
- or
- (iii) Draw a ray diagram to show the formation of the image in this case.
 (iv) Can he use this mirror to project a diminished image of the candle flame on the same wall? State 'how' if your answer is 'yes' and 'why not' if your answer is 'no'.

Continue on next page.....

Click the Following Button to See the Free MS/Solutions

SOLUTIONS

38. Mrs. Tomar uses a compound of sodium X to make pakoras crispy. It is a mild non-corrosive basic salt, also used as an ingredient in antacids. It is produced using sodium chloride as one of the raw materials.
- Identify the compound of sodium X . Is the pH value of X solution lower than or higher than 7?
 - Write the chemical equation of preparation of X . Write the chemical reaction involved when X is heated.

or

State the chemical properties on which the following uses of X are based :

- as an antacid.
 - as a soda fire extinguisher.
39. An organism A which cannot move from one place to another, makes a simple food B from the substances C and D available in the environment. This food is made in the presence of a green coloured substance E present in organs F in the presence of light energy in a process called G . Some of the simple food B also gets converted into a complex food H for storage purposes. The food H gives a blue-black colour with dilute iodine solution.
- What is (a) organism A (b) food B , and (c) food H ?
 - What are C and D ?
 - In each of the following situations what happens to the rate of process G ?
 - Cloudy days.
 - Stomata get blocked due to dust.

or

- Explain the mechanism of process G .

□□□□□□

DOWNLOAD INDIA'S BEST STUDY MOBILE APP

- 30 Sample Paper with Solutions
- Chapterwise Question Bank of All Subject
- Previous 15 Years Solved Papers
- NCERT Solutions
- Case Study Questions with full Solutions
- **Word File of Material for Teachers**

Search by **NODIA** on Play Store to Download App

Add 89056 29969 in Your Class Whatsapp Group to Get Link

Click the Following Button to See the Free MS/Solutions

SOLUTIONS

Sample Paper 12

Class X 2023-24

Science (086)

Time: 3 Hours

Max. Marks: 80

General Instructions:

1. This question paper consists of 39 questions in 5 sections.
 2. All questions are compulsory. However, an internal choice is provided in some questions. A student is expected to attempt only one of these questions.
 3. Section A consists of 20 Objective Type questions carrying 1 mark each.
 4. Section B consists of 6 Very Short questions carrying 02 marks each. Answers to these questions should be in the range of 30 to 50 words.
 5. Section C consists of 7 Short Answer type questions carrying 03 marks each. Answers to these questions should be in the range of 50 to 80 words.
 6. Section D consists of 3 Long Answer type questions carrying 05 marks each. Answer to these questions should be in the range of 80 to 120 words.
 7. Section E consists of 3 source-based/case-based units of assessment of 04 marks each with sub-parts.
-

SECTION-A

Select and write one most appropriate option out of the four options given for each of the questions 1 – 20.

1.

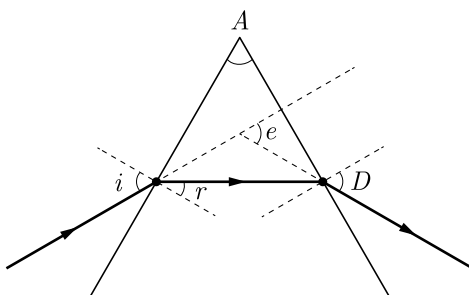

Which of the following angles are correctly marked in the above ray diagram?

- (a) $\angle i$, $\angle A$ and $\angle D$
 - (b) Only $\angle i$ and $\angle A$
 - (c) $\angle i$, $\angle r$ and $\angle A$
 - (d) All of the angles
2. Which of the following property is generally not shown by metals?
- (a) Electrical conduction
 - (b) Sonorous in nature
 - (c) Dullness
 - (d) Ductility

Continue on next page.....

Click the Following Button to See the Free MS/Solutions

SOLUTIONS

3. A highly reactive element (X) reacts with oxygen of air even at room temperature to give an oxide (Y). The oxide (Y) is soluble in water. The aqueous solution of (Y) does not change the colour of red litmus solution but reacts with an aqueous solution of sodium hydroxide. Here X is-
- (a) sodium
 - (b) phosphorus
 - (c) carbon
 - (d) sulphur
4. Choose the form in which most of the plants absorb nitrogen from the atmosphere?
- (a) Proteins
 - (b) Amino acids
 - (c) Atmospheric nitrogen
 - (d) Nitrates and nitrites
5. The clear sky appears blue as shown in the figure because



- (a) blue light gets absorbed in the atmosphere
 - (b) ultraviolet radiations are absorbed in the atmosphere
 - (c) violet and blue lights get scattered more than lights of all other colours by the atmosphere
 - (d) light of all other colours is scattered more than the violet and blue colour lights by the atmosphere
6. Which of the following is/are correct for olfactory indicators?
1. Their colour changes with acid or base.
 2. Onion, vanilla or clove are examples.
- (a) Only 1
 - (b) Only 2
 - (c) Both 1 and 2
 - (d) Neither 1 nor 2
7. What causes cramps in our muscles during sudden activity?
- (a) The pyruvate gets converted into lactic acid to release of energy.
 - (b) The pyruvate gets converted into carbon dioxide to release of energy.
 - (c) The pyruvate gets converted into ethanol to release of energy.
 - (d) The pyruvate gets converted into glucose to release of energy.

Continue on next page.....

Click the Following Button to See the Free MS/Solutions

SOLUTIONS

8. Chlorine reacts with saturated hydro-carbons at room temperature in the
- (a) absence of sunlight
 - (b) presence of sunlight
 - (c) presence of water
 - (d) presence of hydrochloric acid
9. An incident ray strikes a concave mirror after passing through the focus (F) as shown in the figure.

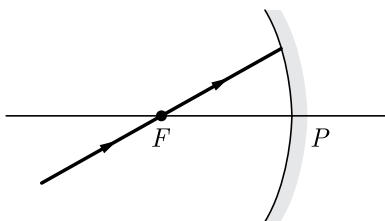

Which of the following shows the correct path of reflected rays?

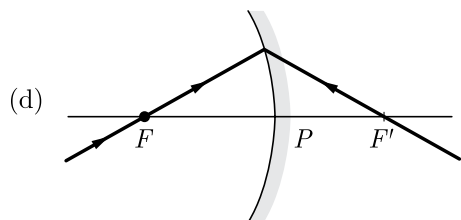
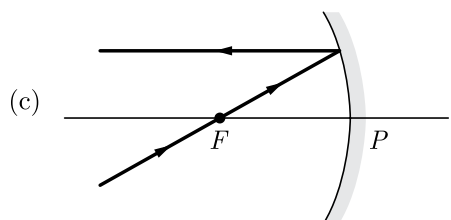
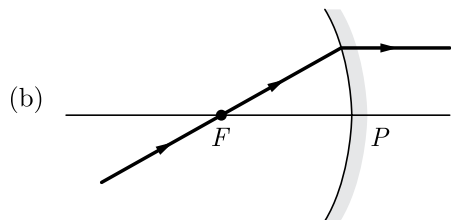
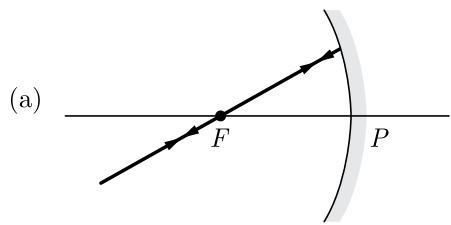

Continue on next page.....

Click the Following Button to See the Free MS/Solutions

SOLUTIONS

10. Oxygen gas reacts with hydrogen to produce water. The reaction is represented by the equation:

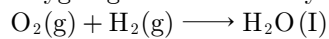

The above reaction is an example of

1. Oxidation of hydrogen
 2. Reduction of oxygen
 3. Reduction of hydrogen
 4. Redox reaction
- (a) 1, 2 and 3
(b) 2, 3 and 4
(c) 1, 3 and 4
(d) 1, 2 and 4
11. The shape of guard cells changes due to change in the

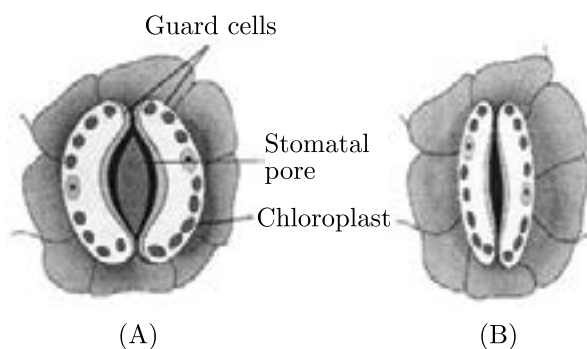

- (a) protein composition of cells
(b) temperature of cells
(c) amount of water in cells
(d) position of nucleus in the cells
12. The number of pair(s) of sex chromosomes in the zygote of humans is
- (a) one
(b) two
(c) three
(d) four
13. What happens when copper rod is dipped in iron sulphate solution?

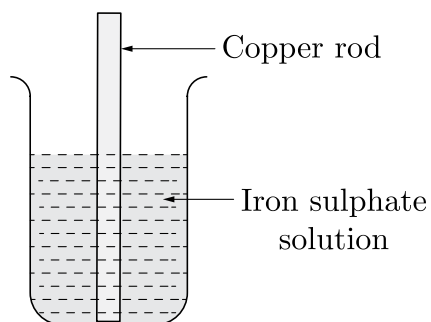

Continue on next page.....

Click the Following Button to See the Free MS/Solutions

SOLUTIONS

- (a) Copper displaces iron
(b) Blue colour of copper sulphate solution is obtained
(c) No reaction takes place
(d) Reaction is exothermic
14. A dilute ferrous sulphate solution was gradually added to the beaker containing acidified permanganate solution. The light purple colour of the solution fades and finally disappears. Which of the following is the correct explanation for the observation?
(a) KMnO_4 is an oxidising agent, it oxidises FeSO_4 .
(b) FeSO_4 acts as an oxidising agent and oxidises KMnO_4 .
(c) The colour disappears due to dilution; no reaction is involved.
(d) KMnO_4 is an unstable compound and decomposes in presence of FeSO_4 to a colourless compound.
15. Consider the following statements about refraction of light :

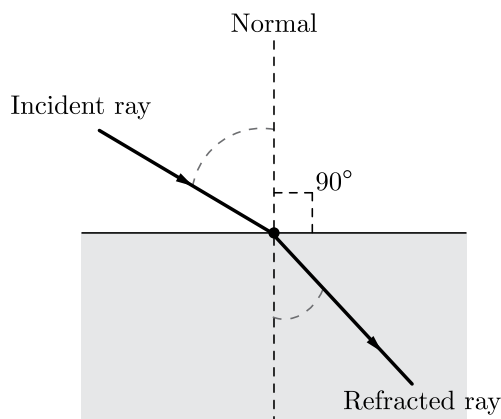

- The incident ray, refracted ray and the normal ray lie in the same plane.
 - The angle of incidence is equal to the angle of refraction.
- Choose the correct option from the codes given below:
- (a) Only 1
(b) Only 2
(c) Both 1 and 2
(d) Neither 1 nor 2
16. Offspring formed by asexual method of reproduction have greater similarity among themselves because
- asexual reproduction involves only one parent
 - asexual reproduction does not involve gametes
 - asexual reproduction occurs before sexual reproduction
 - asexual reproduction occurs after sexual reproduction
- (a) (i) and (ii)
(b) (i) and (iii)
(c) (ii) and (iv)
(d) (iii) and (iv)

Question no. 17 to 20 are Assertion - Reasoning based questions.

17. **Assertion :** A chemical reaction becomes faster at higher temperatures.
Reason : At higher temperatures, molecular motion becomes more rapid.
- Both Assertion and Reason are True and Reason is the correct explanation of the Assertion.
 - Both Assertion and Reason are True but Reason is not the Correct explanation of the Assertion.
 - Assertion is True but the Reason is False.
 - Both Assertion and Reason are False.
18. **Assertion :** Abscisic acid is a stress hormone.
Reason : Stimulation of ABA occurs in adverse conditions.
- Both assertion (A) and reason (R) are true and reason (R) is the correct explanation of assertion (A).
 - Both assertion (A) and reason (R) are true but reason (R) is not the correct explanation of assertion (A).
 - Assertion (A) is true but reason (R) is false.
 - Assertion (A) is false but reason (R) is true.
19. **Assertion :** Interventricular septum separates left from right atrium.
Reason : Interventricular septum separates left from right ventricle.
- Both Assertion and Reason are true and Reason is the correct explanation of Assertion.
 - Both Assertion and Reason are true but Reason is not the correct explanation of Assertion.
 - Assertion is true but Reason is false.
 - Assertion is false but Reason is true.
20. **Assertion :** When a battery is short-circuited, the terminal voltage is zero.
Reason : In the situation of a short-circuit, the current is zero
- Both assertion (A) and reason (R) are true and reason (R) is the correct explanation of assertion (A).
 - Both assertion (A) and reason (R) are true but reason (R) is not the correct explanation of assertion (A).
 - Assertion (A) is true but reason (R) is false.
 - Assertion (A) is false but reason (R) is true.

SECTION-B

Question no. 21 to 26 are very short answer questions.

21. What would you observe when zinc is added to a solution of iron(II) sulphate ? Write the chemical reaction that takes place.
- or**
- Name two metals that catch fire when put in water and why ?
22. When your finger is accidentally pricked by a needle, you instantaneously withdraw your hand. Which parts of your nervous system are involved in this response ?
23. What are the various situations about the variations?

Continue on next page.....

Click the Following Button to See the Free MS/Solutions

SOLUTIONS

24. Leaves of Bryophyllum fallen on the ground produce new plants, whereas the leaves of Jasmine do not. Why ?
25. Two lenses of power -2.5 D and $+1.5\text{ D}$ are placed in contact. Find the total power of the combination of lenses. Calculate the focal length of this combination.

or

An object placed at a distance of 30 cm in front of a convex mirror of focal length 15 cm. Write four characteristics of the image formed by the mirror.

26. Define food chain and write its two functions.

SECTION-C

Question no. 27 to 33 are short answer questions.

27. Which compounds are called (i) alkanes, (ii) alkenes and (iii) alkynes? C_4H_{10} belongs to which of these? Draw two structural isomers of this compound.
28. Write and balance the following questions presented to you as written statements :
- Magnesium carbonate plus hydrochloric acid produces magnesium chloride plus water plus carbon dioxide gas.
 - Aluminium plus chlorine gas produces aluminium trichloride.
 - Nitrogen plus hydrogen produces ammonia.
29. (a) Define hormone. Write four characteristics in humans.
(b) Name the disorder caused by the following situations :
- Under secretion of growth hormone
 - Over secretion of growth hormone
 - Under secretion of insulin
 - Deficiency of iodine.

or

Name any three endocrine glands in human body and briefly write the function of each of them.

30. A person wears spectacles of power -2.5 D . Name the defect of vision he is suffering from. Draw the ray diagram for (i) the defective eye, (ii) its correction after using a suitable lens.
31. Study the diagram below and answer the following questions :

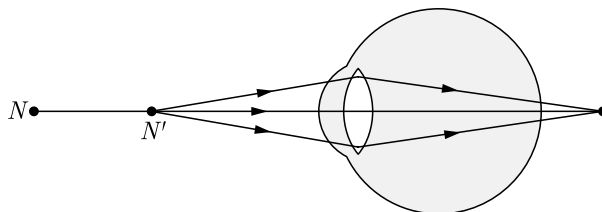

- Name the defect of vision depicted in the diagram.
- List two causes of the above defect.
- Draw a ray diagram for the correction of the above defect using an appropriate lens.

Continue on next page.....

Click the Following Button to See the Free MS/Solutions

SOLUTIONS

32. Draw a circuit diagram of an electric circuit containing a cell, a key, an ammeter, a resistor of $4\ \Omega$ in series with a combination of two resistors ($8\ \Omega$ each) in parallel and a voltmeter across parallel combination. Each of them dissipate maximum energy and can withstand a maximum power of 16W without melting. Find the maximum current that can flow through the three resistors.

or

Derive an expression for equivalent resistance when two resistors of resistance R_1 and R_2 are connected in parallel.

33. How do organisms, whether reproduced asexually or sexually maintain a constant chromosome number through several generations? Explain with the help of suitable example.

SECTION-D

Question no. 34 to 36 are Long answer questions.

34. Explain the following :

- Metals at the top of the reactivity series do not occur in the free state in nature.
- Finely powdered ore is mixed with a suitable oil and water in the concentration of a sulphide ore.
- Sulphide ores need to be roasted after concentration.
- Mercury can be obtained just by roasting the ore.
- Highly reactive metals are obtained by electrolytic reduction of their compounds.

or

- Define corrosion.
- What is corrosion of iron called ?
- How will you recognise the corrosion of silver ?
- Why corrosion of iron is a serious problem ?
- How can we prevent corrosion of iron ?

35. (a) State any two changes seen in boys at the time of puberty.
(b) Define fertilization and implantation.
(c) State the role of ovary and fallopian tube in human body.

or

- Write the functions of the following parts in human female reproductive system :
(i) Ovary, (ii) Oviduct, (iii) Uterus.
- Write the structure and function of placenta.

36. (i) Consider a conductor of resistance R , length L , thickness d and resistivity ρ . Now this conductor is cut into four equal parts. What will be the new resistivity of each of these parts? Why?
(ii) Find the resistance if all of these parts are connected in:
(a) Parallel
(b) Series
(iii) Out of the combinations of resistors mentioned above in the previous part, for a given voltage which combination will consume more power and why?

Click the Following Button to See the Free MS/Solutions

SOLUTIONS

SECTION-E

Question no. 37 to 39 are case-based/data-based questions with 2 to 3 short sub-parts. Internal choice is provided in one of these sub-parts.

37. Baking soda is used in small amounts for making bread and cakes. It helps to make these soft and spongy. An aqueous solution of baking soda turns red litmus blue. It is also used in soda acid fire extinguisher. Use this information to answer the following questions.

- (i) Write the equation for the reaction between baking soda and acid.
- (ii) How does it help in extinguishing fire?
- (iii) What is the reaction involved when it is heated?

or

- (iv) Is the pH value of baking soda solution lower than or higher than 7 ?

38. In our country, ultrasound imaging (echography) is used to take images of the developing babies (foetus). It is considered safe for both the mother and the foetus. In this method, the doctor holds a probe and moves it across the abdomen of the mother.

Ultrasound waves which are transmitted into the abdomen are reflected from the surface of the foetus. These reflected waves are picked up by the probe and relayed to a machine that produces the image of the developing baby. In some parts of our country, ultrasound is done illegally.

- (i) What could be the reason of performing ultrasound illegally?
- (ii) “Man, and not the woman is responsible for the birth of a girl child.” What is meant by this statement?
- (iii) Can ultrasound examination of expecting mothers answer the following questions? Write ‘Yes’ or ‘No’.
 - (a) What is the colour of the baby’s eyes?
 - (b) Is there more than one foetus?

or

- (iv) Based on the data shown in the graph alongside, state what could be the reason for the decline in the boys child sex ratio ?

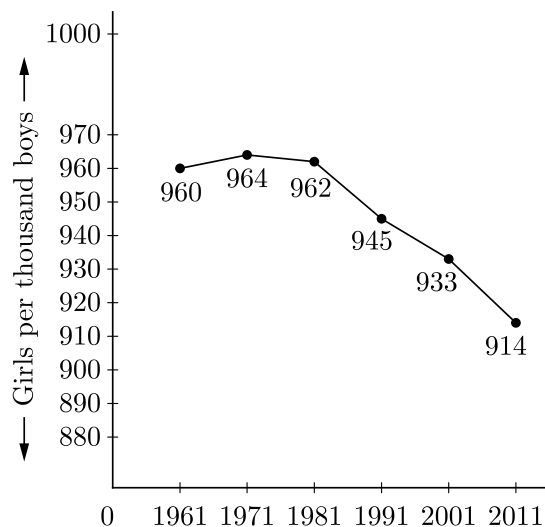

Continue on next page.....

Click the Following Button to See the Free MS/Solutions

SOLUTIONS

39. The lens of the eye does little of the bending of the light rays. Most of the refraction is done at the front surface of the cornea which also acts as a protective covering. The lens acts as a fine adjustment for focussing at different distances. This is accomplished by the ciliary muscle, which change the curvature of the lens so that its focal length is changed. To focus on a distant object, the muscles are relaxed and the lens is thin and parallel rays focus at the focal point (on the retina). To focus on a nearby object, the muscles contract, causing the centre of the lens to be thicker, thus shortening the focal length so that images of nearby objects can be focused on the retina, behind the focal point. This focusing adjustment is called accommodation.

The closest distance at which the eye can focus clearly is called the near point of the eye. A given person's far point is the farthest distance at which an object can be seen clearly. To check your own near point, place this book close to your eye and slowly move it away until the type is sharp.

A large part of the population have eyes that do not accommodate within the normal range of 25 cm to infinity, or have some other defect. Two common defects are near-sightedness and far-sightedness. Both can be corrected to a large extent with lenses—either eyeglasses or contact lenses.

- (i) The ciliary muscle muscles of a normal eye are in their (i). most relaxed (ii). most contracted state. In which of the two cases is the focal length of the eye-lens more ?
- (ii) What is the least distinct of vision of young man ?
- (iii) What is persistence of vision ?

or

- (iv) What is meant by power of accommodation of the eye?

□□□□□□

DOWNLOAD INDIA'S BEST STUDY MOBILE APP

- 30 Sample Paper with Solutions
- Chapterwise Question Bank of All Subject
- Previous 15 Years Solved Papers
- NCERT Solutions
- Case Study Questions with full Solutions
- **Word File of Material for Teachers**

Search by NODIA on Play Store to Download App

Add 89056 29969 in Your Class Whatsapp Group to Get Link

Click the Following Button to See the Free MS/Solutions

SOLUTIONS

Sample Paper 13

Class X 2023-24

Science (086)

Time: 3 Hours

Max. Marks: 80

General Instructions:

1. This question paper consists of 39 questions in 5 sections.
 2. All questions are compulsory. However, an internal choice is provided in some questions. A student is expected to attempt only one of these questions.
 3. Section A consists of 20 Objective Type questions carrying 1 mark each.
 4. Section B consists of 6 Very Short questions carrying 02 marks each. Answers to these questions should be in the range of 30 to 50 words.
 5. Section C consists of 7 Short Answer type questions carrying 03 marks each. Answers to these questions should be in the range of 50 to 80 words.
 6. Section D consists of 3 Long Answer type questions carrying 05 marks each. Answer to these questions should be in the range of 80 to 120 words.
 7. Section E consists of 3 source-based/case-based units of assessment of 04 marks each with sub-parts.
-

SECTION-A

Select and write one most appropriate option out of the four options given for each of the questions 1 – 20.

1. Which of the following I-V graph represents for ohmic conductors?

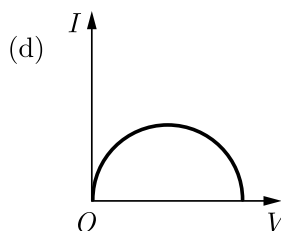
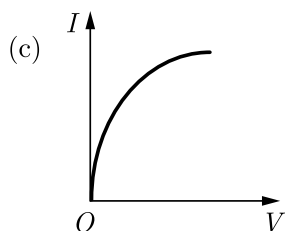
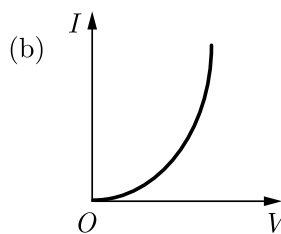
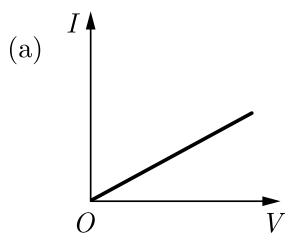

Continue on next page.....

Click the Following Button to See the Free MS/Solutions

SOLUTIONS

2. Identify the correct representation of reaction occurring during chlor-alkali process:

- (a) $2\text{NaCl}(aq) + 2\text{H}_2\text{O}(aq) \longrightarrow 2\text{NaOH}(aq) + \text{Cl}_2(g) + \text{H}_2(g)$
- (b) $2\text{NaCl}(l) + 2\text{H}_2\text{O}(l) \longrightarrow 2\text{NaOH}(l) + \text{Cl}_2(g) + \text{H}_2(g)$
- (c) $2\text{NaCl}(aq) + \text{H}_2\text{O}(l) \longrightarrow 2\text{NaOH}(aq) + \text{Cl}_2(g) + \text{H}_2(g)$
- (d) $2\text{NaCl}(aq) + 2\text{H}_2\text{O}(l) \longrightarrow 2\text{NaOH}(aq) + \text{Cl}_2(aq) + \text{H}_2(aq)$

3. In the following circuits, heat produced in the resistor or combination of resistors connected to a 12 V battery will be:

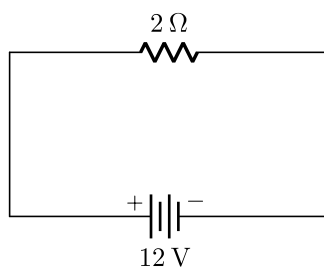

(i)

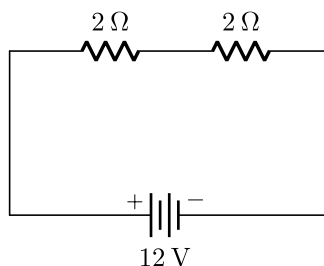

(ii)

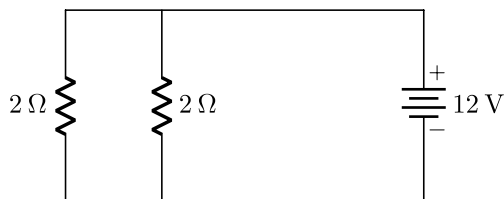

(iii)

- (a) minimum in case (i)
- (b) same in all the cases
- (c) maximum in case (iii)
- (d) maximum in case (ii)

Click the Following Button to See the Free MS/Solutions

SOLUTIONS

4. If an electron is travelling horizontally towards east, a magnetic field in vertically downward direction exerts a force on the electron along:
- west
 - east
 - south
 - north
5. Carefully study the diagram of human excretory system with labels *A*, *B* and *C*. Select the option which gives correct function of B.

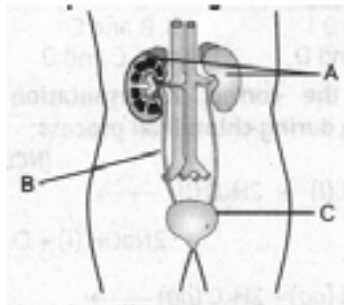

- carry urine from kidney to urinary bladder
 - contain urine till is released out
 - passage through which urine is excreted out of the body.
 - guard the urethra
6. Which organism reproduces by the method shown in the given figure?



- Amoeba
 - Plasmodium
 - Paramecium
 - Leishmania
7. Dramatic changes of body features associated with puberty are mainly because of secretion of:
- oestrogen from adrenal gland and testosterone from pituitary gland
 - oestrogen from testes and testosterone from ovary
 - testosterone from thyroid gland and oestrogen from pituitary gland
 - testosterone from testes and oestrogen from ovary

Continue on next page.....

Click the Following Button to See the Free MS/Solutions

SOLUTIONS

8. Observe the diagram of Human digestive system.

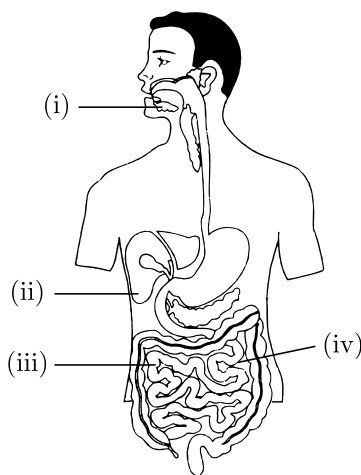

Match the labelling referred in column I and correlate with the function in column II.

Column I		Column II
(i)	(A)	The length of this depends on food the organism eats.
(ii)	(B)	Initial phase of starch digestion.
(iii)	(C)	Increases the efficiency of lipase enzyme action.
(iv)	(D)	This is the site of the complete digestion of carbohydrates, proteins and fats.

- (a) (i)-(A), (ii)-(B), (iii)-(C), (iv)-(D)
 (b) (i)-(B), (ii)-(C), (iii)-(D), (iv)-(A)
 (c) (i)-(B), (ii)-(D), (iii)-(C), (iv)-(A)
 (d) (i)-(D), (ii)-(A), (iv)-(B), (IV)-(C)

9. In the reaction of iron with copper sulphate solution:



Which option in the given table correctly represents the substance oxidised and the reducing agent?

Option	Substance oxidised	Reducing agent
a.	Fe	Fe
b.	Fe	FeSO ₄
c.	Cu	Fe
d.	CuSO ₄	Fe

10. C⁴⁺ does not exist but Pb⁴⁺ exists although both belong to the same group. This is because:

- (i) size of carbon is much smaller than Pb.
 (ii) large amount of energy is needed in case of carbon.
 (iii) of inert pair effect.
 (iv) nucleus cannot hold such a large number of electrons.

The correct statement(s) is/are:

- (a) (i) and (ii)
 (b) Only (i)
 (c) (ii), (iii) and (iv)
 (d) Only (iii)

Click the Following Button to See the Free MS/Solutions

SOLUTIONS

11. The diagram shows the electrolysis of water.

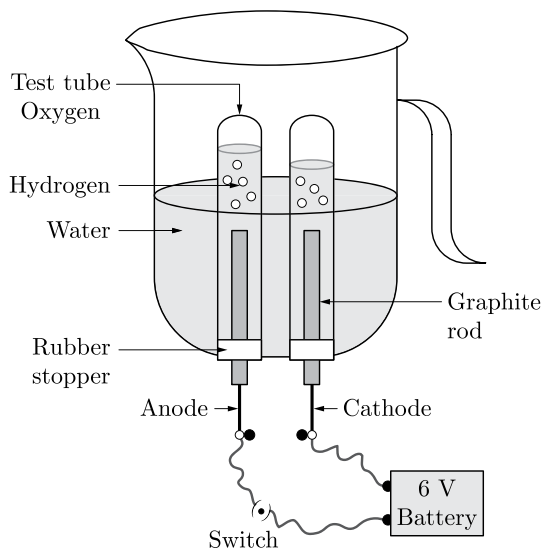

A few drops of H_2SO_4 are added to pure water because :

- (a) pure water is a bad conductor of electricity
 (b) it does not conduct electricity
 (c) Both *b.* and *c.*
 (d) it makes the reaction faster
12. Which of the following correctly represents a balanced chemical equation?
- (a) $3\text{Fe}(s) + 4\text{H}_2\text{O}(g) \longrightarrow \text{Fe}_3\text{O}_4(s) + 4\text{H}_2\text{O}(g)$
 (b) $\text{Fe}(s) + 4\text{H}_2\text{O}(g) \longrightarrow \text{Fe}_3\text{O}_4(s) + 4\text{H}_2\text{O}(g)$
 (c) $3\text{Fe}(s) + 4\text{H}_2\text{O}(g) \longrightarrow \text{Fe}_3\text{O}_4(s) + \text{H}_2(g)$
 (d) $3\text{Fe}(s) + \text{H}_2\text{O}(g) \longrightarrow \text{Fe}_3\text{O}_4(s) + \text{H}_2(g)$
13. Identify gas A in the following experiment.

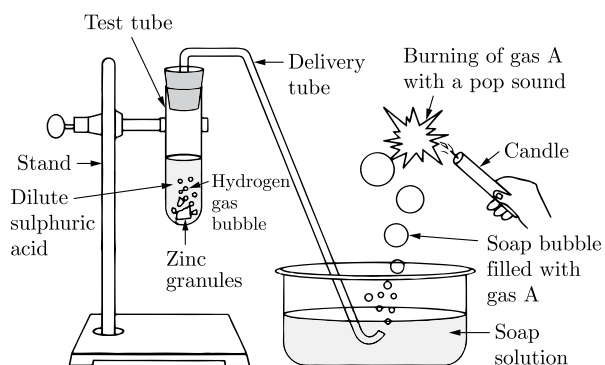

- (a) Hydrogen
 (b) Nitrogen
 (c) Carbon dioxide
 (d) Oxygen

Click the Following Button to See the Free MS/Solutions

SOLUTIONS

14. A student arranges an electric circuit as shown in figure :

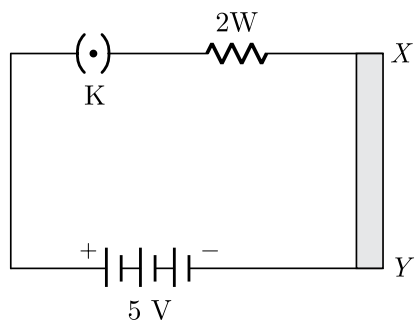

He gently puts the compass needle near the thick copper wire XY . He observes that compass needle shows deflection as soon as key (K) is inserted. What does this depict?

- (a) The compass needle is faulty.
 (b) There is a magnetic field around the conductor XY
 (c) Connections in the circuit are not proper.
 (d) Heating effect of current causes deflection in compass needle.
15. In human males, all the chromosomes are paired perfectly except one. This/these unpaired Chromosome is/are:
- (i) large chromosome
 (ii) small chromosome
 (iii) Y-chromosome
 (iv) X-chromosome
- (a) Only (iii)
 (b) (i) and (ii)
 (c) (ii) and (iv)
 (d) (iii) and (iv)
16. The table shown below gives information about four substances: A , B , C and D .

Substance	Melting point (k)	Electrical Conductivity	
		Solid	Liquid/Aqueous
A.	295	Good	Good
B.	1210	Good	Good
C.	1890	Good	Good
D.	1160	Good	Poor

Identify Ionic compounds from the above given substances.

- (a) B and C
 (b) A and B
 (c) A, C and D
 (d) A, B and D

Question no. 17 to 20 are Assertion-Reasoning based questions.

- 17. Assertion (A):** The uterine lining in human females becomes thick and spongy every month.
Reason (R): The lining breaks and comes out through the vagina as blood and mucus if fertilisation does not occur.
- (a) Both Assertion (A) and Reason (R) are true and Reason (R) is the correct explanation of Assertion (A).
 - (b) Both Assertion (A) and Reason (R) are true but Reason (R) is not the correct explanation of Assertion (A).
 - (c) Assertion (A) is true but Reason (R) is fake.
 - (d) Assertion (A) is fake but Reason (R) is true.
- 18. Assertion (A):** Two resistances having value R each. Their equivalent resistance is $= \frac{R}{2}$
Reason (R): Given resistances are connected in parallel.
- (a) Both Assertion (A) and Reason (R) are true and Reason (R) is the correct explanation of Assertion (A).
 - (b) Both Assertion (A) and Reason (R) are true but Reason (R) is not the correct explanation of Assertion (A).
 - (c) Assertion (A) is true but Reason (R) is fake.
 - (d) Assertion (A) is fake but Reason (R) is true.
- 19. Assertion (A):** Excretion is the biological process by which harmful wastes are removed from an organism's body.
Reason (R): The mode of excretion is same in both unicellular and multicellular organisms.
- (a) Both Assertion (A) and Reason (R) are true and Reason (R) is the correct explanation of Assertion (A).
 - (b) Both Assertion (A) and Reason (R) are true but Reason (R) is not the correct explanation of Assertion (A).
 - (c) Assertion (A) is true but Reason (R) is fake.
 - (d) Assertion (A) is fake but Reason (R) is true.
- 20. Assertion (A):** White silver chloride turns grey in sunlight.
Reason (R): Decomposition of silver chloride in presence of sunlight takes place to form silver metal and chlorine gas.
- (a) Both Assertion (A) and Reason (R) are true and Reason (R) is the correct explanation of Assertion (A).
 - (b) Both Assertion (A) and Reason (R) are true but Reason (R) is not the correct explanation of Assertion (A).
 - (c) Assertion (A) is true but Reason (R) is fake.
 - (d) Assertion (A) is fake but Reason (R) is true.

SECTION-B

Question no. 21 to 26 are very short answer questions.

- 21.** Why is Tyndall effect shown by colloidal particles? State four instances of observing the Tyndall effect.
- or**
- (i) Why is red used as the stopping light at traffic signals?
 - (ii) Two triangular glass prisms are kept together connected through their rectangular side. A light beam is passed through one side of the combination. Will there be any dispersion? Justify your answer.

Continue on next page.....

Click the Following Button to See the Free MS/Solutions

SOLUTIONS

22. In the following food chain, vertical arrows indicate the energy lost to the environment and horizontal arrows indicate energy transferred to the next trophic level. Which one of the three vertical arrows (*A*, *C* and *E*) and which one of the two horizontal arrows (*B* and *D*) will represent more energy transfer? Give reason for your answer.

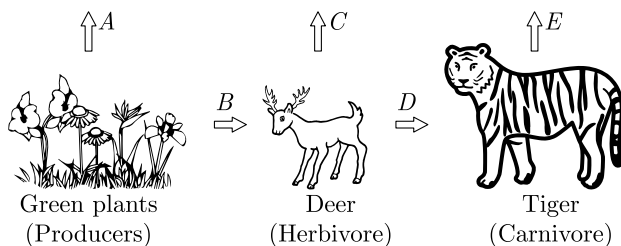

A food chain in a forest ecosystem

23. (i) What is lymph?
 (ii) Give two functions of blood.
24. Explain the processes of aerobic respiration in mitochondria of a cell and anaerobic respiration in yeast and muscle with the help of word equations.
25. You might have noted that when copper powder is heated in a China dish, the surface of copper powder becomes coated with a black colour substance.
 (i) How has this black-coloured substance formed?
 (ii) What is that black substance?
 (iii) Write the chemical equation of the reaction that takes place.
- or**
- You have four solutions *A*, *B*, *C* and *D*. The pH of solution *A* is 6, *B* is 9, *C* is 12 and *D* is 7.
 (i) Identify the most acidic and most basic solutions.
 (ii) Arrange the above four solutions in the increasing order of H^+ ion concentration.
26. How is the movement of leaves of the sensitive plants different from the movement of a shoot towards light.

SECTION-C

Question no. 27 to 33 are short answer questions.

27. Of the three metals *X*, *Y* and *Z*. *X* reacts with cold water. *Y* with hot water and *Z* with steam only. Identify *X*, *Y* and *Z* and also arrange them in order of increasing reactivity.
28. (i) Under what conditions permanent electromagnet is obtained if a current carrying solenoid is used?
 (ii) A magnetic compass shows a deflection when placed near a current carrying wire. How will the deflection of the compass get affected if the current in the wire is increased ?

Continue on next page.....

Click the Following Button to See the Free MS/Solutions

SOLUTIONS

29. Complete the following flow chart based on ecosystem and its components.

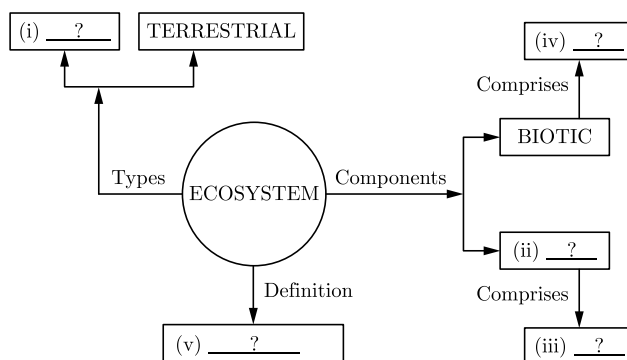

or

- (i) From the following group of organisms, create a food chain which is the most advantageous for human beings in terms of energy :

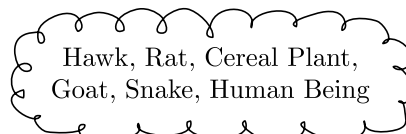

- (ii) State the possible disadvantage if the cereal plant is growing in soil rich in pesticides.
 (iii) Construct a food web using the organisms mentioned above.
30. It is desired to obtain an erect image of an object, using concave mirror of focal length of 12 cm.
 (i) What should be the range of the object distance in the above case?
 (ii) Will the image be smaller or larger than the object? Draw a ray diagram to show the formation of image in this case.
 (iii) Where will the image of this object be, if it is placed 24 cm in front of the mirror?
31. A hydrocarbon molecule has the structure given below:

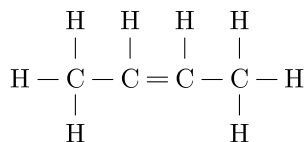

- (i) Write the equation for the combustion of this hydrocarbon molecule in oxygen.
 (ii) The given molecule can be hydrogenated to produce an alkane molecule. Name it.
 (iii) Give the reaction conditions for the above conversion.
32. List in tabular form three differences between arteries and veins.

or

Compare the functioning of alveoli in the lungs and nephrons in the kidneys.

Continue on next page.....

Click the Following Button to See the Free MS/Solutions

SOLUTIONS

33. (i) State laws of refraction of light.
 (ii) The power of a lens is +5 diopters. What is the nature and focal length of this lens? At what distance from this lens should an object be placed so as to get its inverted image of the same size?

SECTION-D

Question no. 34 to 36 are Long answer questions.

34. (i) Identify the given diagram. Name the parts 1 to 5.

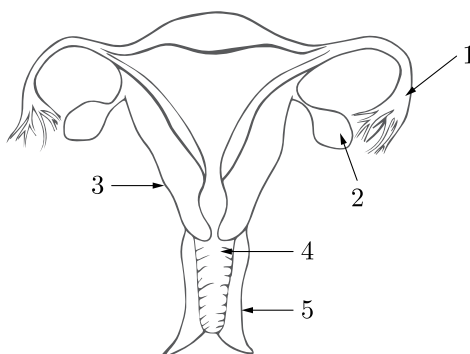

- (ii) What is contraception? List three advantages of adopting contraceptive measures.
- or**
- (i) Write one main difference between asexual and sexual mode of reproduction. Which species is likely to have comparatively better chances of survival—the one reproducing asexually or the one reproducing sexually? Give reason to justify your answer.
- (ii) What is carpel? Write the function of its various parts.
35. A metal M is stored under kerosene. It vigorously catches fire, if a small piece of this metal is kept open in air. Dissolution of this metal in water releases great amount of energy and the metal catches fire. The solution so formed turns red litmus blue.
- (i) Name the metal M .
- (ii) Write formula of the compound formed when this metal is exposed to air.
- (iii) Why is metal M stored under kerosene?
- (iv) If oxide of this metal is treated with hydrochloric acid, what would be the products?
- (v) Write balanced equations for:
- Reaction of ' M ' with air.
 - Reaction of ' M ' with water.
 - Reaction of metal oxide with hydrochloric acid.
- or**
- (i) Write the steps involved in the extraction of pure metals in the middle of the activity series from their carbonate ores.
- (ii) How is copper extracted from its sulphide ore? Explain the various steps supported by chemical equations. Draw labelled diagram for the electrolytic refining of copper.

Continue on next page.....

Click the Following Button to See the Free MS/Solutions

SOLUTIONS

36. (i) For the combination of resistors shown in the following figure, find the equivalent resistance between M and N :

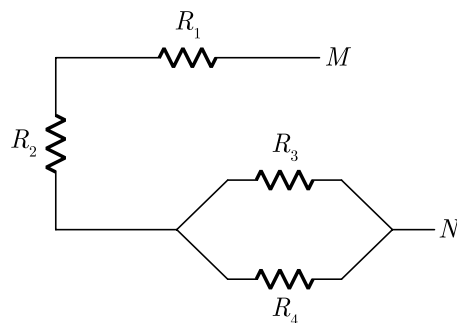

- (ii) State Joule's law of heating.
 (iii) Why we need a 5A fuse for an electric iron which consumes 1 kW power at 220 V?
 (iv) Why is it impracticable to connect an electric bulb and an electric heater in series?

SECTION-E

Question no. 37 to 39 are case-based/data-based questions with 2 to 3 short sub-parts. Internal choice is provided in one of these sub-parts.

37. Refer to the given table regarding results of F_2 generation of Mendelian cross.

Plants with round and yellow coloured seeds (P)	315
Plants with round and green coloured seeds (Q)	108
Plants with wrinkled and yellow coloured seeds (R)	101
Plants with wrinkled and green coloured seeds (S)	32

- (i) What would be the phenotype of F_1 generation regarding given data of F_2 generation?
 (ii) What would be the genotype of parental generation regarding given result of F_2 generation?
 (iii) If plant with wrinkled and green coloured seeds (S) is crossed with plant having wrinkled and yellow coloured seeds (R), what will be the probable phenotype of offsprings?

or

- (iv) If YYRR is round yellow, what do the following represent?
 yyrr, yyRR.

38. The table shows some information about compounds in homologous series.

Name of Compound	Molecular Formula	Molecular Mass	Boiling Point
Methanoic acid	HCOOH	46	100.8°C
Ethanoic acid	CH ₃ COOH	60	118°C
Propanoic acid	C ₂ H ₅ COOH	74	141°C
Butanoic acid	C ₃ H ₇ COOH	88	163°C
Pentanoic acid	C ₄ H ₉ COOH	102	186°C

Continue on next page.....

Click the Following Button to See the Free MS/Solutions

SOLUTIONS

- (i) Predict the molecular mass of the compound in the same series which has six carbon atoms in one molecule. Write the general formula for a compound in this homologous series.
- (ii) Draw the structural formula of propanoic acid. Why ethanoic acid is called glacial acetic acid?
- or**
- (iii) Draw the electron dot structure of ethanoic acid.

39. Figure A and B show the ray diagrams related to defects of vision. Study the diagrams and answer the questions:

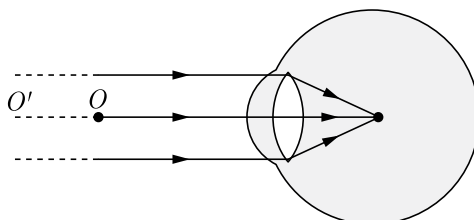

A Defect of vision in patient X

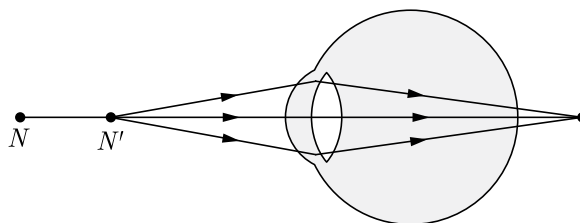

B Defect of vision in patient Y

- (i) Refer to fig. B and fig. A, showing the defects of vision in patients Y and X. Infer the defects which can be diagnosed from the given ray diagrams.
- (ii) Identify the eye defect resulting due to the eye lens becoming cloudy.
- (iii) Based on the spectacles given below, infer the eye defect which can be diagnosed from it. Also List two causes of this defect.

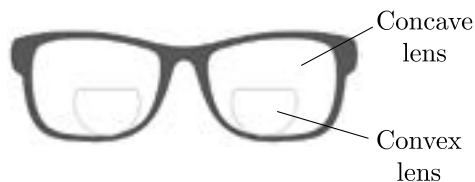

or

- (iv) The patient X needs a lens of power -4.5D for correction of his vision.
- (a) What is the focal length of the corrective lens?
- (b) What is the nature of corrective lens?

□□□□□□

Click the Following Button to See the Free MS/Solutions

SOLUTIONS

Sample Paper 14

Class X 2023-24

Science (086)

Time: 3 Hours

Max. Marks: 80

General Instructions:

1. This question paper consists of 39 questions in 5 sections.
2. All questions are compulsory. However, an internal choice is provided in some questions. A student is expected to attempt only one of these questions.
3. Section A consists of 20 Objective Type questions carrying 1 mark each.
4. Section B consists of 6 Very Short questions carrying 02 marks each. Answers to these questions should be in the range of 30 to 50 words.
5. Section C consists of 7 Short Answer type questions carrying 03 marks each. Answers to these questions should be in the range of 50 to 80 words.
6. Section D consists of 3 Long Answer type questions carrying 05 marks each. Answer to these questions should be in the range of 80 to 120 words.
7. Section E consists of 3 source-based/case-based units of assessment of 04 marks each with sub-parts.

SECTION-A

Select and write one most appropriate option out of the four options given for each of the questions 1 – 20.

1. In the given activity, the lime water of which test tube will get milky faster?

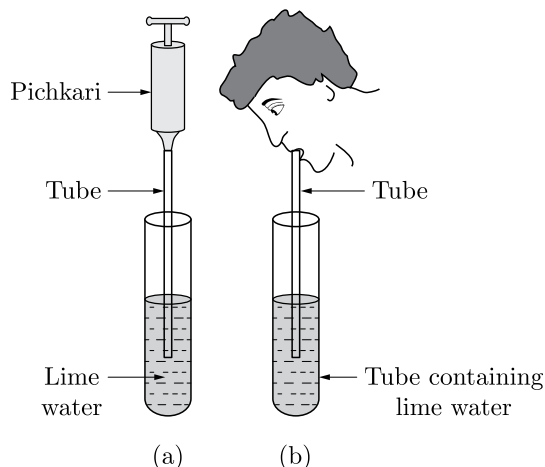

- (a) Test tube (a)
(b) Test tube (b)
(c) Both test tube will take same time
(d) Can't say
2. Which of the following are used as an antacid to reduce acidity in stomach?
(a) Sodium carbonate and magnesium hydroxide
(b) Magnesium hydroxide and sodium hydroxide
(c) Sodium bicarbonate and calcium hydroxide
(d) Sodium bicarbonate and magnesium hydroxide

Click the Following Button to See the Free MS/Solutions

SOLUTIONS

3. The resistivity does not change if
- the material is changed
 - the temperature is changed
 - the shape of the resistor is changed
 - both material and temperature are changed
4. The most important safety method used for protecting home appliances from short circuiting or overloading is
- earthing
 - use of fuse
 - use of stabilizers
 - use of electric meter.
5. A uniform magnetic field exists in the plane of paper pointing from left to right as shown in Figure. In the field an electron and a proton move as shown. The electron and the proton experience.

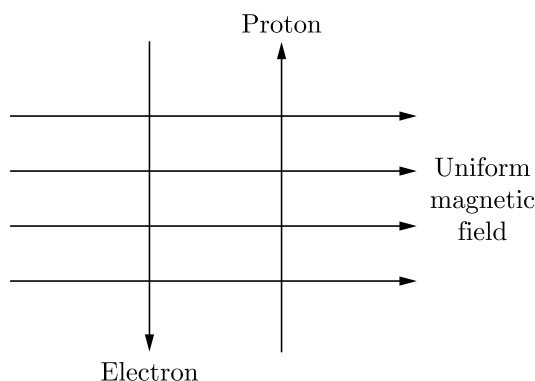

- forces both pointing into the plane of paper
 - forces both pointing out of the plane of paper
 - forces pointing into the plane of paper and out of the plane of paper, respectively.
 - force pointing opposite and along the direction of the uniform magnetic field respectively.
6. An element X has electronic configuration 2, 8, 1 and another element Y has electronic configuration 2, 8, 7. They form a compound Z . The property that is not exhibited by Z is
- It has high melting point.
 - It is a good conductor of electricity in its pure solid state.
 - It breaks into pieces when beaten with hammer.
 - It is soluble in water
7. $Y + 2\text{HCl} \longrightarrow \text{ZnCl}_2 + \text{H}_2$. In the above reaction, Y is:
- Aluminium
 - Copper
 - Sodium
 - Zinc

Continue on next page.....

Click the Following Button to See the Free MS/Solutions

SOLUTIONS

8. Which one of the following pair is correct?

	Reaction	Reaction Type
(a)	$2\text{KNO}_3(\text{s}) \rightarrow 2\text{KNO}_2(\text{s}) + \text{O}_2(\text{g})$	Displacement reaction
(b)	$\text{Zn}(\text{s}) + 2\text{AgNO}_3(\text{aq}) \rightarrow \text{Zn}(\text{NO}_3)_2 + 2\text{Ag}(\text{s})$	Combination reaction
(c)	$\text{Ni}(\text{NO}_3)_2(\text{aq}) + 2\text{NaOH} \rightarrow \text{Ni}(\text{OH})_2 \downarrow + 2\text{NaNO}_3(\text{aq})$	Double displacement reaction and precipitation reaction
(d)	$\text{N}_2(\text{g}) + 3\text{H}_2(\text{g}) \rightarrow 2\text{NH}_3(\text{g})$	Decomposition reaction

9. Equal volumes of hydrochloric acid and sodium hydroxide solutions of same concentration are mixed and the pH of the resulting solution is checked with a pH paper. What would be the colour obtained?



- (a) Red
 (b) Yellow
 (c) Yellowish green
 (d) Blue
10. Exchange of genetic material takes place in
 (a) vegetative reproduction
 (b) asexual reproduction
 (c) sexual reproduction
 (d) budding
11. When a person eats some egg white, proteins and water enter the stomach. Which substances are found leaving the stomach and leaving the small intestine?

	Leaving the Stomach	Leaving the Small Intestine
(a)	Protein, amino acids and water	Water
(b)	Amino acids and water	Amino acids and water
(c)	Fatty acids, glycerol and water	Fatty acids, glycerol and water
(d)	Protein and water	Fatty acids and glycerol

12. A cell, a resistor, a key and ammeter are arranged as shown in the circuit diagrams of Figure. The current recorded in the ammeter will be

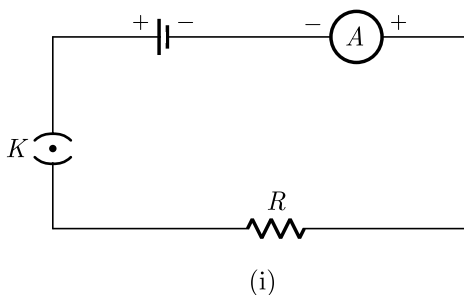

Continue on next page.....

Click the Following Button to See the Free MS/Solutions

SOLUTIONS

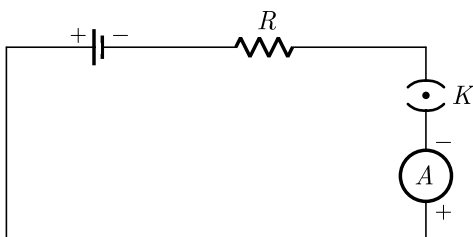

(ii)

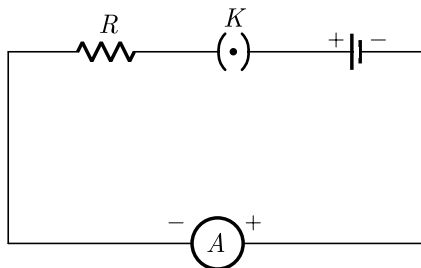

(iii)

- (a) maximum in (i)
- (b) maximum in (ii)
- (c) maximum in (iii)
- (d) the same in all the cases

13. Which of the following is correct for a physical change?

1. Only physical properties change.
2. Large amount of heat is absorbed or evolved.

Which of the above statements is/are correct?

- (a) Only 1
- (b) Only 2
- (c) Both 1 and 2
- (d) Neither 1 and 2

14. Which among the following statements are true for sexual reproduction in flowering plants?

- (i) It requires two types of gametes
- (ii) Fertilisation is a compulsory event
- (iii) It always results in formation of zygote
- (iv) Offsprings formed are clones

- (a) (i) and (iv)
- (b) (i), (ii) and (iv)
- (c) (i), (ii) and (iii)
- (d) (i), (iii) and (iv)

15. When a person is suffering from severe cold, he or she cannot

- (a) differentiate the taste of an apple from that of an ice cream.
- (b) differentiate the smell of a perfume from that of an agarbatti.
- (c) differentiate red light from green light
- (d) differentiate a hot object from a cold object.

Continue on next page.....

Click the Following Button to See the Free MS/Solutions

SOLUTIONS

16. Structural formula of benzene is

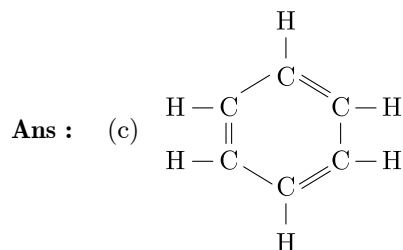
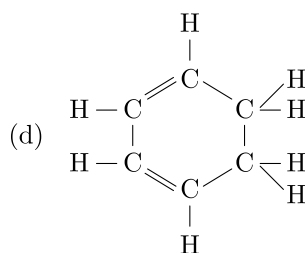
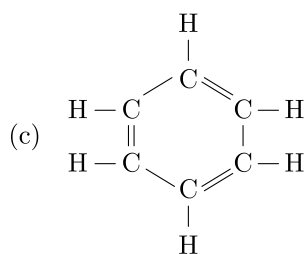
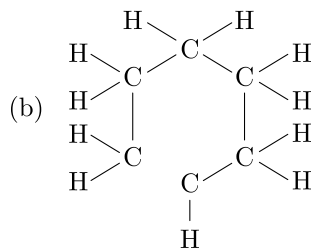
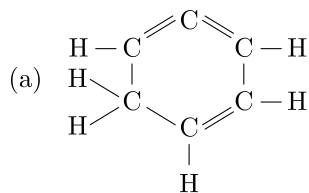

Question no. 17 to 20 are Assertion - Reasoning based questions.

17. **Assertion :** When water is added to calcium oxide, a large amount of heat is produced.

Reason : It is an endothermic reaction.

- (a) Both Assertion and Reason are True and Reason is the correct explanation of the Assertion.
 (b) Both Assertion and Reason are True but Reason is not the Correct explanation of the Assertion.
 (c) Assertion is True but the Reason is False.
 (d) Both Assertion and Reason are False.

Continue on next page.....

Click the Following Button to See the Free MS/Solutions

SOLUTIONS

18. **Assertion :** The genetic complement of an organism is called genotype.
Reason : Genotype is the type of hereditary properties of an organism.
- Both assertion (A) and reason (R) are true and reason (R) is the correct explanation of assertion (A).
 - Both assertion (A) and reason (R) are true but reason (R) is not the correct explanation of assertion (A).
 - Assertion (A) is true but reason (R) is false.
 - Assertion (A) is false but reason (R) is true.
19. **Assertion :** During the night the effect of root pressure in transport of water is more important.
Reason : Stomata is open during day, transpiration takes place which help in transport of water.
- Both Assertion and Reason are true and Reason is the correct explanation of Assertion.
 - Both Assertion and Reason are true but Reason is not the correct explanation of Assertion.
 - Assertion is true but Reason is false.
 - Both Assertion and Reason are false.
20. **Assertion :** A solenoid tends to expand, when a current passes through it.
Reason : Two straight parallel metallic wires carrying current in same direction attract each other.
- Both assertion (A) and reason (R) are true and reason (R) is the correct explanation of assertion (A).
 - Both assertion (A) and reason (R) are true but reason (R) is not the correct explanation of assertion (A).
 - Assertion (A) is true but reason (R) is false.
 - Assertion (A) is false but reason (R) is true.

SECTION-B

Question no. 21 to 26 are very short answer questions.

21. Why do the articles made of aluminium not corrode?
- or**
- $\text{Fe} + \text{CuSO}_4 \rightarrow \text{FeSO}_4 + \text{Cu}$
 - $\text{Cu} + \text{FeSO}_4 \rightarrow \text{CuSO}_4 + \text{Fe}$
- Which of the above two reactions will take place and why ?
22. Stomata of desert plants remain closed during day time. How do they take up carbon dioxide and perform photosynthesis ?
23. Which is the largest digestive gland present in human body ? What is the name and function of its secretion?
24. What are the end products formed during fermentation in yeast ? Under what condition a similar process takes place in our body that leads to muscle cramps ?
25. Why there is no dispersion of light refracted through a rectangular glass slab.
- or**
- What is meant by near point and far point of an eye? State their values of the normal human eye.
26. In a food chain comprising frogs, insects, birds and grass, which one of the organisms is likely to have maximum concentration of harmful non-biodegradable chemicals in its body ?

Click the Following Button to See the Free MS/Solutions

SOLUTIONS

SECTION-C

Question no. 27 to 33 are short answer questions.

27. Name the type of chemical reaction represented by the following equations :

- (i) $\text{CaCO}_3(\text{s}) \xrightarrow{\text{Heat}} \text{CaO}(\text{s}) + \text{CO}_2(\text{g})$
 (ii) $\text{CaO}(\text{s}) + \text{H}_2\text{O}(\text{l}) \rightarrow \text{Ca}(\text{OH})_2(\text{aq})$
 (iii) $\text{Zn}(\text{s}) + \text{H}_2\text{SO}_4(\text{aq}) \rightarrow \text{ZnSO}_4(\text{aq}) + \text{H}_2(\text{g})$

28. (a) A non-metal X exists in two different forms Y and Z . Y is the hardest natural substance whereas Z is a good conductor of electricity. Identify X , Y , Z .
 (b) An element X on reaction with oxygen forms an oxide XO_2 . The oxide when dissolved in water turns blue litmus red. State whether element X is a metal or non-metal.
 (c) Name the metal which is alloyed with copper to make bronze.

29. Explain the process of assimilation of proteins in human digestive system.

or

Write three events which occur during the process of photosynthesis.

30. An object 4 cm in height is placed at 15 cm in front of a concave mirror of focal length 10 cm. At what distance from the mirror should a screen be placed to obtain a sharp image of the object. Calculate the height of the image.

31. (a) Name the kind of lens that can form;
 (i) an inverted magnified image.
 (ii) an erect diminished image.
 Draw ray diagrams to illustrate your answer in each case.
 (b) Draw a ray diagram to show the image formed of an object placed between f and $2f$ distances from a convex lens.

32. What would be the reading of ammeter and voltmeter in the given circuit?

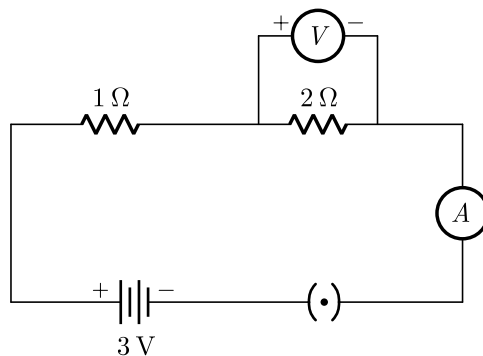

or

Two resistors with resistances $10\ \Omega$ and $15\ \Omega$ are to be connected to emf $12\ \text{V}$ so as to obtain : (i) minimum current (ii) maximum current. How will you connect the resistance in each case ? Calculate the strength of the total current in the circuit in the two cases.

Continue on next page.....

Click the Following Button to See the Free MS/Solutions

SOLUTIONS

33. It is said that, there is a need to put a complete ban on the products containing aerosols. What are aerosols ? Why is there a demand to put a ban on them.

SECTION-D

Question no. 34 to 36 are Long answer questions.

34. (a) Draw the structure of ethanoic acid.
 (b) Name the compound formed when ethanol is heated with ethanoic acid in the presence of conc. H_2SO_4 .
 (c) Complete the following equations :

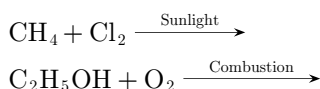

or

- (a) A compound X having formula $\text{C}_2\text{H}_4\text{O}_2$ when treated with ethanol and a few drops of conc. H_2SO_4 forms a sweet smelling substance Y. Name X and Y. Write the equation of the reaction leading to the formation of Y from X. What is the function of conc. H_2SO_4 in the above reaction?
 (b) Why do soaps form scum instead of lather in hard water ?
35. (a) Differentiate between pollen grain and ovule.
 (b) State in brief the functions of the following parts of the human female reproductive system :
 (i) Ovary
 (ii) Fallopian tube
 (iii) Uterus

or

- (a) What is variation? How is variation created in a population? How does the creation of variation in a species promote survival?
 (b) Explain how, offspring and parents of organisms reproducing sexually have the same number of chromosomes.
36. An electric lamp of resistance $20\ \Omega$ and a conductor of resistance $4\ \Omega$ are connected to a 6 V battery as shown in the circuit. Calculate :

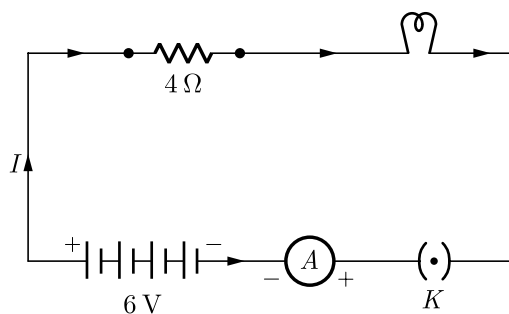

- (a) the total resistance of the circuit,
 (b) the current through the circuit,
 (c) the potential difference across the (i) electric lamp and (ii) conductor, and
 (d) power of the lamp.

Click the Following Button to See the Free MS/Solutions

SOLUTIONS

SECTION-E

Question no. 37 to 39 are case-based/data -based questions with 2 to 3 short sub-parts. Internal choice is provided in one of these sub-parts.

37. The earth's crust is the major source of metals-seawater contains some soluble salts such as sodium chloride, magnesium chloride, etc. The elements or compounds, which occur naturally in the earth's crust are known as minerals. At some places, minerals contain a very high percentage of a particular metal and the metal can be profitably extracted from it. These minerals are called ores.

- (i) Name the chief ore of mercury and zinc.
- (ii) Write equations for the extraction of copper from its sulphide ore.

or

- (ii) Define the process used to convert carbonate ores into metal oxide.

38. Chronic Kidney Disease (CKD) is a condition characterized by a gradual loss of kidney function over time. CKD is also known as chronic renal disease. With increasing life expectancy and prevalence of life style diseases, US has seen a 30% increase in prevalence of Chronic Kidney Disease (CKD) in the last decade. Unfortunately, from India there is no longitudinal study and limited data on the prevalence of CKD.

In western countries, diabetes and hypertension account for over 2/3rd of the cases of CKD. In India too, diabetes and hypertension today account for 40-60% cases of CKD. As per recent Indian Council of Medical Research data, prevalence of diabetes in Indian adult population has risen to 7.1%, (varying from 5.8% in Jharkhand to 13.5% in Chandigarh) and in urban population (over the age of 40 years) the prevalence is as high as 28%. Likewise, the reported prevalence of hypertension in the adult population today is 17% (14.8% from rural and 21.4% from urban belt). A similar prevalence of 17.4% has been reported by Panesar et al. (in the age group of 20-59 years) even from slum-resettlement colony of Delhi. With rising prevalence of these diseases in India, prevalence of CKD is expected to rise and obviously, this is the key target population to address.

A study published in this issue is from a rural belt of Karnataka. The population had a mean age of 39.88 ± 15.87 years with 3.82% prevalence of diabetes and 33.62% of hypertension. Authors found 6.3% prevalence of CKD stage 3; which is the highest reported till date by any Indian worker. It is disturbing to note, the high prevalence of hypertension in a rural setting where over 75% population had normal or low body mass index. In comparison to most other published studies from India, the present study population is younger and even the prevalence of diabetes is low but surprisingly despite that prevalence of stage 3 CKD is reported to be higher (6.3%). It is disturbing to see the rising prevalence of hypertension and CKD in rural belts. Possibly, with shifting population the difference between urban and rural areas is getting blurred. Undoubtedly, we need more Indian data to validate these findings.

- (i) What is CKD ?
- (ii) What are the major causes of CKD ?
- (iii) In which segment of society is CKD more prevalent?

or

- (iv) What is the highest percentage of CKD reported?

Continue on next page.....

Click the Following Button to See the Free MS/Solutions

SOLUTIONS

39. A concave lens is thick at the edges and thin at the centre, while a convex lens is thick at the centre and thin at the edges. We can distinguish between a concave lens and a convex lens without touching them. For this keep a book close to a lens and observe the image of the text of the book through the lens. If the letters appear enlarged, then it is a convex lens and if the letters appear diminished then it is a concave lens.



Convex

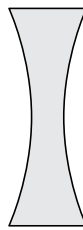

Convex

Convex lens converges light rays and hence known as converging lens. Similarly, concave lens diverges light rays and is known as diverging lens. Linear magnification produced by a lens is equal to the ratio of the image distance to the object distance. Power of a lens is defined as the reciprocal of its focal length.

- (i) What type of image is always made by a concave lens ?
- (ii) If magnification produced by a spherical lens is $+0.75$, then what is the nature of the lens ?
- (iii) What is the power of a convex lens with focal length 80 cm ?

or

- (iii) What kind of lens is present in human eye ?

□□□□□□

DOWNLOAD INDIA'S BEST STUDY MOBILE APP

- 30 Sample Paper with Solutions
- Chapterwise Question Bank of All Subject
- Previous 15 Years Solved Papers
- NCERT Solutions
- Case Study Questions with full Solutions
- **Word File of Material for Teachers**

Search by **NODIA** on Play Store to Download App

Add 89056 29969 in Your Class Whatsapp Group to Get Link

Click the Following Button to See the Free MS/Solutions

SOLUTIONS

Sample Paper 15

Class X 2023-24

Science (086)

Time: 3 Hours

Max. Marks: 80

General Instructions:

1. This question paper consists of 39 questions in 5 sections.
 2. All questions are compulsory. However, an internal choice is provided in some questions. A student is expected to attempt only one of these questions.
 3. Section A consists of 20 Objective Type questions carrying 1 mark each.
 4. Section B consists of 6 Very Short questions carrying 02 marks each. Answers to these questions should be in the range of 30 to 50 words.
 5. Section C consists of 7 Short Answer type questions carrying 03 marks each. Answers to these questions should be in the range of 50 to 80 words.
 6. Section D consists of 3 Long Answer type questions carrying 05 marks each. Answer to these questions should be in the range of 80 to 120 words.
 7. Section E consists of 3 source-based/case-based units of assessment of 04 marks each with sub-parts.
-

SECTION-A

Select and write one most appropriate option out of the four options given for each of the questions 1 – 20.

1. Length of pollen tube depends on the distance between

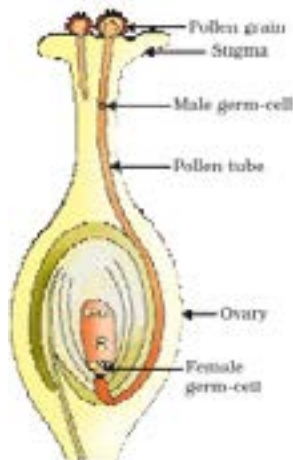

- (a) pollen grain and upper surface of stigma
- (b) pollen grain on upper surface of stigma and ovule
- (c) pollen grain in anther and upper surface of stigma
- (d) upper surface of stigma and lower part of style

Continue on next page.....

Click the Following Button to See the Free MS/Solutions

SOLUTIONS

2. In the following practical set which of the following gas is emitted?

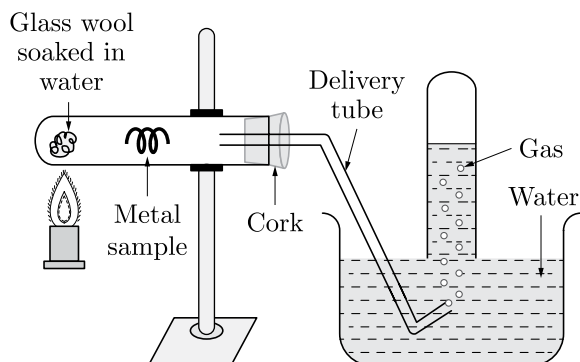

- (a) Hydrogen
 (b) Carbon monoxide
 (c) Carbon dioxide
 (d) Nitrogen
3. Metal reacts with water and produce a metal oxide and hydrogen gas. Metal oxides that are soluble in water dissolve in it to further form metal hydroxide. But all metals do not react with water. Which of the following statement is correct regarding to physical changes?
- (a) In physical change, new substance is formed.
 (b) In physical change, no new substance is formed.
 (c) In physical change, chemical composition of substance is changed.
 (d) None of these
4. To protect tooth decay we are advised to brush our teeth regularly. The nature of the toothpaste commonly used is
- (a) acidic
 (b) neutral
 (c) basic
 (d) corrosive
5. AB is a current carrying conductor in the plane of the paper as shown in figure. The directions of magnetic fields produced by it at points P and Q (Given $r_1 > r_2$, where will the strength of the magnetic field be larger)

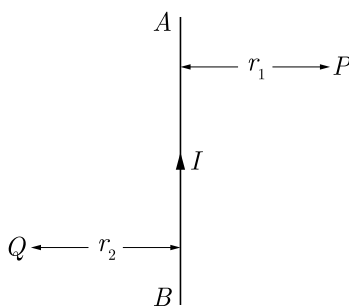

- (a) Inwards, Outwards
 (b) Outwards, Inwards
 (c) Inwards, Inwards,
 (d) Outwards, Outwards

Click the Following Button to See the Free MS/Solutions

SOLUTIONS

6. Tricuspid valve is present in ?
 (a) Right atrium and right ventricle
 (b) Left atria and left ventricle
 (c) Wall of atrium
 (d) Wall of ventricle
7. Which one reaction shows the property of double displacement reaction?
 (a) $\text{CuSO}_4 + \text{Zn} \longrightarrow \text{ZnSO}_4 + \text{Cu}$
 (b) $\text{Cu} + 2\text{AgNO}_3 \longrightarrow \text{Cu}(\text{NO}_3)_2 + 2\text{Ag}$
 (c) $\text{NaOH} + \text{HCl} \longrightarrow \text{NaCl} + \text{H}_2\text{O}$
 (d) None of these
8. Match the chemical substances given in column (A) with their appropriate application given in column (B)

	Column (A)		Column (B)
A.	Bleaching powder	(i)	Preparation of glass
B.	Baking soda	(ii)	Production of H_2 and Cl_2
C.	Washing soda	(iii)	Decolorization
D.	Sodium chloride	(iv)	Antacid

- (a) A- (ii), B- (i), C- (iv), D- (iii)
 (b) A- (iii), B- (ii), C- (iv), D- (i)
 (c) A- (iii), B- (iv), C- (i), D- (ii)
 (d) A- (ii), B- (iv), C- (i), D- (iii)
9. Massive amounts of gaseous exchange takes place in the leaves through stomata for the purpose of
 (a) Photosynthesis
 (b) Carrying carbon dioxide
 (c) Reduction of carbon dioxide
 (d) Generation of carbohydrates
10. Ethanol reacts with sodium and forms two products. These are

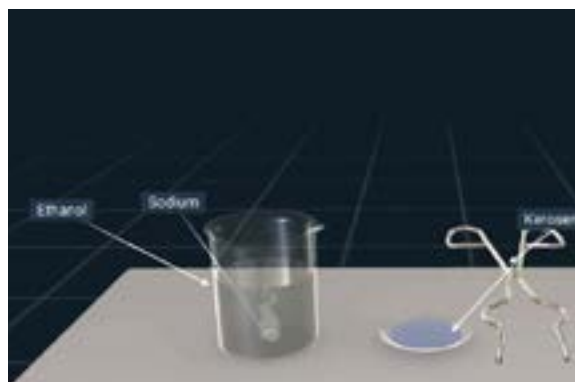

- (a) sodium ethanoate and hydrogen
 (b) sodium ethanoate and oxygen
 (c) sodium ethoxide and hydrogen
 (d) sodium ethoxide and oxygen

Click the Following Button to See the Free MS/Solutions

SOLUTIONS

11. The current flowing through a resistor connected in an electrical circuit and the potential difference developed across its ends are shown in the given ammeter and voltmeter. The voltage and the current across the given resistor are respectively:

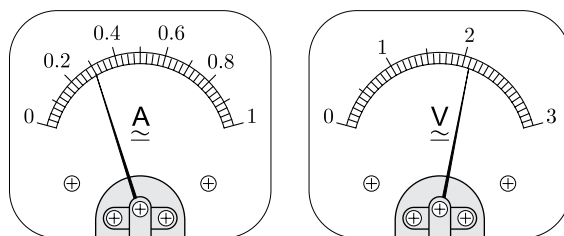

- (a) 2.1 V, 0.3 A
 (b) 3.1 V, 1.3 A
 (c) 1.1 V, 0.6 A
 (d) 0.1 V, 0.2 A
12. Which of the following statements are true about the brain ?
- The main thinking part of brain is hind brain.
 - Centres of hearing, smell, memory, sight etc. are located in fore brain.
 - Involuntary actions like salivation, vomiting, blood pressure are controlled by the medulla in the hind brain.
 - Cerebellum does not control posture and balance of the body
- (a) (i) and (ii)
 (b) (i), (ii) and (iii)
 (c) (ii) and (iii)
 (d) (iii) and (iv)
13. Which of the following are combination reaction?
- $2\text{KClO}_3 \xrightarrow{\text{Heat}} 2\text{KCl} + 3\text{O}_2$
 - $\text{MgO} + \text{H}_2\text{O} \longrightarrow \text{Mg}(\text{OH})_2$
 - $4\text{Al} + 3\text{O}_2 \longrightarrow 2\text{Al}_2\text{O}_3$
 - $\text{Zn} + \text{FeSO}_4 \longrightarrow \text{ZnSO}_4 + \text{Fe}$
- (a) 1 and 3
 (b) 3 and 4
 (c) 2 and 4
 (d) 2 and 3
14. Which blood vessels have high blood pressure and what they have to withstand this high pressure?

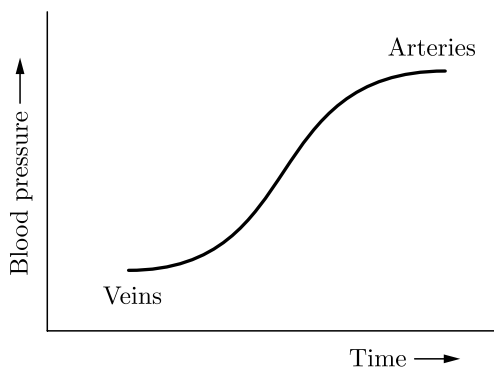

Continue on next page.....

Click the Following Button to See the Free MS/Solutions

SOLUTIONS

- (a) Both arteries and veins have same pressure of blood and they are thick walled vessels.
 (b) Arteries have high blood pressure and they have elastic and thick walls to withstand this high pressure.
 (c) Veins have high blood pressure and they have to valves to withstand this high pressure.
 (d) None of the above.
15. The pattern of the magnetic field produced by the straight current carrying conducting wire is
 (a) in the direction opposite to the current
 (b) in the direction parallel to the wire
 (c) circular around the wire
 (d) in the same direction of current
16. In the given circuit, PQR and PSR are semicircles. What will be the magnetic field at the center A of the circular loop ?

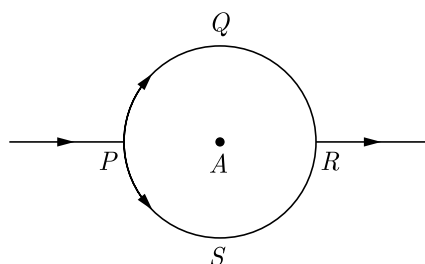

- (a) Zero
 (b) $2\pi r\mu_0$
 (c) 1
 (d) $\mu_0 \frac{B}{2\pi r}$

Question no. 17 to 20 are Assertion-Reasoning based questions.

17. **Assertion :** During digestion, carbohydrates are broken down to form glucose.
Reason : Glucose is necessary for breathing.
 (a) Both Assertion and Reason are True and Reason is the correct explanation of the Assertion.
 (b) Both Assertion and Reason are True but Reason is not the Correct explanation of the Assertion.
 (c) Assertion is True but the Reason is False.
 (d) Both Assertion and Reason are False.
18. **Assertion :** In humans, males play an important role in determining the sex of the child.
Reason : Males have two X chromosomes.
 (a) Both assertion (A) and reason (R) are true and reason (R) is the correct explanation of assertion (A).
 (b) Both assertion (A) and reason (R) are true but reason (R) is not the correct explanation of assertion (A).
 (c) Assertion (A) is true but reason (R) is false.
 (d) Assertion (A) is false but reason (R) is true.
19. **Assertion :** Failure of the kidneys leads to death of the person and there is no way he can survive.
Reason : Transplant of kidneys in humans is not possible.
 (a) Both Assertion and Reason are true and Reason is the correct explanation of Assertion.
 (b) Both Assertion and Reason are true but Reason is not the correct explanation of Assertion.
 (c) Assertion is true but Reason is false.
 (d) Both Assertion and Reason are false.

Click the Following Button to See the Free MS/Solutions

SOLUTIONS

20. **Assertion :** There is no change in the energy of a charged particle moving in a magnetic field although a magnetic force is acting on it.
Reason : Work done by centripetal force is always zero.
- (a) Both assertion (A) and reason (R) are true and reason (R) is the correct explanation of assertion (A).
 - (b) Both assertion (A) and reason (R) are true but reason (R) is not the correct explanation of assertion (A).
 - (c) Assertion (A) is true but reason (R) is false.
 - (d) Assertion (A) is false but reason (R) is true.

SECTION-B

Question no. 21 to 26 are very short answer questions.

21. Give reasons for the following :
- (a) Sodium chloride has a high melting point.
 - (b) Non-metals do not displace hydrogen from dilute acids.

or

A substance X , which is an oxide of a metal is used intensively in the cement industry. This element is present in bones also. On treatment with water it forms a solution which turns red litmus blue. Identify X and also write the chemical reactions involved.

22. What is parasitism ? Give two examples of parasites one from animals and one from plants.
23. What is phloem ? Name its two main components (elements) which help in the conduction of food.
24. Name the parts of a nephron in their proper sequence starting from the point of entry of blood into it upto the point of pouring out of the urine from the nephron.
25. Why does it take some time to see the objects in a dim-lit room when we enter the room from bright sunlight outside ?

or

Give reason :

- (a) Danger signals are red.
 - (b) We cannot see an object clearly if it is placed very close to the eyes.
26. Consider the food chain :

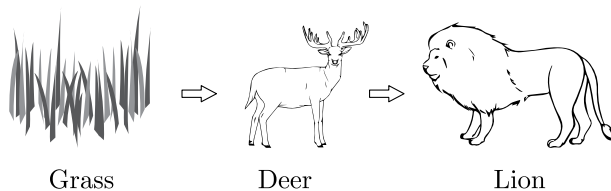

What will happen if lions are removed from the above food chain ?

Click the Following Button to See the Free MS/Solutions

SOLUTIONS

SECTION-C

Question no. 27 to 33 are short answer questions.

27. Give chemical explanation for evolution and absorption of heat in a chemical reaction.
28. (a) Why metals are not found in their free state generally ?
(b) If a strip of aluminium with scratched clean surface is dipped into an aqueous solution of copper sulphate for little time, the surface of the strip becomes brownish. What is the reason for this ? Write the balanced chemical equation for the reaction.
29. Define pollination. Explain the different types of pollination.' List two agents of pollination? How does suitable pollination lead to fertilization?

or

A student wants to germinate dicot seeds. Write the four steps in correct sequence that will help him to perform the experiment in the right way.

30. (a) State laws of refraction.
(b) A ray of light is incident normally to the surface of a glass slab placed in air. Find the angle of incidence and angle of refraction in this case.
31. A 3 cm tall object is placed 18 cm in front of a concave mirror of focal length 12 cm. At what distance from the mirror should a screen be placed to see a sharp image of the object on the screen. Also calculate the height of the image formed.
32. Demonstrate that due to motion of a magnet near a solenoid coil an induced current is set up in the coil.

or

The flow of current in a circular loop of wire creates a magnetic field at its center. How may existence of this field be detected ? State the rule which helps to predict the direction of this magnetic field.

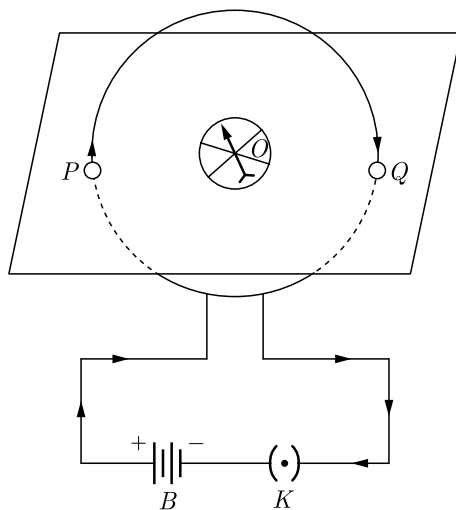

33. Give reason to justify the following :
- The existence of decomposer is essential in a biosphere.
 - Flow of energy in a food chain is unidirectional.

Click the Following Button to See the Free MS/Solutions

SOLUTIONS

SECTION-D

Question no. 34 to 36 are Long answer questions.

34. The formula of four organic compounds are given below:

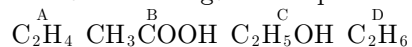

- (i) Which one of these compounds *A*, *B*, *C* or *D* is a saturated hydrocarbon?
- (ii) Identify the organic acid and give its structural formula.
- (iii) Which of the above compounds when heated at 443K in the presence of concentrated H_2SO_4 forms ethene as the major product? What is the role played by concentrated H_2SO_4 in this reaction? Also write the chemical equation involved.
- (iv) Give a chemical equation when *B* and *C* react with each other in presence of concentrated H_2SO_4 . Name the major product formed and mention one of its important use.

or

- (a) Carry out the following conversions giving complete conditions for the reaction to take place in each case :
 - (i) Ethanoic acid from Ethanol
 - (ii) Ethane from Ethene
 - (iii) Ester from Ethanoic acid and ethanol
 Also state the names given to all the above conversions.
- (b) Detergents are preferred over soaps. Why? (Give one reason)

35. (a) Which device prevents implantation by irritating the lining of uterus?
- (b) What could be the possible reason for declining female : male sex ratio in our country? Suggest two measures to achieve 1:1 ratio.
- (c) Name those parts of a flower which serve the same function as the following do in animals :
 - (i) Testis
 - (ii) Ovary
 - (iii) Eggs
 - (iv) Sperms

or

- (a) With the help of diagram show asexual reproduction in Rhizopus.
- (b) How is this method advantageous for Rhizopus?
- (c) How is mode of reproduction in unicellular organisms differ from multicellular organisms?

36. In our daily life we use two types of electric current whose current time graphs are given below :

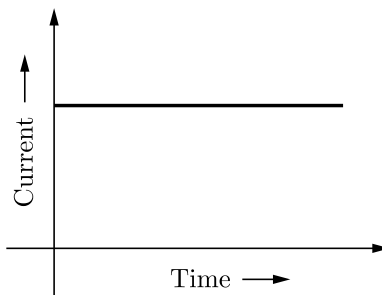

Continue on next page.....

Click the Following Button to See the Free MS/Solutions

SOLUTIONS

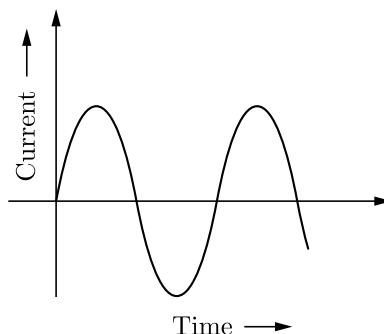

- (i) Name the type of current in two cases.
- (ii) Identify any one source for each type of current.
- (iii) What is the frequency of current in case (b) in our country ?
- (iv) On the basis of these graphs list two differences between the two currents.
- (v) Out of the two which one is used in transmitting electric power over long distances and why ?

SECTION-E

Question no. 37 to 39 are case-based/data-based questions with 2 to 3 short sub-parts. Internal choice is provided in one of these sub-parts.

37. Electronic configuration of some of the elements are given :

Type of element	Element	Atomic number	Number of electrons in shell
Metals	Sodium (Na)	11	2 8 1
	Magnesium (Mg)	12	2 8 2
	Aluminium (Al)	13	2 8 3
Non-metals	Oxygen (O)	8	2 6
	Sulphur (S)	16	2 8 6
	Chlorine (Cl)	17	2 8 7

- (i) State one physical property to distinguish between metals and non-metals.
- (ii) What is the nature of the bond formed when magnesium reacts with chlorine? Write the formula of the compound.

or

- (ii) What is common between oxygen and sulphur? Draw the electron dot structure of O₂ molecule.

38. Plant hormones affect gene expression and transcription levels, cellular division and growth. They are naturally produced within plants, but very similar chemicals are produced by fungi and bacteria that can also affect plant growth. A large number of related chemical compounds are synthesized by humans. They are used to regulate the growth of cultivated plants, weeds and in vitro-grown plants and plant cells; these man-made compounds are called plant growth regulators or PGRs for short. Plant hormones are not nutrients, but chemicals that in small amounts promote and influence the growth, development and differentiation of cells and tissues. The biosynthesis of plant hormones within plant tissues is often diffused and not always localized. Plants lack glands to produce and store hormones, because, unlike animals which have two circulatory systems (lymphatic and cardiovascular) powered by a heart that moves fluids around the body. Plants use more passive means to move chemicals around their bodies. Plants utilize simple chemicals as hormones, which move more easily through their tissues. They are often produced and used on a local basis within the plant body. Plant cells produce hormones that affect different regions of the cell producing the hormone.

Different hormones can be sorted into different classes, depending on their chemical structures. Within each class of hormone the exact structures vary, but they have similar physiological effects. Initial research into plant hormones identified five major classes : abscisic acid, auxin, cytokinins, ethylene and gibberellins. This list was later expanded and brassinosteroids, jasmonates, salicylic acid and strigolactones are now considered as major plant hormones.

Click the Following Button to See the Free MS/Solutions

SOLUTIONS



- (i) What are the factors affected by the plant hormones ?
- (ii) What does PGR stands for ?
- (iii) Which class does plant hormones fall into ?

or

- (iv) What were the five major plant hormones discovered in the initial research ?

39. A person is suffering from hypermetropia (long sightedness). It is a defect in which a human eye can see far off object clearly, but is unable to see nearby object distinctly. The near point of the person is 1.5 m. Assume that the near point of the normal eye is 25 cm.

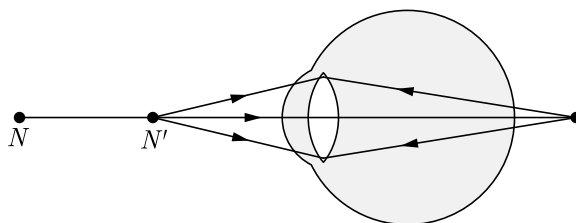

- (i) What type of lens should be used in his spectacles?
- (ii) What should be the focal length of the lens he used ?
- (iii) What will be the power of the lens ?

or

- (iv) Write one possible cause of this defect.

□□□□□□

DOWNLOAD INDIA'S BEST STUDY MOBILE APP

- 30 Sample Paper with Solutions
- Chapterwise Question Bank of All Subject
- Previous 15 Years Solved Papers
- NCERT Solutions
- Case Study Questions with full Solutions
- **Word File of Material for Teachers**

Search by **NODIA** on Play Store to Download App
Add 89056 29969 in Your Class Whatsapp Group to Get Link

Click the Following Button to See the Free MS/Solutions

SOLUTIONS

Sample Paper 16

Class X 2023-24

Science (086)

Time: 3 Hours

Max. Marks: 80

General Instructions:

1. This question paper consists of 39 questions in 5 sections.
 2. All questions are compulsory. However, an internal choice is provided in some questions. A student is expected to attempt only one of these questions.
 3. Section A consists of 20 Objective Type questions carrying 1 mark each.
 4. Section B consists of 6 Very Short questions carrying 02 marks each. Answers to these questions should be in the range of 30 to 50 words.
 5. Section C consists of 7 Short Answer type questions carrying 03 marks each. Answers to these questions should be in the range of 50 to 80 words.
 6. Section D consists of 3 Long Answer type questions carrying 05 marks each. Answer to these questions should be in the range of 80 to 120 words.
 7. Section E consists of 3 source-based/case-based units of assessment of 04 marks each with sub-parts.
-

SECTION-A

Select and write one most appropriate option out of the four options given for each of the questions 1 – 20.

1. Which arrangement of 3Ω resistors will give a total resistance of 7Ω ?

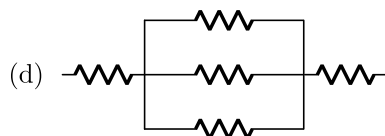
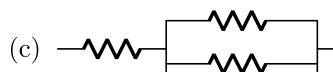
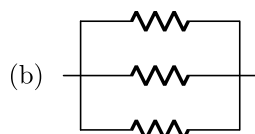

2. Which among the following is/are double displacement reaction(s)?

- (i) $\text{Pb} + \text{CuCl}_2 \rightarrow \text{PbCl}_2 + \text{Cu}$
- (ii) $\text{Na}_2\text{SO}_4 + \text{BaCl}_2 \rightarrow \text{BaSO}_4 + 2\text{NaCl}$
- (iii) $\text{C} + \text{O}_2 \rightarrow \text{CO}_2$
- (iv) $\text{CH}_4 + 2\text{O}_2 \rightarrow \text{CO}_2 + 2\text{H}_2\text{O}$

- (a) (i) and (ii)
- (b) (i) and (iv)
- (c) (iii) and (iv)
- (d) only (ii)

Continue on next page.....

Click the Following Button to See the Free MS/Solutions

SOLUTIONS

3. Identify the correct order of reactivity of metals among the following:
- $\text{Fe} < \text{Zn} < \text{Cu} < \text{Na} < \text{Al}$
 - $\text{Cu} < \text{Fe} < \text{Zn} < \text{Al} < \text{Na}$
 - $\text{Cu} < \text{Zn} < \text{Al} < \text{Na} < \text{Fe}$
 - $\text{Zn} < \text{Cu} < \text{Fe} < \text{Al} < \text{Na}$
4. An aqueous solution A turns phenolphthalein solution pink. On addition of an aqueous solution B to A, the pink colour disappears. Which of the following statement is true for solution A and B?
- A is strongly acidic and B is a weak acid.
 - A is strongly basic and B is a weak base.
 - A has pH less than 7 and B has pH greater than 7.
 - A has pH greater than 7 and B has pH less than 7.
5. Identify labels p, q and r and select the correct option.

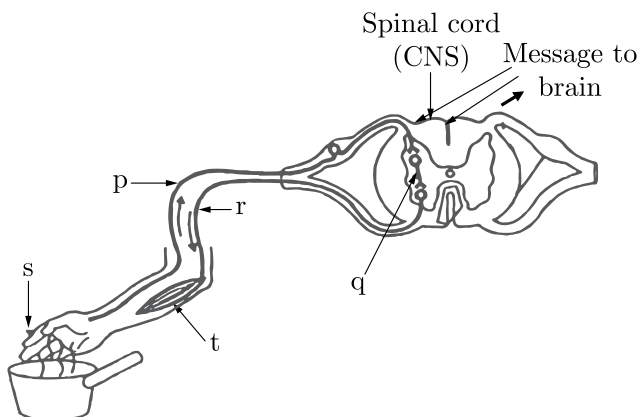

	p	q	r
(a)	Motor neuron	Sensory neuron	Relay neuron
(b)	Sensory neuron	Motor neuron	Relay neuron
(c)	Relay neuron	Motor neuron	Sensory neuron
(d)	Sensory neuron	Relay neuron	Motor neuron

Continue on next page.....

Click the Following Button to See the Free MS/Solutions

SOLUTIONS

6. When lead nitrate crystals are heated as shown in the figure:

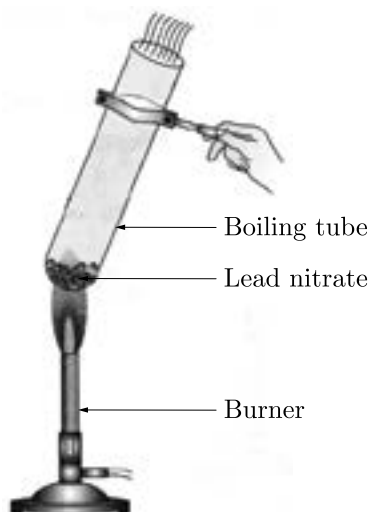

- (a) a brown gas is evolved and a white residue is left behind
(b) a colourless gas is evolved and a yellow residue is left behind
(c) a brown gas is evolved and a yellow residue is left behind.
(d) a greenish yellow gas is evolved and a brown residue is left behind
7. The image shows the division in Spirogyra.

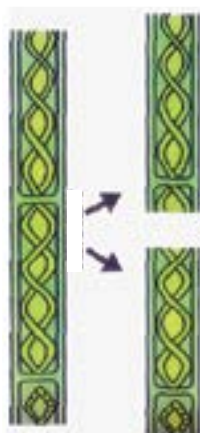

What can be concluded about the Spirogyra from this division?

- (a) It is a unicellular organism that gives rise to two new equal sized individuals.
(b) It is a multicellular organism gives rise to two new equal sized individuals.
(c) It is a multicellular organism that breaks into pieces that grows into new individuals.
(d) It is a unicellular organism that breaks into pieces that grows into new individuals.

Continue on next page.....

Click the Following Button to See the Free MS/Solutions

SOLUTIONS

8. The factors on which magnetic field strength produced by current carrying solenoid depends are:
- number of turns
 - magnitude of current
 - All of the above
 - nature of core material
9. Three resistances of 2, 3 and 5Ω are connected in parallel to a 10 V battery of negligible internal resistance. The potential difference across the 3Ω resistance will be:
- 3 V
 - 2 V
 - 10 V
 - 5 V
10. A student places some iron filings around a magnet. The iron filings arrange themselves as shown in image:

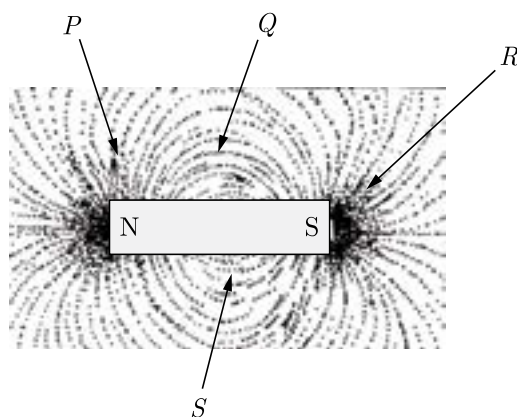

The student labelled four different regions around the magnet. Where would the magnetic effect be the strongest?

- Q*
 - P*
 - S*
 - R*
11. Study the experimental set up shown in given figure and choose the correct option from the following:

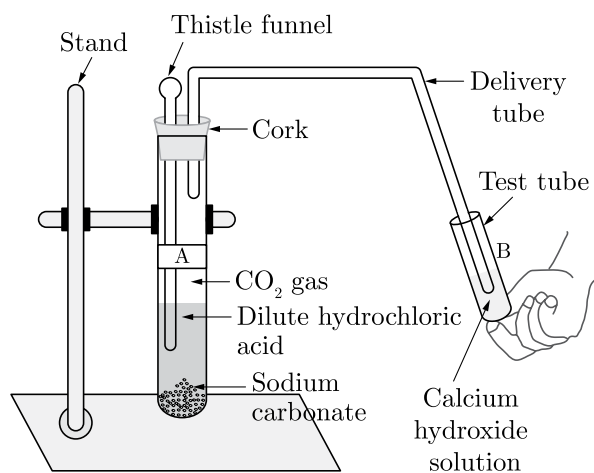

Continue on next page.....

Click the Following Button to See the Free MS/Solutions

SOLUTIONS

	P	Q	Change observed in calcium hydroxide solution
a.	K_2CO_3	Cl_2	No change
b.	$KHCO_3$	CO_2	No change
c.	$KHCO_3$	H_2	Turns milky
d.	K_2CO_3	CO_2	Turns milky

12. Two pink coloured flowers on crossing resulted in 1 red, 2 pink and 1 white flower progeny. The nature of the cross will be :
- self pollination
 - double fertilisation
 - no fertilisation
 - cross fertilisation
13. Identify the option that indicates the correct enzyme that is secreted in location (i), (ii) and (iii).
- (i)-amylase, (ii)-pepsin, (iii)-trypsin
 - (i)-lipase, (ii)-trypsin, (iii)-pepsin
 - (i)-permease, (ii)-carboxylase, (iii)-oxidase
 - (i)-trypsin, (ii)-amylase, (iii)-carboxylase
14. Which one of the following conditions is true for the state of stomata of a green leaf shown in the given diagram?

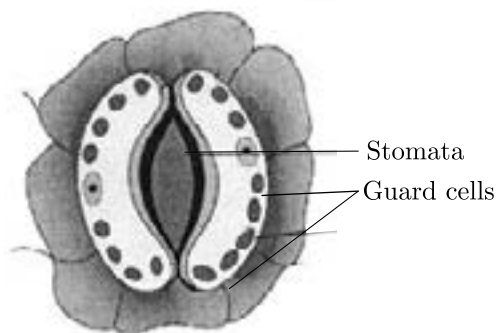

- Gaseous exchange is occurring in large amount
 - Large amount of water flows into the guard cells
 - Large amount of sugar collects in the guard cells
 - Large amount of water flows out from the guard cells
15. Study the following table and choose the correct option.

	Salt	Parent Acid	Parent base	Nature of salt
a.	Sodium Chloride	HCl	NaOH	Basic
b.	Sodium Carbonate	H_2CO_3	NaOH	Neutral
c.	Sodium Sulphate	H_2SO_4	NaOH	Acidic
d.	Sodium Acetate	CH_3COOH	NaOH	Basic

Click the Following Button to See the Free MS/Solutions

SOLUTIONS

16. Number of electrons shared between carbon-carbon atoms in ethene is:

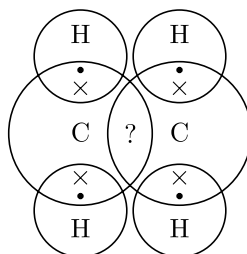

- (a) 4 (b) 2
(c) 8 (d) 6

Question no. 17 to 20 are Assertion-Reasoning based questions.

17. **Assertion (A):** The sex of a child in human beings will be determined by the type of chromosome he/she inherits from the father.

Reason (R): A child who inherits 'X' chromosome from his father would be a girl (XX), while a child who inherits a 'Y' chromosome from the father would be a boy (XY).

- (a) Both Assertion (A) and Reason (R) are true and Reason (R) is the correct explanation of Assertion (A).
(b) Both Assertion (A) and Reason (R) are true but Reason (R) is not a correct explanation of Assertion (A).
(c) Assertion (A) is true but Reason (R) is false.
(d) Assertion (A) is false but Reason (R) is true.
18. **Assertion (A):** In Fleming's left-hand rule, the direction of magnetic field, force and current are mutually perpendicular.
Reason (R): Fleming's left-hand rule is applied to measure the induced current.
- (a) Both Assertion (A) and Reason (R) are true and Reason (R) is the correct explanation of Assertion (A).
(b) Both Assertion (A) and Reason (R) are true but Reason (R) is not a correct explanation of Assertion (A).
(c) Assertion (A) is true but Reason (R) is false.
(d) Assertion (A) is false but Reason (R) is true.

19. **Assertion (A):** Resins and gums are stored in old xylem tissue in plants.

Reason (R): Resins and gums facilitate transport of water molecules.

- (a) Both Assertion (A) and Reason (R) are true and Reason (R) is the correct explanation of Assertion (A).
(b) Both Assertion (A) and Reason (R) are true but Reason (R) is not a correct explanation of Assertion (A).
(c) Assertion (A) is true but Reason (R) is false.
(d) Assertion (A) is false but Reason (R) is true.

20. **Assertion (A):** The following chemical equation,

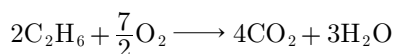

is a balanced chemical equation.

Reason (R): In a balanced chemical equation, the total number of atoms of each element are equal on both sides of the equation.

- (a) Both Assertion (A) and Reason (R) are true and Reason (R) is the correct explanation of Assertion (A).
(b) Both Assertion (A) and Reason (R) are true but Reason (R) is not a correct explanation of Assertion (A).
(c) Assertion (A) is true but Reason (R) is false.
(d) Assertion (A) is false but Reason (R) is true.

Click the Following Button to See the Free MS/Solutions

SOLUTIONS

SECTION-B

Question no. 21 to 26 are very short answer questions.

21. Why does absorption of digested food occur mainly in the small intestine?
22. Identify the oxidising agent in the following reactions:
 (i) $\text{Pb}_3\text{O}_4 + 8\text{HCl} \longrightarrow 3\text{PbCl}_2 + \text{Cl}_2 + 4\text{H}_2\text{O}$
 (ii) $2\text{Mg} + \text{O}_2 \longrightarrow 2\text{MgO}$

or

Complete the following table:

	Plaster of Paris	Bleaching Powder
Chemical equation for its preparation	(i)	(ii)
Use	(iii)	(iv)

23. State with reason any two possible consequences of the elimination of decomposers from the earth.
24. List in tabular form two differences between reflex action and walking.
25. Name the four parts labelled as a, b, c and d in given diagram and write their functions.

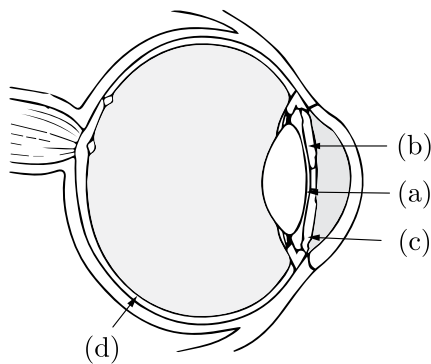

or

List two causes of presbyopia. Draw labelled diagram of a lens used for the correction of this defect of vision.

26. (i) Write a balanced equation for photosynthesis.
 (ii) Which digestive secretion does not contain any enzyme but is important? Discuss.

Click the Following Button to See the Free MS/Solutions

SOLUTIONS

SECTION-C

Question no. 27 to 33 are short answer questions.

27. Name the type of mirror which facilitates

- (i) Shaving,
- (ii) Observing large images of the teeth of a patient, and
- (iii) Observing the rear view in vehicles.

Give reason to justify your answer in each case.

28. The magnification of an image formed by a lens is -1 . If the distance of the image from the optical centre of the lens is 25 cm, where is the object placed? Find the nature and focal length of the lens. If the object is displaced 15 cm towards the optical centre of the lens, where would the image be formed? Draw a ray diagram to justify your answer.

29. What is transpiration? List its two functions.

or

List four functions of the human heart. Why is double circulation necessary in the human body?

30. A student takes three beakers A, B and C filled with aqueous solutions of glucose, alcohol and hydrochloric acid respectively as shown in the following figures :

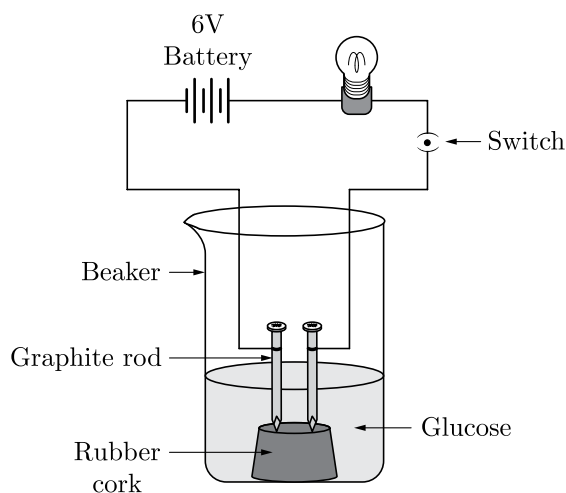

Continue on next page.....

Click the Following Button to See the Free MS/Solutions

SOLUTIONS

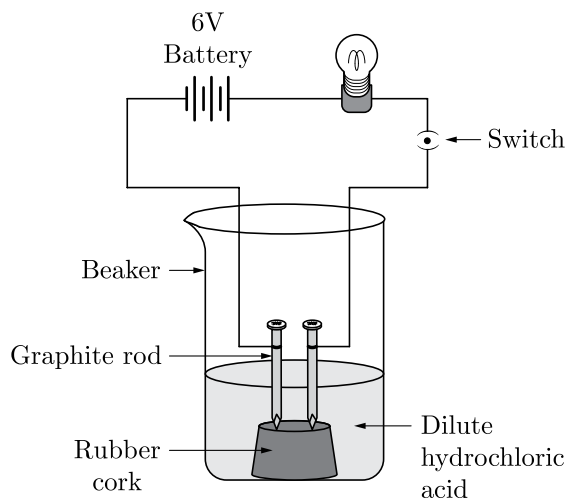
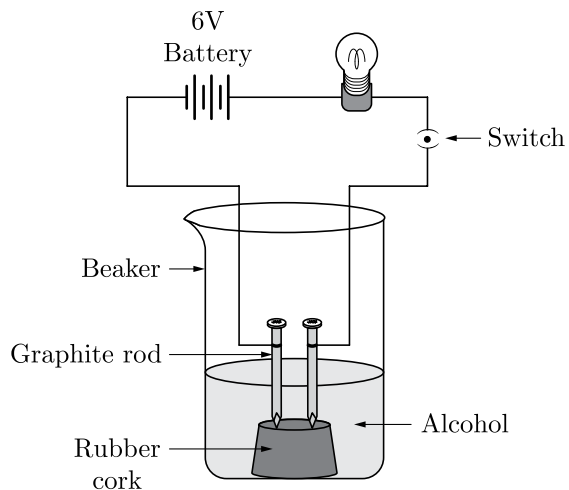

- (i) State your observation in terms of glowing of bulb when the switch is on.
- (ii) Justify your observations by giving reason in each case.
- (iii) Mention the change noticed with appropriate reason if the content of beaker B is replaced by sodium hydroxide solution.

Continue on next page.....

Click the Following Button to See the Free MS/Solutions

SOLUTIONS

31. Consider the following diagram :

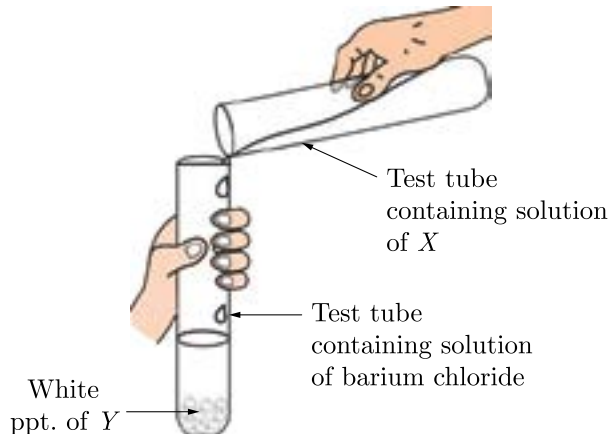

- (i) Identify 'X' and 'Y'.
 - (ii) What type of reaction is it?
 - (iii) Write a balanced chemical equation.
 - (iv) Explain why is it also called a double displacement reaction?
32. What are magnetic field lines? Justify the following statements:
- (i) Two magnetic field lines never intersect each other.
 - (ii) Magnetic field lines are closed curves.
- or**
- (i) What is the function of earth wire in electrical instruments?
 - (ii) Explain what is short circuiting of an electric supply?
 - (iii) What is the usual current rating of the fuse wire in the line to feed:
 - (a) lights and fans?
 - (b) appliances of 2 kW or more power?
33. What is a food chain? Why is the flow of energy in an ecosystem unidirectional? Explain briefly.

SECTION-D

Question no. 34 to 36 are Long answer questions.

34. (i) Name the mode of reproduction of the following organisms and state the important feature of each mode:
- (a) Planaria
 - (b) Hydra
 - (c) Rhizopus
- (ii) We can develop new plants from the leaves of Bryophyllum. Comment.
- (iii) List two advantages of vegetative propagation over other modes of reproduction.
- or**
- (i) "Use of a condom is beneficial for both the sexes involved in a sexual act." Justify this statement giving two reasons.
 - (ii) How do oral contraceptives help in avoiding pregnancies?
 - (ii) What is sex selective abortion? How does it affect a healthy society? (State any one consequence.)

Click the Following Button to See the Free MS/Solutions

SOLUTIONS

35. In our daily life, we use two types of electric current whose current-time graphs are given below:

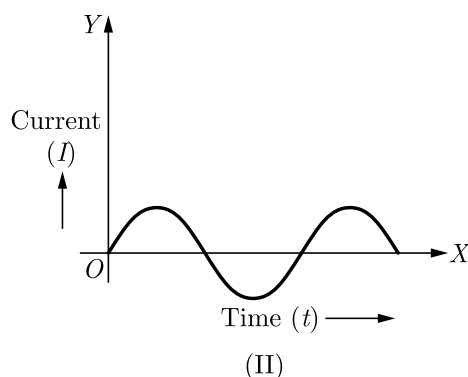
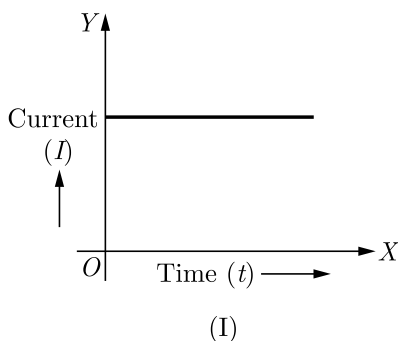

- (i) Identify the types of current in each case.
 - (ii) Identify any one source of each type of current.
 - (iii) What is frequency of current used in domestic supply in India?
 - (iv) On the basis of graphs, write difference between the two currents.
 - (v) Out of two, which one is used in transmitting electric power over Long distance and why?
36. (i) Carry out following conversions:
- (a) Ethanol to ethene
 - (b) Ethanol to Ethanoic acid
- (ii) Differentiate between addition reaction and substitution reaction. Give one example of each.

or

What are esters? How are esters prepared? Write the chemical equation for the reaction involved. What happens when an ester reacts with sodium hydroxide? Write the chemical equation for the reaction and also state the name and use of this reaction.

SECTION-E

Question no. 37 to 39 are case-based/data-based questions with 2 to 3 short sub-parts. Internal choice is provided in one of these sub-parts.

37. Refractive index refers to the measure of the bending of a ray of light when it passes from one medium to another medium. It can also be defined as the ratio of the velocity of a Light ray in vacuum or air to the velocity of Light in the medium. It has no unit.
- (i) The refractive index of diamond is 2.42. What is the meaning of this statement?

Continue on next page.....

Click the Following Button to See the Free MS/Solutions

SOLUTIONS

- (ii) The diagram below represents the path of a light ray from three different media A, B and C.

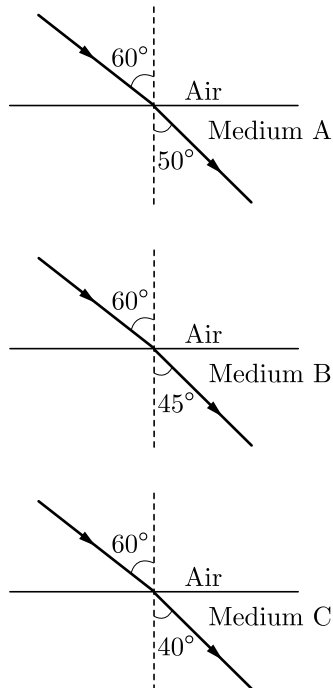

In which of the following media is the speed of light maximum?

- (iii) Refractive index of diamond with respect to glass is 1.6. If the absolute refractive index of glass is 1.5, then what is the absolute refractive index of diamond?
- or**
- (iv) Refractive index of turpentine oil, kerosene and alcohol are 1.47, 1.44 and 1.36 respectively. On the basis of this information, complete the following ray diagram to show path of ray of light through each medium.

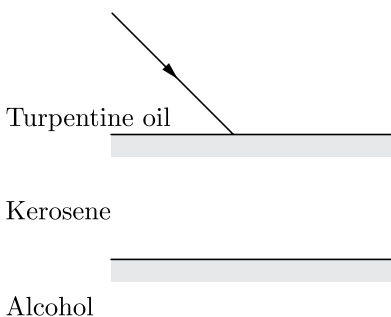

38. Sahil performed an experiment to study the inheritance pattern of genes. He crossed tall pea plants (T T) with short pea plants (tt) and obtained all tall plants in F_1 generation.
- What will be set of genes present in the F_1 generation?
 - Given reason why only tall plants are observed in F_1 progeny.
 - When F_1 plants were self-pollinated, a total of 800 plants were produced. How many of these would be tall, medium height or short plant? Give the genotype of F_2 generation.
- or**
- (iv) When F_1 plants were cross-pollinated with plants having tt genes, a total of 800 plants were produced. How many of these would be tall, medium height or short plants? Give the genotype of F_2 generation.

Click the Following Button to See the Free MS/Solutions

SOLUTIONS

39. A student took the samples of four metals A, B, C and D and added following solution one by one. The results obtained have been tabulated as follows:

Metal	Iron (II) sulphate	Copper (II) sulphate	Zinc sulphate	Silver nitrate
A	No reaction	Displacement	—	—
B	Displacement	—	No reaction	—
C	No reaction	No reaction	No reaction	Displacement
D	No reaction	No reaction	No reaction	No reaction

- (i) Which is the least reactive and most reactive metal? Give reasons.
 (ii) What would be observed, if 'B' is added to a solution of copper (II) sulphate and why? Also, arrange the metals A, B, C and D in order of increasing reactivity.

or

- (iii) In which test tube will the reaction take place? Write your observations for both the test tubes.

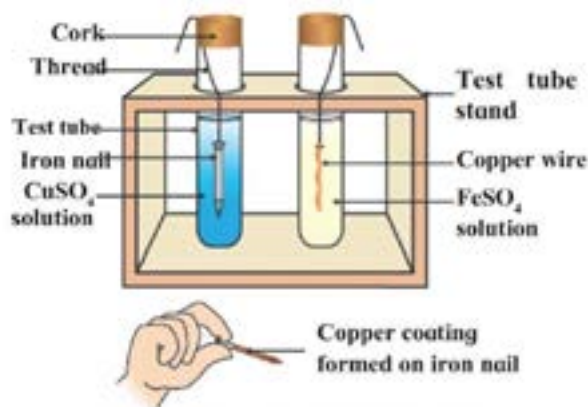

DOWNLOAD INDIA'S BEST STUDY MOBILE APP

- 30 Sample Paper with Solutions
- Chapterwise Question Bank of All Subject
- Previous 15 Years Solved Papers
- NCERT Solutions
- Case Study Questions with full Solutions
- **Word File of Material for Teachers**

Search by **NODIA** on Play Store to Download App

Add 89056 29969 in Your Class Whatsapp Group to Get Link

□□□□□□

Click the Following Button to See the Free MS/Solutions

SOLUTIONS

Sample Paper 17

Class X 2023-24

Science (086)

Time: 3 Hours

Max. Marks: 80

General Instructions:

1. This question paper consists of 39 questions in 5 sections.
 2. All questions are compulsory. However, an internal choice is provided in some questions. A student is expected to attempt only one of these questions.
 3. Section A consists of 20 Objective Type questions carrying 1 mark each.
 4. Section B consists of 6 Very Short questions carrying 02 marks each. Answers to these questions should be in the range of 30 to 50 words.
 5. Section C consists of 7 Short Answer type questions carrying 03 marks each. Answers to these questions should be in the range of 50 to 80 words.
 6. Section D consists of 3 Long Answer type questions carrying 05 marks each. Answer to these questions should be in the range of 80 to 120 words.
 7. Section E consists of 3 source-based/case-based units of assessment of 04 marks each with sub-parts.
-

SECTION-A

Select and write one most appropriate option out of the four options given for each of the questions 1 – 20.

1. The image shows a surgical method in females to prevent pregnancy.

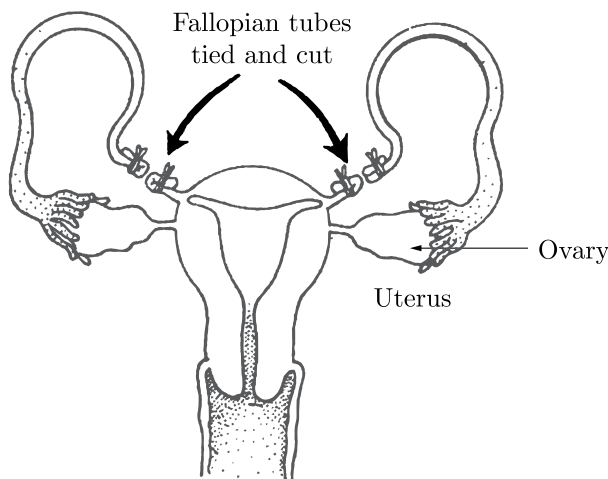

Which event will be likely prevented from this method?

- (a) Production of eggs
- (b) Maturation of eggs
- (c) Entry of sperm into the uterus
- (d) Entry of eggs into the uterus

Continue on next page.....

Click the Following Button to See the Free MS/Solutions

SOLUTIONS

2. The maximum resistance which can be made using four resistors each of resistance $(1/2) \Omega$ is:
 (a) 1Ω (b) 2Ω
 (c) 8Ω (d) 2.5Ω
3. The figure given below represents a single nephron from a mammalian kidney. Identify the labelled parts by selecting the most appropriate option.

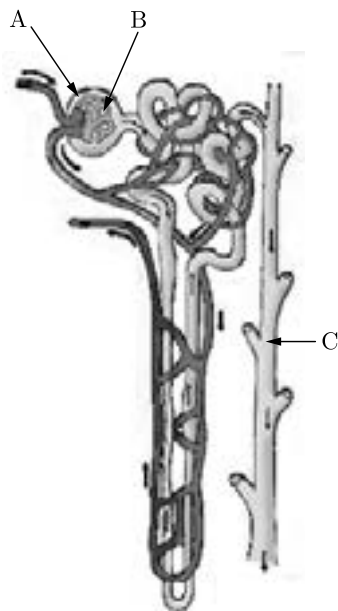

	A	B	C
(a)	Renal artery	Collecting duct	Bowman's capsule
(b)	Glomerulus	Bowman's capsule	Collecting duct
(c)	Bowman's capsule	Glomerulus	Collecting duct
(d)	Collecting duct	Glomerulus	Bowman's capsule

4. The diagram shows the human gut. Which numbered structures secrete digestive enzymes?

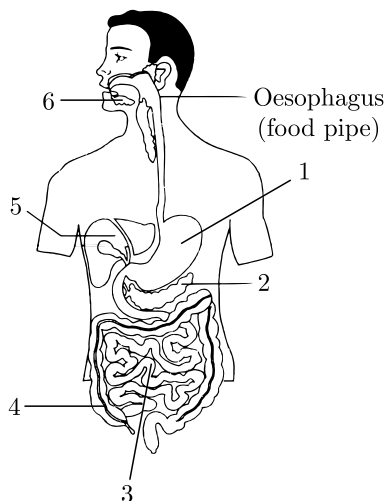

Continue on next page.....

Click the Following Button to See the Free MS/Solutions

SOLUTIONS

9. The image shows the magnetic field lines around a straight current carrying conductor.

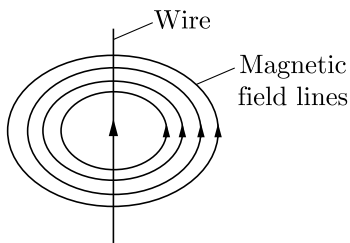

If the direction of the current in the straight wire is changed, what change in the magnetic field line will be observed?

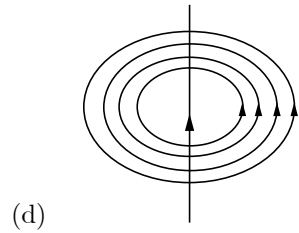
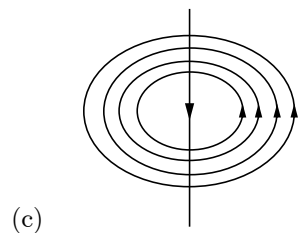
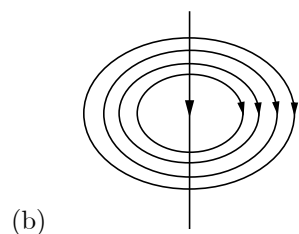
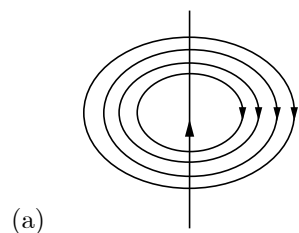

10. Magnetism at the centre of a bar magnet is zero. Since it can be explained by that the magnetic field lines are originated from pole and do not at centre. Match the terms of Column (I) with those of Column (II).

	Column(I)		Column(II)
(A)	Olfactory receptors	(i)	Tongue
(B)	Thermoreceptors (temperature receptors)	(ii)	Eye
(C)	Gustatoreceptors	(iii)	Nose
(D)	Photoreceptors	(iv)	Skin

Continue on next page.....

Click the Following Button to See the Free MS/Solutions

SOLUTIONS

- (a) (A)-(iii), (B)-(iv), (C)-(i), (D)-(ii)
 (b) (A)-(ii), (B)-(i), (C)-(iv), (D)-(iii)
 (c) (A)-(ii), (B)-(iv), (C)-(i), (D)-(iii)
 (d) (A)-(iii), (B)-(ii), (C)-(iv), (D)-(i)

11. Iron nail dipped in copper sulphate solution for about half an hour

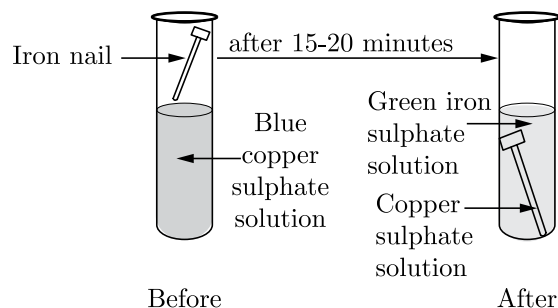

Which of the following is the correct observation of the reaction shown in the above set up?

- (a) Blue colour of copper sulphate solution is obtained
 (b) Copper displaces iron
 (c) Reaction is exothermic
 (d) No reaction takes place
12. If a round, green seeded pea plant (RRyy) is crossed with wrinkled, yellow seeded pea plant (rrYY), the seeds produced in F_1 generation are:
- (a) wrinkled and yellow
 (b) wrinkled and green
 (c) round and yellow
 (d) round and green
13. Four metals P , Q , R and S are tested with water, steam and dilute hydrochloric acid. The table given below shows the results of the experiment.

Metals	Reaction with water	Reaction with steam	Reaction with dil. HCl
P	×	✓	✓
Q	×	×	✓
R	✓	✓	✓
S	×	×	×

Between which two metals should hydrogen be placed in the series?

- (a) P and R
 (b) P and Q
 (c) R and S
 (d) Q and S

Continue on next page.....

Click the Following Button to See the Free MS/Solutions

SOLUTIONS

14. Select the incorrect option.

	Indicator	Colour in acidic medium	Colour in Basic medium
A.	Litmus (purple)	Red	Blue
B.	Flower of hydrangea plant (Blue)	Blue	Pink
C.	Red cabbage juice (Purple)	Red or Pink	Green
D.	Turmeric Juice (Yellow)	Colourless	Yellow

- (a) A
- (b) B
- (c) C
- (d) D

15. In one of the industrial processes used for manufacture of sodium hydroxide, a gas X is formed as by-product. The gas reacts with lime water to give a compound Y which is used as a bleaching agent in chemical industry. The compound X and Y could be:

- (a) CO_2 and CaOCl_2 respectively
- (b) H_2 and NaHCO_3 respectively
- (c) Cl_2 and NaHCO_3 respectively
- (d) Cl_2 and CaOCl_2 respectively

16. The figure given below represents the experiment carried out between conc. sulphuric acid and sodium chloride, which react with each other to form HCl gas.

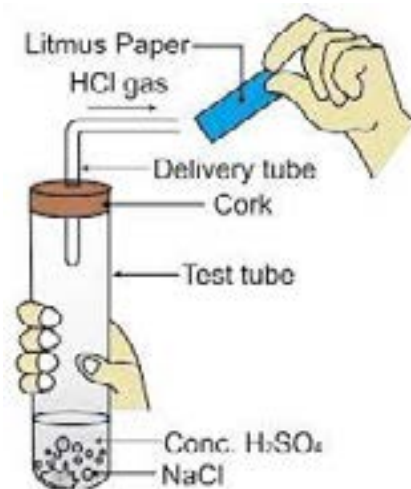

Blue litmus paper is brought near the mouth of the Delivery tube to check the presence of HCl acid but no change is observed in the colour of litmus paper because:

- (a) The litmus paper used is moist.
- (b) The litmus paper used is dry.
- (c) The litmus paper is kept very close to the mouth of the delivery tube.
- (d) Blue litmus paper does not change its colour with an acid.

Click the Following Button to See the Free MS/Solutions

SOLUTIONS

Question no. 17 to 20 are Assertion-Reasoning based questions.

17. **Assertion (A):** Monohybrid cross deals with inheritance of one pair of contrasting characters.
Reason (R): Dihybrid cross deals with inheritance of two pairs of contrasting characters.
- Both Assertion (A) and Reason (R) are true but Reason (R) is not the correct explanation of Assertion (A).
 - Both Assertion (A) and Reason (R) are true and Reason (R) is the correct explanation of Assertion (A).
 - Assertion (A) is false but Reason (R) is true.
 - Assertion (A) is true but Reason (R) is false.
18. **Assertion (A):** A fuse in a circuit prevents damage to the appliances and the circuit due to overloading.
Reason (R): Overloading occurs when the live wire and the neutral wire come into direct contact.
- Both Assertion (A) and Reason (R) are true but Reason (R) is not the correct explanation of Assertion (A).
 - Both Assertion (A) and Reason (R) are true and Reason (R) is the correct explanation of Assertion (A).
 - Assertion (A) is false but Reason (R) is true.
 - Assertion (A) is true but Reason (R) is false.
19. **Assertion (A):** Leaves are the main site of photosynthesis.
Reason (R): Chloroplast are present in leaves.
- Both Assertion (A) and Reason (R) are true but Reason (R) is not the correct explanation of Assertion (A).
 - Both Assertion (A) and Reason (R) are true and Reason (R) is the correct explanation of Assertion (A).
 - Assertion (A) is false but Reason (R) is true.
 - Assertion (A) is true but Reason (R) is false.
20. **Assertion (A):** Following are the members of a homologous series:
 CH_3OH , $\text{CH}_3\text{CH}_2\text{OH}$, $\text{CH}_3\text{CH}_2\text{CH}_2\text{OH}$
Reason (R): A series of compounds with same functional group, but differing by $-\text{CH}_2-$ unit is called a homologous series.
- Both Assertion (A) and Reason (R) are true but Reason (R) is not the correct explanation of Assertion (A).
 - Both Assertion (A) and Reason (R) are true and Reason (R) is the correct explanation of Assertion (A).
 - Assertion (A) is false but Reason (R) is true.
 - Assertion (A) is true but Reason (R) is false.

SECTION-B

Question no. 21 to 26 are very short answer questions.

21. Define the term power of accommodation. Write the modification in the curvature of the eye lens which enables us to see the nearby objects clearly?
- or
- A glass prism is able to produce a spectrum when white Light passes through it but a rectangular block of same transparent glass does not produce any spectrum. Why?
22. Two green plants are kept separately in oxygen free containers, one in the dark and the other in continuous light. Which one will live longer? Give reasons.

Continue on next page.....

Click the Following Button to See the Free MS/Solutions

SOLUTIONS

23. What are the problems caused by the non-biodegradable wastes that we generate?
24. In the following figure showing a germinating gram seed, name the parts labelled as *A*, *B*, and *C*:

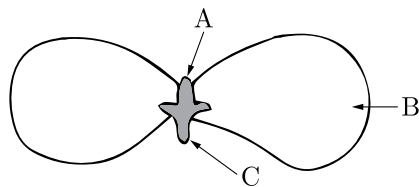

Why is part *B* considered to be important during germination?

25. Discuss the role of pH in:
- Digestive system, and
 - Causes of tooth decay.
- or**
- Give the constituents of baking powder.
 - Why does cake or bread swell on adding baking powder? Write chemical equation.
26. (i) Name one gustatory receptor and one olfactory receptor present in human beings.
 (ii) Write (a) and (b) in the given flow chart of neuron through which information travels as an electrical impulse.

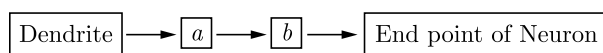

SECTION-C

Question no. 27 to 33 are short answer questions.

27. (i) We do not clean ponds or lakes, but an aquarium needs to be cleaned regularly. Why?
 (ii) Why is ozone layer getting depleted at the higher levels of the atmosphere? Mention one harmful effect caused by its depletion.
28. A student uses spectacles of focal length - 2.5 m.
- Name the defect of vision he is suffering from.
 - Which lens is used for the correction of this defect?
 - List two main causes of developing this defect.
 - Compute the power of this lens.
29. What is meant by solenoid? How does a current carrying solenoid behave? Give its main use.

or

Magnetic field lines are shown in the given diagram. A student makes a statement that the magnetic field at *A* is stronger than at *B*. Justify this statement. Also redraw the diagram and mark the direction of magnetic field lines.

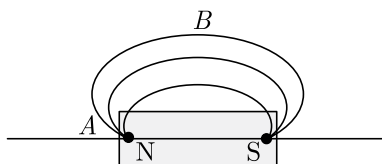

Click the Following Button to See the Free MS/Solutions

SOLUTIONS

30. Observe the given figure and answer the following questions:

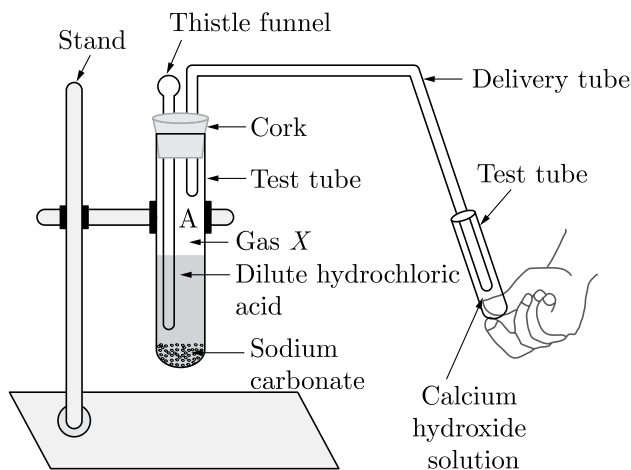

- (i) Which gas is evolved?
 - (ii) How will you test for the presence of gas evolved?
 - (iii) What will happen to the lime water?
 - (iv) What happens when the gas is passed for a longer time?
31. (i) Water has refractive index 1.33 and alcohol has refractive index 1.36. Which of the two mediums is optically denser? Give reason for your answer.
- (ii) Draw a ray diagram to show the path of a ray of light passing obliquely from water to alcohol.
- (iii) State the relationship between angle of incidence and angle of refraction in the above case.
32. State the functions of plant hormones. Name four different types of plant hormones.
- or**
- A squirrel is in a scary situation. Its body has to prepare for either fighting or running away. State the immediate changes that take place in its body so that the squirrel is able to either fight or run.
33. (i) Show diagrammatically the electrons between the atoms in the formation of MgO. Write symbols of cation and anion present in MgO.
- (ii) Name the solvent in which ionic compounds are generally soluble.
- (iii) Why are aqueous solution of ionic compounds able to conduct electricity?

SECTION-D

Question no. 34 to 36 are Long answer questions.

34. (i) "Blood circulation in fishes is different from the blood circulation in human beings." Justify the statement.
- (ii) Describe "blood circulation" in human beings.

or

Design an activity to show that chlorophyll is essential for photosynthesis.

Continue on next page.....

Click the Following Button to See the Free MS/Solutions

SOLUTIONS

35. (i) Deduce the expression for the equivalent resistance of the parallel combination of three resistors R_1 , R_2 and R_3 .
- (ii) Consider the following electric circuit.
- Which two resistors are connected in series?
 - Which two resistors are connected in parallel?
 - If every resistors of the circuit is of $2\ \Omega$, what current will flow in the circuit?.
36. (i) Dry pellets of a base X when kept in open absorbs moisture and turns sticky. The compound is also formed by chlor-alkali process. Write chemical name and formula of X . Describe chlor-alkali process with balanced chemical equation. Name the type of reaction that occurs when X is treated with dil. HCl . Write the chemical equation.
- (ii) While diluting an acid, why is it recommended that the acid should be added to water and not water to the acid?

or

Write the main difference between an acid and a base. With the help of suitable examples explain the term neutralisation and the formation of:

- acidic,
- basic and
- neutral salts.

SECTION-E

Question no. 37 to 39 are case-based/data-based questions with 2 to 3 short sub-parts. Internal choice is provided in one of these sub-parts.

37. Noor, a young student, was trying to demonstrate some properties of light in her science project work. She kept 'X' inside the box (as shown in the figure) and with the help of a laser pointer made light rays pass through the holes on one side of the box. She had a small butter-paper screen to see the spots of light being cast as they emerged.

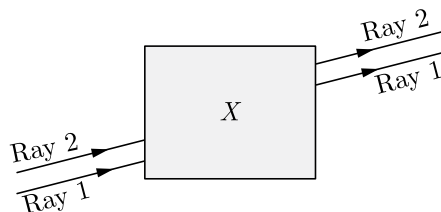

Continue on next page.....

- What could be the X that she placed inside the box to make the rays behave as shown?
 - A ray of light falls normally on a face of X . What are the values of angle of incidence and angle of refraction of this ray?
 - She measured the angles of incidence for both the rays on the left side of the box to be 48.6° . She knew the refractive index of the material X inside the box was 1.5. What will be the approximate value of angle of refraction? (Use the value $\sin 48.6 \approx 0.75$)
- or
- In an experiment with X , a student observed that a ray of light incident at an angle of 55° with the normal on one face of the X , after refraction strikes the opposite face of the X before emerging out into air making an angle of 40° with the normal. Draw a labelled diagram to show the path of this ray. What value would you assign to the angle of refraction and angle of emergence?

Click the Following Button to See the Free MS/Solutions

SOLUTIONS

38. The partially digested food coming from the stomach of a person enters a long and narrow organ *A* in his body. The organ *A* receives the secretions of two glands: liver and pancreas. Liver secretes a greenish-yellow liquid *B*. Pancreas secretes pancreatic juice which contains two digestive enzymes *C* and *D*. The intestinal juice completes the process of digestion of food. The inner wall of organ *A* has millions of tiny finger-like projections *E* which help in the rapid absorption of digested food into blood stream. The undigested part of food then passes into wider tube *F* which absorbs most of the water from undigested food. The last part of tube *F* called *G* stores this undigested food (or waste) for some time. The undigested food is then passed out through opening *H* as faeces in the process known as *I*.
- (i) Enlist the site of synthesis and storage of liquid *B*.
(ii) What are the digestive enzymes *C* and *D*?
(iii) Why is organ *A* in herbivores longer than in carnivores?
or
(iv) Name (a) tube *F* (b) part *G* (c) opening *H* and (d) process *I*.
39. An organic compound *A* of molecular formula C_2H_4 on reduction gives another compound *B* of molecular formula C_2H_6 . *B* on reaction with chlorine in the presence of sunlight gives *C* of molecular formula C_2H_5Cl .
- (i) Name the compounds *A* and *B*. Write the chemical equation for the conversion of *A* to *B*.
(ii) State the condition required for this reaction to take place.
or
(iii) Name the compound *C* and write the chemical equation for the conversion of *B* to *C*.

DOWNLOAD INDIA'S BEST STUDY MOBILE APP

- 30 Sample Paper with Solutions
- Chapterwise Question Bank of All Subject
- Previous 15 Years Solved Papers
- NCERT Solutions
- Case Study Questions with full Solutions
- **Word File of Material for Teachers**

Search by **NODIA** on Play Store to Download App

Add 89056 29969 in Your Class Whatsapp Group to Get Link

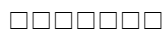

Click the Following Button to See the Free MS/Solutions

SOLUTIONS

Sample Paper 18

Class X 2023-24

Science (086)

Time: 3 Hours

Max. Marks: 80

General Instructions:

1. This question paper consists of 39 questions in 5 sections.
2. All questions are compulsory. However, an internal choice is provided in some questions. A student is expected to attempt only one of these questions.
3. Section A consists of 20 Objective Type questions carrying 1 mark each.
4. Section B consists of 6 Very Short questions carrying 02 marks each. Answers to these questions should be in the range of 30 to 50 words.
5. Section C consists of 7 Short Answer type questions carrying 03 marks each. Answers to these questions should be in the range of 50 to 80 words.
6. Section D consists of 3 Long Answer type questions carrying 05 marks each. Answer to these questions should be in the range of 80 to 120 words.
7. Section E consists of 3 source-based/case-based units of assessment of 04 marks each with sub-parts.

SECTION-A

Select and write one most appropriate option out of the four options given for each of the questions 1 – 20.

1. The given diagram is the structure of a/an-

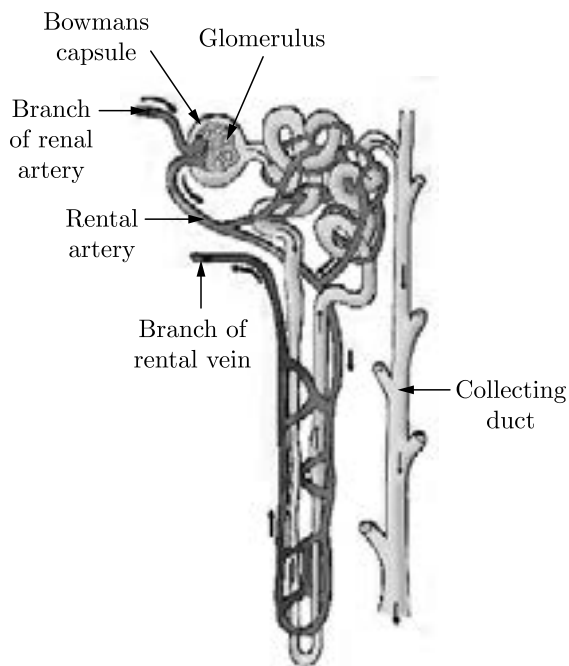

- (a) Alimentary canal
- (b) Respiratory tract
- (c) Nephron
- (d) Small intestine

Continue on next page.....

Click the Following Button to See the Free MS/Solutions

SOLUTIONS

2. The growth of tendril in pea plants is due to
- effect of light
 - effect of gravity
 - rapid cell divisions in tendrillar cells that are away from the support
 - rapid cell divisions in tendrillar cells in contact with the support
3. Which of the following is not a straight chain hydrocarbon ?
- $$\text{H}_3\text{C} - \text{CH}_2 - \text{CH}_2 - \text{CH}_2 - \text{CH}_2$$
 - $$\text{H}_3\text{C} - \text{CH}_2 - \text{CH}_2 - \text{CH}_2 - \text{CH}_2 - \text{CH}_3$$
 - $$\begin{array}{c} \text{CH}_3 \\ | \\ \text{H}_2\text{C} - \text{H}_2\text{C} - \text{H}_2\text{C} - \text{CH}_2 \\ | \\ \text{CH}_3 \end{array}$$
 - $$\begin{array}{c} \text{CH}_3 \\ \diagdown \\ \text{CH} - \text{CH}_2 - \text{CH}_2 - \text{CH}_3 \\ \diagup \\ \text{H}_3\text{C} \end{array}$$

4. Which of the following metal displace hydrogen from dilute acid?
- Zinc
 - Magnesium
 - Copper
 - Sodium

5.

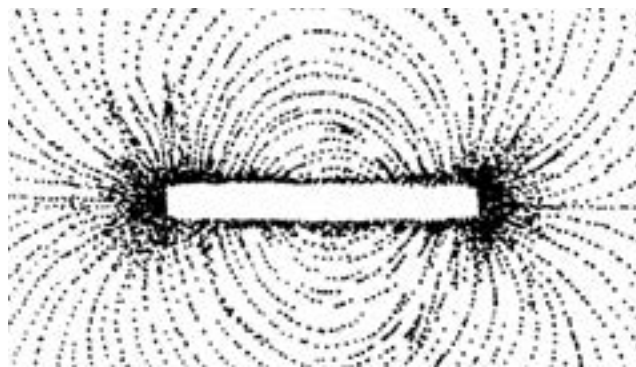

Choose the incorrect statement from the following regarding magnetic lines of field

- The direction of magnetic field at a point is taken to be the direction in which the north pole of a magnetic compass needle points.
- Magnetic field lines are closed curves.
- If magnetic field lines are parallel and equidistant, they represent zero field strength.
- Relative strength of magnetic field is shown by the degree of closeness of the field lines.

Continue on next page.....

Click the Following Button to See the Free MS/Solutions

SOLUTIONS

6. Which of the following statements is not correct?
- All metal carbonates react with acid to give a salt, water and carbon dioxide.
 - All metal oxides react with water to give salt and acid.
 - Some metals react with acids to give salt and hydrogen.
 - Some non-metal oxides react with water to form acid.

7. Which of the following pair is incorrect in the given table?

	Reaction	Reaction Name
(a)	$\text{CH}_4 + 2\text{O}_2 \rightarrow \text{CO}_2 + 2\text{H}_2\text{O}$	Combustion reaction and oxidation reaction
(b)	$\text{Pb}(\text{NO}_3)_2 + 2\text{KI} \rightarrow \text{PbI}_2 + 2\text{KNO}_3$	Double displacement and precipitation reaction
(c)	$\text{CaO} + \text{H}_2\text{O} \rightarrow \text{Ca}(\text{OH})_2$	Combination reaction
(d)	$\text{CuSO}_4 + \text{Zn} \rightarrow \text{ZnSO}_4 + \text{Cu}$	Combination reaction

8. Human males all the chromosomes are paired perfectly except one. This/these unpaired chromosomes is/are
- large chromosomes
 - small chromosomes
 - Y-chromosome
 - X-chromosome
- (i) and (ii)
 - (iii) only
 - (iii) and (iv)
 - (ii) and (iv)
9. In Spirogyra, asexual reproduction takes place by
- breaking up of filaments into smaller bits
 - division of a cell into two cells
 - division of a cell into many cells
 - formation of young cells from older cells
10. In the following circuits (Figure), heat produced in the resistor or combination of resistors connected to a 12 V battery will be

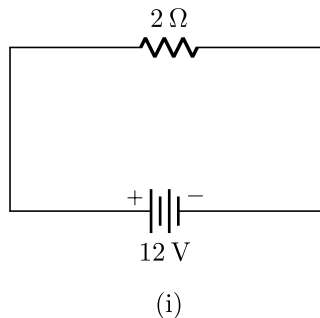

Continue on next page.....

Click the Following Button to See the Free MS/Solutions

SOLUTIONS

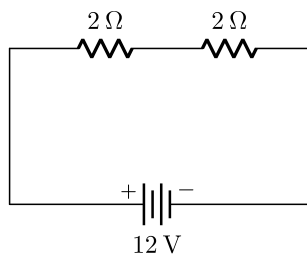

(ii)

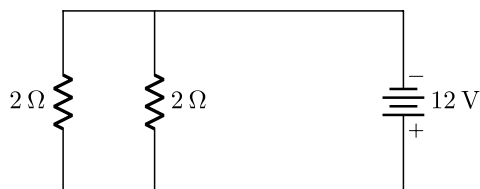

(iii)

- (a) same in all the cases
 (b) minimum in case (i)
 (c) maximum in case (ii)
 (d) maximum in case (iii)
11. A constant current flows in a horizontal wire in the plane of the paper from east to west as shown in Figure. The direction of magnetic field at a point will be North to South.

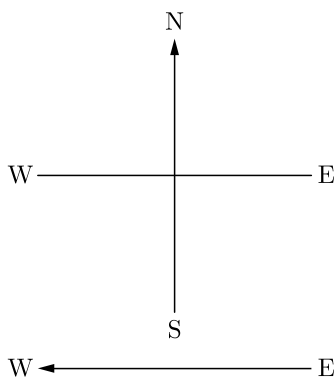

- (a) directly above the wire
 (b) directly below the wire
 (c) at a point located in the plane of the paper, on the north side of the wire
 (d) at a point located in the plane of the paper, on the south side of the wire.
12. For the start of respiration, a living cell requires?
- (a) Glucose
 (b) Glucose + O_2
 (c) O_2
 (d) Glucose + ATP

Click the Following Button to See the Free MS/Solutions

SOLUTIONS

13. When hydrogen sulphide gas is passed through a blue solution of copper sulphate, a black precipitate of copper sulphide is obtained and the sulphuric acid so formed remains in the solution. The reaction is an example of:
- combination reaction
 - displacement reaction
 - decomposition reaction
 - double displacement reaction
14. An electric kettle consumes 1 kW of electric power when operated at 220 V. A fuse wire of what rating must be used for it?
- 1 A
 - 2 A
 - 4 A
 - 5 A
15. The schematic diagram is given below :

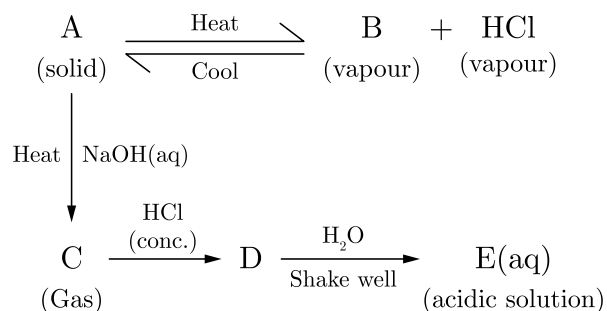

Which of the following is an incorrect statement?

- A and E are chemically same.
 - A and D are chemically same.
 - D and E are chemically same.
 - C and E are chemically same.
16. What happens when dilute hydrochloric acid is added to iron filings as shown in the figure?

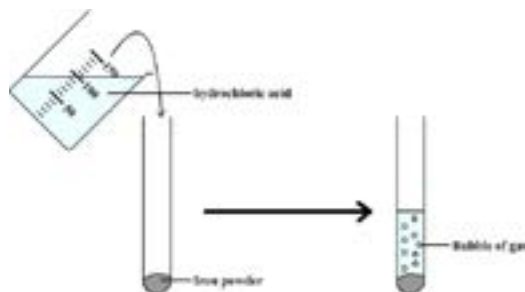

- Hydrogen gas and iron chloride are produced.
- Chlorine gas and iron hydroxide are produced.
- No reaction takes place.
- Iron salt and water are produced.

Click the Following Button to See the Free MS/Solutions

SOLUTIONS

Question no. 17 to 20 are Assertion - Reasoning based questions.

17. **Assertion :** Silver chloride turns grey in sunlight.
Reason : Silver is one of the least reactive metals.
- Both Assertion and Reason are True and Reason is the correct explanation of the Assertion.
 - Both Assertion and Reason are True but Reason is not the Correct explanation of the Assertion.
 - Assertion is True but the Reason is False.
 - Both Assertion and Reason are False.
18. **Assertion :** Mendel chose a number of varieties of garden pea as plant material for his experiments.
Reason : Garden pea has well defined characters and was bisexual.
- Both assertion (A) and reason (R) are true and reason (R) is the correct explanation of assertion (A).
 - Both assertion (A) and reason (R) are true but reason (R) is not the correct explanation of assertion (A).
 - Assertion (A) is true but reason (R) is false.
 - Assertion (A) is false but reason (R) is true.
19. **Assertion :** In plants, water is transported through phloem.
Reason : It is because sieve tubes are absent in phloem.
- Both Assertion and Reason are true and Reason is the correct explanation of Assertion.
 - Both Assertion and Reason are true but Reason is not the correct explanation of Assertion.
 - Assertion is true but Reason is false.
 - Both Assertion and Reason are false.
20. **Assertion :** In a conductor, free electrons keep on moving but no magnetic force acts on a conductor in a magnetic field.
Reason : Force on free electrons due to magnetic field always acts perpendicular to its direction of motion.
- Both assertion (A) and reason (R) are true and reason (R) is the correct explanation of assertion (A).
 - Both assertion (A) and reason (R) are true but reason (R) is not the correct explanation of assertion (A).
 - Assertion (A) is true but reason (R) is false.
 - Assertion (A) is false but reason (R) is true.

SECTION-B

Question no. 21 to 26 are very short answer questions.

21. Why are cooking vessels and water boilers generally made of copper and aluminium as shown in figure ?



or

Hydrogen is a non-metal, still it is given a place in the reactivity series. Why ?

Click the Following Button to See the Free MS/Solutions

SOLUTIONS

22. Explain the significance of peristaltic movement that occurs all along the gut during digestion.
23. How are the breathing movements controlled ?
24. Urine passed during summer is usually less in quantity and is some what thicker. Why is it so ?
25. Which component of white light deviates (i) the least and (ii) the most while passing through a glass prism? State the reason of this difference in deviation.

or

Name the part of eye where images formed in a normal human eye. State how the image position changes in myopia and hypermetropia.

26. Classify the following ecosystems into natural and artificial ecosystem :
Forest ecosystem, aquarium, Marine ecosystem and crop land ecosystem.

SECTION-C

Question no. 27 to 33 are short answer questions.

27. Identify the substances that are oxidised and that are reduced in the following reactions :
- (i) $\text{ZnO} + \text{C} \rightarrow \text{Zn} + \text{CO}$
- (ii) $\text{CuO} + \text{H}_2 \rightarrow \text{Cu} + \text{H}_2\text{O}$
- (iii) $\text{MnO}_2 + 4\text{HCl} \rightarrow \text{MnCl}_2 + 2\text{H}_2\text{O} + \text{Cl}_2$
28. State which of the following reaction will take place or not and why ?
- (i) $\text{Zn}(\text{s}) + \text{CuSO}_4(\text{aq}) \rightarrow \text{ZnSO}_4(\text{aq}) + \text{Cu}(\text{s})$
- (ii) $\text{Fe}(\text{s}) + \text{ZnSO}_4(\text{aq}) \rightarrow \text{FeSO}_4(\text{aq}) + \text{Zn}(\text{s})$
- (iii) $\text{Zn}(\text{s}) + \text{FeSO}_4(\text{aq}) \rightarrow \text{ZnSO}_4(\text{aq}) + \text{Fe}(\text{s})$
29. (i) What is the role of mutes in stomach ?
(ii) How exit of food from the stomach is regulated ?
(iii) Where does food enter from stomach ?

or

Write one function of each of the following components of the transport system in human beings

- (a) Blood vessels
(b) Lymph
(c) Heart
30. (a) Which mirror do we use as a rear-view mirror in vehicles ?
(b) Draw a ray diagram to illustrate the formation of an image when an object is placed anywhere in front of the mirror on its principal axis. State the nature and position of the image formed.
31. (a) Explain in brief, convex lens is converging in nature.
(b) A convex lens forms a real and inverted image of a needle at a distance of 50 cm from it. Where is the needle placed in front of convex lens if the image is equal to the size of the object ? Also find the power of the lens.

Click the Following Button to See the Free MS/Solutions

SOLUTIONS

32. Answer the following questions :

- (i) What is the direction of magnetic field lines outside a bar-magnet ?
- (ii) The magnetic field lines in a given region are getting crowded. What does it indicate ?
- (iii) State one advantage of AC over DC.

or

- (a) Give the significance of the following in a domestic circuit:
 - (i) electric meter,
 - (ii) earthing.
- (b) List two precautions that should be taken to avoid overloading.

33. Explain some harmful effects of agricultural practices on the environment.

SECTION-D

Question no. 34 to 36 are Long answer questions.

34. Write chemical equations to represent what happens when :

- (a) Ethanol burns in air.
- (b) Ethanol reacts with sodium metal.
- (c) Ethanol is heated with alkaline KMnO_4 .
- (d) Ethanol is heated with ethanoic acid in presence of few drops of concentrated sulphuric acid.
- (e) Ethanol is heated at 443 K with excess concentrated H_2SO_4 .

or

- (a) Give a chemical test to distinguish between saturated and unsaturated hydrocarbons.
- (b) Name the products formed when ethane burns in air. Write the balanced chemical equation for the reaction showing the types of energies liberated.
- (c) Why is reaction between methane and chlorine in the presence of sunlight considered a substitution reaction.

35. (a) "Use of a condom is beneficial for both the sexes involved in a sexual act." Justify this statement giving two reasons.

(b) How do oral contraceptive help in avoiding pregnancies ?

(c) What is sex selective abortion? How does it affect a healthy society ? (State any one consequence)

or

- (i) Describe the various steps involved in the process of binary fission with the help of a diagram.
- (ii) Why do multicellular organisms use complex way of reproduction ?

36. When a current is passed through the circular loop of wire, a magnetic field lines near the coil are nearly circular and concentric. At the centre of the circular loop, the magnetic field lines are straight.

The strength of the magnetic field produced by a current-carrying circular coil (or circular wire) depends on :

- (i) current flowing through the coil.
- (ii) radius of the circular coil.
- (iii) number of turns of wire in the circular coil.

The direction of the field lines can be found by applying Right-Hand Thumb Rule.

Continue on next page.....

Click the Following Button to See the Free MS/Solutions

SOLUTIONS

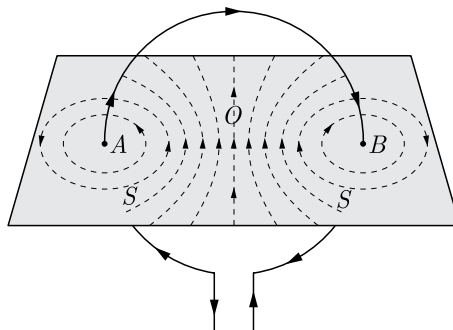

- (i) State Right-hand Thumb rule.
- (ii) A long horizontal power line is carrying a current of 100 A in the east-west direction. What is the direction of magnetic field at a point 1.0 m below it ?
- (iii) What type of curve we get, between magnetic field and distance along the axis of a current carrying circular coil ?
- (iv) If a current carrying straight conductor is placed in east-west direction, then find the direction of the force experienced by the conductor due to earth's magnetic field.

SECTION-E

Question no. 37 to 39 are case-based/data -based questions with 2 to 3 short sub-parts. Internal choice is provided in one of these sub-parts.

- 37.** Refining is the process of purification of metals. One of the important method of refining is electrolysis. In electrolysis, electrical energy is used to bring about a non-spontaneous redox reaction. This is done by passing an electric current through a liquid containing ions, known as an electrolyte. In contrast to metals, the current in electrolytes is carried by the movement of ions rather than the movement of electrons. The solid conductors inserted into the liquid are called electrodes, the one with a positive charge is called the anode (because it attracts anions) and the one with the negative charge is called the cathode.

A diagrammatic representation of electrolysis of copper is shown below :

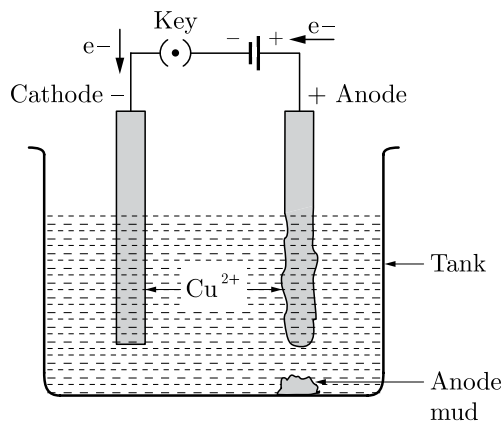

- (i) Name the electrolyte used in refining of copper.
 - a. $\text{Cu} \longrightarrow \text{Cu}^{2+} + 2\text{e}^-$
 - b. $\text{Cu}^{2+} + 2\text{e}^- \longrightarrow \text{Cu}$
 Which of these two reactions occur at cathode and anode?
- or**
- (iii) What is anode mud ? Name two metals which can be refined by electrolytic method.

Click the Following Button to See the Free MS/Solutions

SOLUTIONS

38. The growing size of the human population is a cause of concern for all people. The rate of birth and death in a given population will determine its size. Reproduction is the process by which organisms increase their population. The process of sexual maturation for reproduction is gradual and takes place while general body growth is still going on. Some degree of sexual maturation does not necessarily mean that the mind or body is ready for sexual acts or for having and bringing up children. Various contraceptive devices are being used by human beings to control the size of population.

- (i) List two common signs of sexual maturation in boys and girls.
- (ii) What is the result of reckless female foeticide ?
- (iii) Which contraceptive method changes the hormonal balance of the body ?

or

- (iv) Write two factors that determine the size of a population.

39. When light ray goes from one transparent medium to another transparent medium, it suffers a change in direction, into second medium. The extent of the change in direction suffered by the phenomenon of change in the path of light rays when going from one medium to another medium is known as refraction. Ray is a given pair of media can be expressed in terms of refractive index. The refractive index is related to an important physical quantity in the relative speed of light in different media.

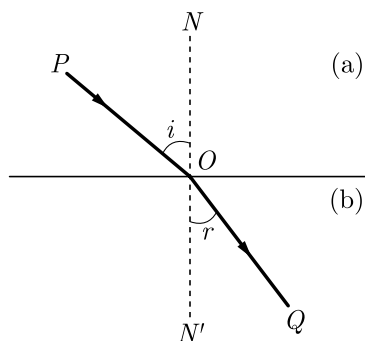

- (i) A ray of light enters into the glass from air. Does it bend towards normal ?
- (ii) What is the unit of refractive index ?
- (iii) Light enters from air to glass having refractive index 1.50. What is the speed of light in the glass? The speed of light in vacuum is $3 \times 10^8 \text{ ms}^{-1}$.

or

- (iii) When light goes from one medium to another, which of the three parameters, frequency, wavelength, velocity change ?

□□□□□□

DOWNLOAD INDIA'S BEST STUDY MOBILE APP

- 30 Sample Paper with Solutions
- Chapterwise Question Bank of All Subject
- Previous 15 Years Solved Papers
- NCERT Solutions
- Case Study Questions with full Solutions
- **Word File of Material for Teachers**

Search by **NODIA** on Play Store to Download App

Add 89056 29969 in Your Class Whatsapp Group to Get Link

Click the Following Button to See the Free MS/Solutions

SOLUTIONS

Sample Paper 19

Class X 2023-24

Science (086)

Time: 3 Hours

Max. Marks: 80

General Instructions:

1. This question paper consists of 39 questions in 5 sections.
 2. All questions are compulsory. However, an internal choice is provided in some questions. A student is expected to attempt only one of these questions.
 3. Section A consists of 20 Objective Type questions carrying 1 mark each.
 4. Section B consists of 6 Very Short questions carrying 02 marks each. Answers to these questions should be in the range of 30 to 50 words.
 5. Section C consists of 7 Short Answer type questions carrying 03 marks each. Answers to these questions should be in the range of 50 to 80 words.
 6. Section D consists of 3 Long Answer type questions carrying 05 marks each. Answer to these questions should be in the range of 80 to 120 words.
 7. Section E consists of 3 source-based/case-based units of assessment of 04 marks each with sub-parts.
-

SECTION-A

Select and write one most appropriate option out of the four options given for each of the questions 1 – 20.

1. Sodium kept immersed in kerosene oil because-
 - (a) Sodium is most reactive metal.
 - (b) Sodium is less reactive metal.
 - (c) Sodium is not a reactive metal.
 - (d) None of these.

2. A sample of soil is mixed with water and allowed to settle. The clear supernatant solution turns the pH paper yellowish-orange. Which of the following would change the colour of this pH paper to greenish-blue?
 - (a) Lemon Juice
 - (b) Vinegar
 - (c) Common salt
 - (d) An antacid

3. Identify the unsaturated compounds from the following :
 - (i) Propane
 - (ii) Propene
 - (iii) Propyne
 - (iv) Chloropropane
 - (a) (i) and (ii)
 - (b) (ii) and (iv)
 - (c) (iii) and (iv)
 - (d) (ii) and (iii)

Continue on next page.....

Click the Following Button to See the Free MS/Solutions

SOLUTIONS

4. In the given figure the various trophic levels are shown in a pyramid. At which trophic level is maximum energy available ?

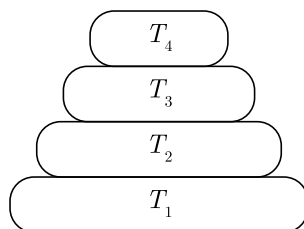

- (a) T_4 (b) T_2
 (c) T_1 (d) T_3
5. Which of the following is an example of displacement reaction?
- (a) $\text{NaOH} + \text{HNO}_3 \rightarrow \text{NaNO}_3 + \text{H}_2\text{O}$
 (b) $\text{Cu} + 2\text{AgNO}_3 \rightarrow \text{Cu}(\text{NO}_3)_2 + 2\text{Ag}$
 (c) $2\text{Hg} + \text{O}_2 \rightarrow 2\text{HgO}$
 (d) $\text{FeCl}_3 + 2\text{NaOH} \rightarrow 3\text{NaCl} + \text{Fe}(\text{OH})_3$
6. Process of conversion of light energy to chemical energy and splitting of water molecules into hydrogen and oxygen in plants is known as
- (a) Photosynthesis
 (b) Photoperiodism
 (c) Plant nutrition
 (d) Plant hormone functions
7. A prism ABC (with BC as base) is placed in different orientations. A narrow beam of white light is incident on the prism as shown in figure. In which of the following cases, after dispersion, the third colour from the top corresponds to the colour of the sky?

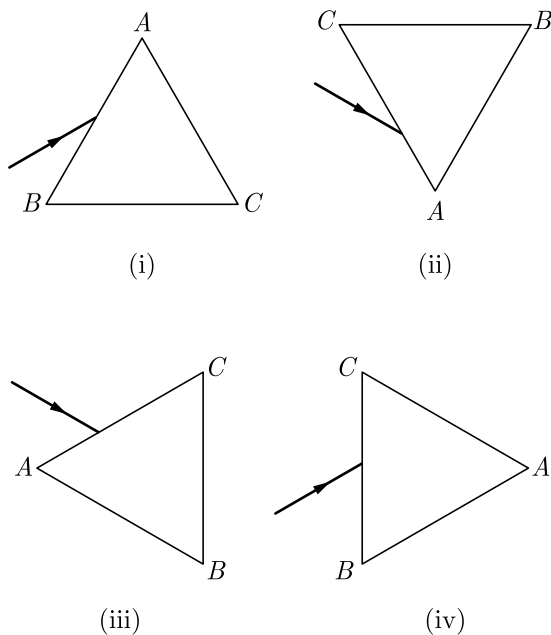

- (a) (i) (b) (ii)
 (c) (iii) (d) (iv)

Click the Following Button to See the Free MS/Solutions

SOLUTIONS

8. A round, green seeded pea plant (RR yy) is crossed with wrinkled, yellow seeded pea plant, (rr YY) the seeds produced in F₁ generation are
- round and yellow
 - round and green
 - wrinkled and green
 - wrinkled and yellow
9. Rusting of iron can be prevented by:



- Painting
 - Galvanisation
 - Electrolytic refining
 - Alloying
- Which of the above are correct?
- 1, 2 and 3
 - 1, 2 and 4
 - 2, 3 and 4
 - 1, 2, 3 and 4
10. Which of the following is a feasible reaction?
- $\text{Ba (s)} + \text{K}_2\text{SO}_4\text{(aq)} \longrightarrow \text{BaSO}_4\text{(aq)} + 2\text{K (s)}$
 - $\text{Zn (s)} + 2\text{AgNO}_3\text{(aq)} \longrightarrow \text{Zn(NO}_3)_2\text{(aq)} + 2\text{Ag (s)}$
 - $\text{Mg (s)} + \text{Na}_2\text{SO}_4\text{(aq)} \longrightarrow \text{MgSO}_4\text{(aq)} + 2\text{Na (s)}$
 - $\text{Cu (s)} + \text{MgSO}_4\text{(aq)} \longrightarrow \text{CuSO}_4\text{(aq)} + \text{Mg (s)}$
11. Electrical impulse travels in a neuron from
- Dendrite → axon → axonal end → cell body
 - Cell body → dendrite → axon → axonal end
 - Dendrite → cell body → axon → axonal end
 - Axonal end → axon → cell body → dendrite

Continue on next page.....

Click the Following Button to See the Free MS/Solutions

SOLUTIONS

12. Some of the substances used in making of a modern safety match box are listed below :



1. Antimony trisulfide
2. Glass powder
3. Potassium chlorate
4. Red phosphorus

The head of modern safety match stick contains :

- (a) 1 and 4
 - (b) 2 and 3
 - (c) 3 and 4
 - (d) 3 and 1
13. Which among the following is not the function of testes at puberty?
- (a) formation of germ cells
 - (b) secretion of testosterone
 - (c) development of placenta
 - (d) secretion of estrogen
- (a) (i) and (ii)
 - (b) (ii) and (iii)
 - (c) (iii) and (iv)
 - (d) (i) and (iv)

14.

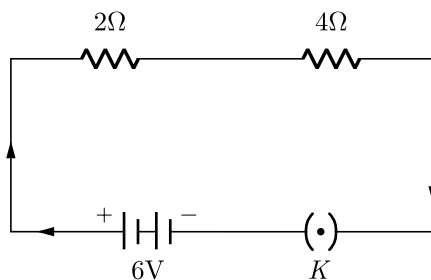

In an electrical circuit two resistors of 2Ω and 4Ω respectively are connected in series to a 6 V battery as shown in the figure. The heat dissipated by the 4Ω resistor in 5 s will be

- (a) 5 J
- (b) 10 J
- (c) 20 J
- (d) 30 J

Continue on next page.....

Click the Following Button to See the Free MS/Solutions

SOLUTIONS

15. When a 4 V battery is connected across an unknown resistor, there is a current of 100 mA in the circuit. The value of the resistance of the resistor is

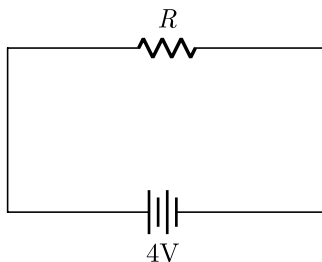

- (a) 4Ω
(b) 40Ω
(c) 400Ω
(d) 0.4Ω
16. Which one of the following statements is correct?
(a) The rainbow is produced by the reflection of white sun light by water drops in the atmosphere.
(b) The blue colour of the sky is due to scattering of light.
(c) The stars appear higher in the sky than actually are, due to scattering of light.
(d) The planets twinkle at night due to atmospheric refraction of light.

Question no. 17 to 20 are Assertion-Reasoning based questions.

17. **Assertion :** Chemical equations can be made more informative.
Reason : We can write physical state of reactants and products, temperature and pressure, name of catalyst used etc.
(a) Both Assertion and Reason are True and Reason is the correct explanation of the Assertion.
(b) Both Assertion and Reason are True but Reason is not the Correct explanation of the Assertion.
(c) Assertion is True but the Reason is False.
(d) Both Assertion and Reason are False.
18. **Assertion :** Traits like eye colour or height are inherited traits.
Reason : Inherited traits are not transferred from parents to young ones.
(a) Both assertion (A) and reason (R) are true and reason (R) is the correct explanation of assertion (A).
(b) Both assertion (A) and reason (R) are true but reason (R) is not the correct explanation of assertion (A).
(c) Assertion (A) is true but reason (R) is false.
(d) Assertion (A) is false but reason (R) is true.
19. **Assertion :** Aerobic animals are not truly aerobic.
Reason : Anaerobically they produce lactic acid.
(a) Both Assertion and Reason are true and Reason is the correct explanation of Assertion.
(b) Both Assertion and Reason are true but Reason is not the correct explanation of Assertion.
(c) Assertion is true but Reason is false.
(d) Both Assertion and Reason are false.

Continue on next page.....

Click the Following Button to See the Free MS/Solutions

SOLUTIONS

20. **Assertion :** Electric appliances with metallic body have three connections, whereas an electric bulb has two pin connections.

Reason : Three pin connections reduce heating of connecting wires.

- (a) Both assertion (A) and reason (R) are true and reason (R) is the correct explanation of assertion (A).
 (b) Both assertion (A) and reason (R) are true but reason (R) is not the correct explanation of assertion (A).
 (c) Assertion (A) is true but reason (R) is false.
 (d) Assertion (A) is false but reason (R) is true.

SECTION-B

Question no. 21 to 26 are very short answer questions.

21. Name two metals that start floating after sometime when immersed in water and why ?

or

Explain how mercury is extracted from its sulphide ore (Cinnabar). Give equations of the reactions involved.

22. A certain tissue in a green plant somehow got blocked and the leaves wilted. What was the tissue that got blocked?

23. Write one function each of the salivary glands, liver and pancreas.

24. Why and how does water enter continuously into the root xylem ?

25. The current flowing through a resistor connected in a circuit and the potential difference developed across its ends are as shown in the diagram by milliammeter and voltmeter readings respectively :

- (a) What are the least counts of these meters?

- (b) What is the resistance of the resistor?

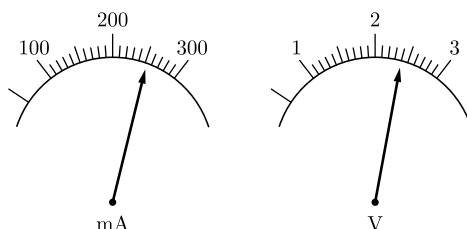

or

A $V-I$ graph for a nichrome wire is given below. What do you infer from this graph? Draw a labelled circuit diagram to obtain such a graph.

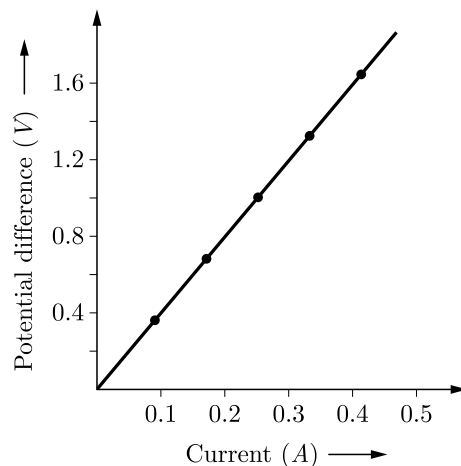

Click the Following Button to See the Free MS/Solutions

SOLUTIONS

26. Name the four types of teeth present in adult human and mention their main functions.

SECTION-C

Question no. 27 to 33 are short answer questions.

27. What does a balanced chemical equation convey ?
28. (a) An element X on reacting with oxygen forms an oxide X_2O . The oxide dissolves in water and turns blue litmus red. Predict the nature of the element whether metal or non-metal.
 (b) A solution of copper sulphate was kept in an iron pot. After few days, the pot developed some holes in it. How will you account for this ?
29. Define the two main methods of reproduction in living organisms.

or

List six specific characteristics of sexual reproduction.

30. Ram placed an object in front of a convex lens of focal length 15 cm. The image formed is three times the size of the object. Calculate the two possible distances of the object from the lens.
31. The image of a candle flame placed at a distance of 30 cm from a mirror is formed on a screen placed in front of the mirror at a distance of 60 cm from its pole. What is the nature of the mirror ? Find its focal length, if the height of the flame is 2.4 cm, find the height of its image. State whether the image formed is erect or inverted.
32. Diagram below shows a circuit containing a coil wound over a long and thin hollow cardboard tube. Copy the diagram.

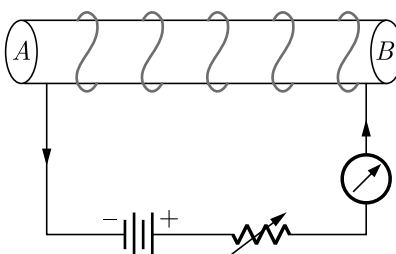

- (i) Show the polarity acquired by each face of the solenoid.
 (ii) Draw the magnetic field lines of force inside the coil and also show their direction.
 (iii) Mention two methods to increase the strength of the magnetic field inside the coil.

or

State the factors on which the resistance of a cylindrical conductor depends. How will resistance of a conductor change if it is stretched so that its length is doubled ?

33. (a) What is full form of (i) UNEP (ii) CFCs.
 (b) On what basis are organisms grouped as producers, consumers and decomposer ?
 (c) Write two problems that would arise if there were no decomposer in an ecosystem.

Click the Following Button to See the Free MS/Solutions

SOLUTIONS

SECTION-D

Question no. 34 to 36 are Long answer questions.

34. (a) Draw electron dot structure of methane molecule.
(b) Identify the functional groups present in the following compounds :
(i) C_2H_6O
(ii) C_2H_4O
(c) A mixture of oxygen and ethyne is burnt for welding. Why do you think a mixture of ethyne and air is not used for welding ?

or

- (a) Explain why carbon forms covalent bond? Give two reasons for carbon forming a large number of compounds.
(b) Explain the formation of ammonia molecule.
35. What is vegetative propagation? Briefly describe various methods of vegetative propagation.

or

- (a) Draw diagram of human alimentary canal and label the following :
(i) Part in which starch digestion starts.
(ii) Part in which bile is stored.
(iii) Part in which nutrients are absorbed.
(iv) Part in which water is absorbed.
(b) Mention the role of hydrochloric acid in the stomach.
(c) What function is served by the following :
(i) Gastric sphincter
(ii) Anal sphincter
36. (a) What is an electromagnet ? List any two uses.
(b) Draw a labelled diagram to show how an electromagnet is made.
(c) State the purpose of soft iron core used in making an electromagnet.
(d) List two ways of increasing the strength of an electromagnet if the material of the electromagnet is fixed.

SECTION-E

Question no. 37 to 39 are case-based/data -based questions with 2 to 3 short sub-parts. Internal choice is provided in one of these sub-parts.

37. When a metal is attacked by substances around it such as moisture, acids, etc., it is said to corrode, and this process is called corrosion. The black coating on silver, green coating on copper and reddish-brown powder on iron surface are some examples of corrosion.

Continue on next page.....

Click the Following Button to See the Free MS/Solutions

SOLUTIONS



- (i) What is the name given to the corrosion of iron?
- (ii) What is the formula of green colour coating on copper?
- (iii) Name two methods to prevent corrosion of iron.

or

- (iv) Is corrosion a redox reaction?

38. The human brain is the central organ of the human nervous system and with the spinal cord makes up the central nervous system. The brain consists of the cerebrum, the brain-stem and the cerebellum. It controls most of the activities of the body, processing, integrating and coordinating the information it receives from the sense organs and making decisions as to the instructions sent to the rest of the body. The brain is contained in and protected by, the skull bones of the head. The cerebrum is the largest part of the human brain. It is divided into two cerebral hemispheres. The cerebral cortex is an outer layer of grey matter, covering the core of white matter. The cortex is split into the neocortex and the much smaller allocortex. The neocortex is made up of six neuronal layers, while the allocortex has three or four. Each hemisphere is conventionally divided into four lobes – the frontal, temporal, parietal and occipital lobes. The frontal lobe is associated with executive functions including self-control, planning, reasoning and abstract thought, while the occipital lobe is dedicated to vision. The brain is protected by the skull, suspended in cerebrospinal fluid and isolated from the bloodstream by the blood brain barrier. However, the brain is still susceptible to damage, disease and infection. Damage can be caused by trauma, or a loss of blood supply known as a stroke. The brain is susceptible to degenerative disorders, such as Parkinson's disease, dementias including Alzheimer's disease and multiple sclerosis. Psychiatric condition, including schizophrenia and clinical depression, are thought to be associated with brain dysfunctions. The brain can also be the site of tumours, both benign and malignant; these mostly originate from other sites in the body. The study of the anatomy of the brain is neuroanatomy, while the study of its function is neuroscience.

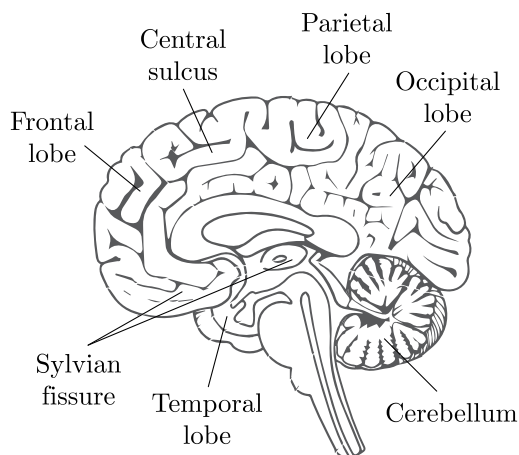

Continue on next page.....

Click the Following Button to See the Free MS/Solutions

SOLUTIONS

- (i) Which is the central part of the nervous system?
- (ii) What is the largest part of the human brain?
- (iii) What are the functions of the brain?

or

- (iv) What is the branch which studies the anatomy of brain?

- 39.** The human eye is like a camera. Its lens system forms an image on a light-sensitive screen called the retina. Light enters the eye through a thin membrane called the cornea. It forms the transparent bulge on the front surface of the eyeball as shown in the figure. The crystalline lens merely provides the finer adjustment of focal length required to focus objects at different distances on the retina. We find a structure called iris behind the cornea. Iris is a dark muscular diaphragm that controls the size of the pupil. The pupil regulates and controls the amount of light entering the eye.

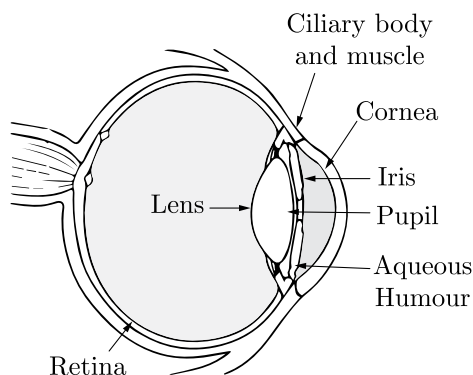

The Human Eye

There are mainly three common refractive defects of vision. These are (i) myopia or near-sightedness, (ii) hypermetropia or far-sightedness, and (iii) Presbyopia. These defects can be corrected by the use of suitable spherical lenses.

- (i) What is the function of pupil in the human eye ?
- (ii) What is the far point and near point of human eye with normal vision ?
- (iii) A student has difficulty reading the blackboard while sitting in the last row. What could be the defect the child is suffering from ?

or

- (iv) What is the function of iris in human eye ?

□□□□□□

DOWNLOAD INDIA'S BEST STUDY MOBILE APP

- 30 Sample Paper with Solutions
- Chapterwise Question Bank of All Subject
- Previous 15 Years Solved Papers
- NCERT Solutions
- Case Study Questions with full Solutions
- **Word File of Material for Teachers**

Search by **NODIA** on Play Store to Download App

Add 89056 29969 in Your Class Whatsapp Group to Get Link

Click the Following Button to See the Free MS/Solutions

SOLUTIONS

Sample Paper 20

Class X 2023-24

Science (086)

Time: 3 Hours

Max. Marks: 80

General Instructions:

1. This question paper consists of 39 questions in 5 sections.
2. All questions are compulsory. However, an internal choice is provided in some questions. A student is expected to attempt only one of these questions.
3. Section A consists of 20 Objective Type questions carrying 1 mark each.
4. Section B consists of 6 Very Short questions carrying 02 marks each. Answers to these questions should be in the range of 30 to 50 words.
5. Section C consists of 7 Short Answer type questions carrying 03 marks each. Answers to these questions should be in the range of 50 to 80 words.
6. Section D consists of 3 Long Answer type questions carrying 05 marks each. Answer to these questions should be in the range of 80 to 120 words.
7. Section E consists of 3 source-based/case-based units of assessment of 04 marks each with sub-parts.

SECTION-A

Select and write one most appropriate option out of the four options given for each of the questions 1 – 20.

1. An experiment is set up as shown. Flasks 1 and 2 contain lime water. Air is pumped through the flasks.

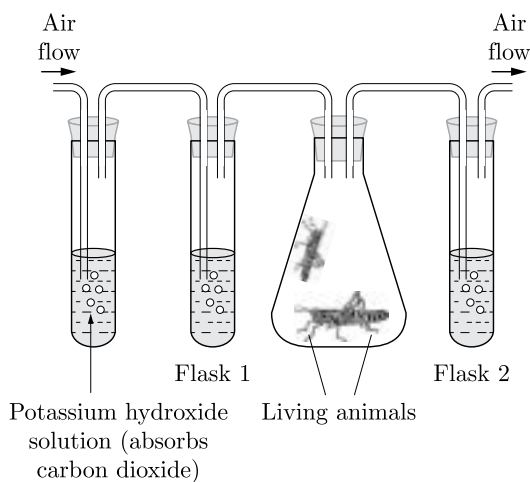

What is the appearance of lime water in flasks 1 and 2 after a period of ten minutes?

	Flask 1	Flask 2
(a)	Clear	Clear
(b)	Clear	White/Cloudy
(c)	White/Cloudy	Clear
(d)	White/Cloudy	White/Cloudy

Continue on next page.....

Click the Following Button to See the Free MS/Solutions

SOLUTIONS

2. Which of the following correctly describes the magnetic field near long straight wire ?
- the field consists of straight lines perpendicular to the wire.
 - the field consists of straight lines parallel to the wire.
 - the field consists of radial lines originating from the wire.
 - the field consists of concentric circles centered on the wire.
3. Identify the substances that is oxidized and the substances that is reduced in the following reactions:
- $$\text{CuO (s)} + \text{H}_2\text{(g)} \longrightarrow \text{Cu (s)} + \text{H}_2\text{O (l)}$$
- H_2 , CuO
 - H_2 , H_2O
 - H_2 , Cu
 - Cu , H_2
4. An element reacts with oxygen to give a compound with a high melting point. This compound is also soluble in water. The element is likely to be
- calcium
 - carbon
 - silicon
 - iron
- 5.

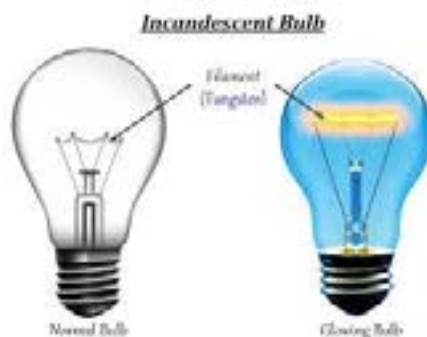

- A current of 1 A is drawn by a filament of an electric bulb shown in the figure. Number of electrons passing through a cross section of the filament in 16 seconds would be roughly
- 10^{20}
 - 10^{16}
 - 10^{18}
 - 10^{23}
6. Two pink coloured flowers on crossing resulted in 1 red, 2 pink and 1 white flower progeny. The nature of the cross will be
- double fertilisation
 - self pollination
 - cross fertilisation
 - no fertilisation

Continue on next page.....

Click the Following Button to See the Free MS/Solutions

SOLUTIONS

7. Which of the following is the structural formula of ethyne ?

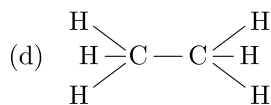
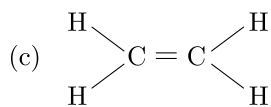
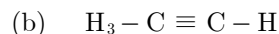
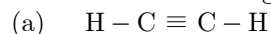

8. From the mouth the food is taken to the stomach through

(a) Bile duct

(b) Pancreas

(c) Diaphragm

(d) Oesophagus

9. A circular loop placed in a plane perpendicular to the plane of paper carries a current when the key is ON. The current as seen from points A and B (in the plane of paper and on the axis of the coil) is anti-clockwise and clockwise respectively. The magnetic field lines point from B to A . The N -pole of the resultant magnet is on the face close to

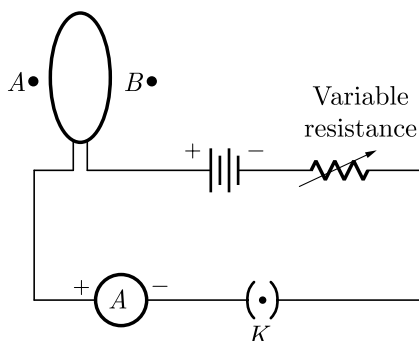

(a) A

(b) B

(c) A if the current is small, and B if the current is large

(d) B if the current is small and A if the current is large.

10. Arrange the following in the increasing order of pH values according to given pH scale.



A. NaOH solution

B. Blood

C. Lemon juice

D. Milk of magnesia

(a) $C < B < D < A$

(b) $A < B < C < D$

(c) $D < C < B < A$

(d) $A < B < D < C$

Continue on next page.....

Click the Following Button to See the Free MS/Solutions

SOLUTIONS

11. Hence, number of electrons passing through a cross section of the filament in 16 seconds would be 10^{20} . A metal is treated with dilute sulphuric acid. The gas evolved is collected by the method shown in the figure.

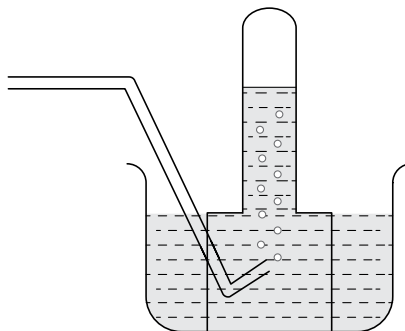

The name of the gas is

- (a) Hydrogen
 - (b) Oxygen
 - (c) Nitrogen
 - (d) Helium
12. Which statement is not true about thyroxin ?
- (a) Iron is essential for the synthesis of thyroxin
 - (b) It regulates carbohydrates, protein and fat metabolism in the body
 - (c) Thyroid gland requires iodine to synthesise thyroxin
 - (d) Thyroxin is also called thyroid hormone.
13. During adolescence, several changes occur in the human body. Mark one change associated with maturation in boys
- (a) loss of milk teeth
 - (b) increase in height
 - (c) cracking of voice
 - (d) weight gain
- 14.

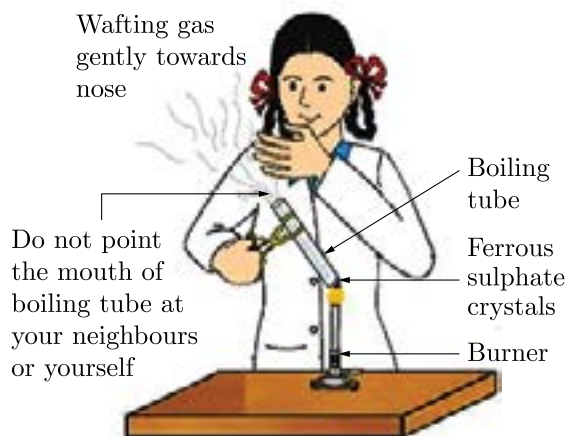

Continue on next page.....

Click the Following Button to See the Free MS/Solutions

SOLUTIONS

The colour of the crystals before heating and after heating are respectively:

- (a) Pale green, Reddish brown
- (b) Reddish brown, Pale green
- (c) Reddish brown, Reddish brown
- (d) Pale green, Pale green

15. Identify the circuit (Figure) in which the electrical components have been properly connected.

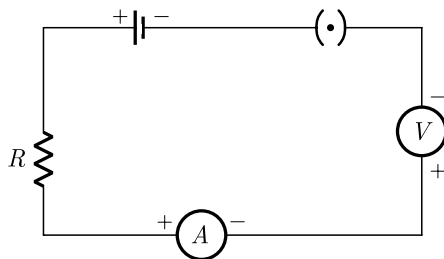

(i)

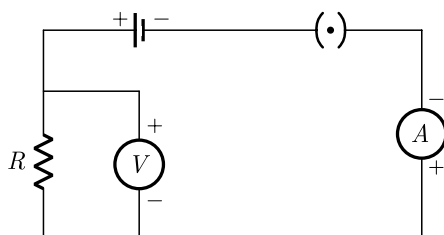

(ii)

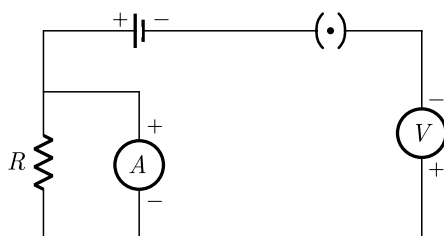

(iii)

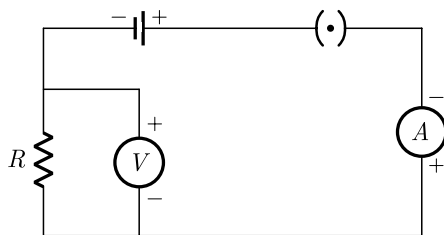

(iv)

- (a) (i)
- (b) (ii)
- (c) (iii)
- (d) (iv)

Continue on next page.....

Click the Following Button to See the Free MS/Solutions

SOLUTIONS

16. Which of the following are correctly matched in the given table?

1.	Dissolution	Solute gets dissolved in a solvent.
2.	Exothermic	Heat is absorbed.
3.	Reversible change	Reactants can be obtained.

- (a) 1 and 2
- (b) 2 and 3
- (c) 1 and 3
- (d) 1, 2 and 3

Question no. 17 to 20 are Assertion-Reasoning based questions.

17. **Assertion :** Equation

$C(s) + O_2(g) \longrightarrow CO_2(g)$ is an example of combination reaction.

Reason : In the given above equation, carbon and oxygen react to give carbon dioxide.

- (a) Both Assertion and Reason are True and Reason is the correct explanation of the Assertion.
- (b) Both Assertion and Reason are True but Reason is not the Correct explanation of the Assertion.
- (c) Assertion is True but the Reason is False.
- (d) Both Assertion and Reason are False.

18. **Assertion :** Changes in non-reproductive tissues can be passed on the DNA of the germ cells.

Reason : Inherited traits include the traits developed during the lifetime of an individual that cannot be passed on to its progeny.

- (a) Both assertion (A) and reason (R) are true and reason (R) is the correct explanation of assertion (A).
- (b) Both assertion (A) and reason (R) are true but reason (R) is not the correct explanation of assertion (A).
- (c) Assertion (A) is true but reason (R) is false.
- (d) Assertion (A) is false but reason (R) is true.

19. **Assertion :** The thickest muscles are present in left atrium.

Reason : Left atrium receives deoxygenated blood from the lungs.

- (a) Both Assertion and Reason are true and Reason is the correct explanation of Assertion.
- (b) Both Assertion and Reason are true but Reason is not the correct explanation of Assertion.
- (c) Assertion is true but Reason is false.
- (d) Both Assertion and Reason are false.

20. **Assertion :** A direction current flows through a metallic rod, produced magnetic field only outside the rod.

Reason : There is no flow of charge carriers inside the rod.

- (a) Both assertion (A) and reason (R) are true and reason (R) is the correct explanation of assertion (A).
- (b) Both assertion (A) and reason (R) are true but reason (R) is not the correct explanation of assertion (A).
- (c) Assertion (A) is true but reason (R) is false.
- (d) Assertion (A) is false but reason (R) is true.

Click the Following Button to See the Free MS/Solutions

SOLUTIONS

SECTION-B

Question no. 21 to 26 are very short answer questions.

21. Define the term 'electrical conductivity' of metals. Arrange the following metals in order of their decreasing electrical conductivity :

or

Give reasons for the following :

- (a) We can store copper sulphate solution in silver vessel but not silver nitrate solution in a copper vessel.
 (b) Food cans are coated with tin rather than zinc.
22. Lack of oxygen in muscles often leads to cramps among cricketers. Explain why?
23. During one cycle how many times blood goes to heart of fish and why ?
24. What are the functions of bicuspid and tricuspid valves in human heart ?
25. Mention the factor on which scattering of light depends. Why does the sky appear dark in space ?

or

No rainbow could be observed from the surface of the moon by the astronauts. Give reason.

26. Aquarium need to be cleaned once in a while whereas ponds or lakes do not require any cleaning; Explain

SECTION-C

Question no. 27 to 33 are short answer questions.

27. Justify with the help of an example that displacement reaction is also a redox reaction.
28. Give reasons for the following :
- (a) Ionic compounds in general have high melting and boiling points.
 (b) Highly reactive metals cannot be obtained from their oxides by heating them with carbon.
 (c) Copper containers get a green coat when left exposed to air in the rainy season.
29. State the functions of the following in the alimentary canal :
- (i) Liver
 (ii) Gall bladder
 (iii) Villi.

or

- (a) In the process of respiration, state the function of alveoli.
 (b) Rate of breathing in aquatic, organisms is much faster than that in terrestrial organisms. Give reasons.
 (c) Complete the following pathway showing the breakdown of glucose :

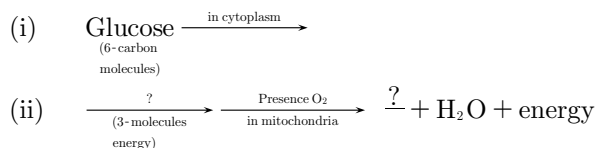

Continue on next page.....

Click the Following Button to See the Free MS/Solutions

SOLUTIONS

30. Name the type of mirror used in the following situations and support your answer with a reason :
- Mirror used for shaving.
 - Mirror used by ENT doctors.
 - Mirror used in the vehicles for viewing the traffic approaching from behind.
31. (a) A divergent lens has focal length of 20 cm. At what distance should the object from the lens be placed so that an image is formed 10 cm away from the lens ? What is the magnification produced, by the lens ?
- (b) Draw a ray diagram to show the position and nature of the image formed by a convex lens when an object is placed between optical centre and focus of the lens.
32. (i) What is the function of earth wire in electrical instruments?
- (ii) Explain what is short circuiting an electric supply.
- (iii) What is the usual current rating of the fuse wire in the line to feed
- Lights and fans?
 - Appliances of 2kW or more power?
- or**
- Which effect of the electric current is utilised in the working of an electrical fuse ?
 - Is a fuse connected in series or in parallel in household circuit ?
 - Draw a schematic labelled diagram of a domestic circuit which has a provision of a main fuse, meter, one light bulb and a switch/socket.
33. Differentiate autotrophs heterotrophs and decomposer and give one example of each.

SECTION-D

Question no. 34 to 36 are Long answer questions.

34. Complete the following reactions :

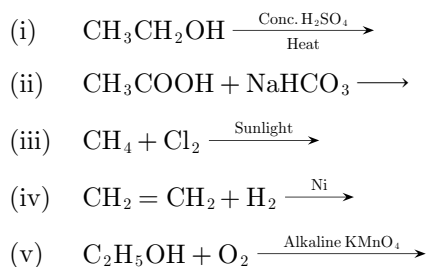

or

- What is a catalyst ? Write the chemical equation to represent the hydrogenation of ethene.
 - Which of the following compounds belong to the same homologous series ?
 C_2H_6 , $\text{C}_2\text{H}_6\text{O}_2$, $\text{C}_2\text{H}_6\text{O}$, C_4H_{10}
35. (a) Draw a diagram to show spore formation in Rhizopus.
- (b) With the help of an example differentiate between the process of Budding and Fragmentation.
- (c) Why is vegetative propagation practiced for growing some type of plants?
- or**
- Draw a neat labelled diagram of pistil showing germination of pollen on stigma.
 - Give the functions of :
 - Stigma
 - Ovary
 - State in brief the formation of seed in a flower.

Click the Following Button to See the Free MS/Solutions

SOLUTIONS

36. Inside the house, connections to all the devices are made in parallel, each having independent switch and fuse (if necessary). Thus, whenever some fault occurs in circuit of one particular device in one room, devices in other rooms do not suffer.

Figure shows a 240V AC mains circuit to which a number of appliances are connected and switched on.

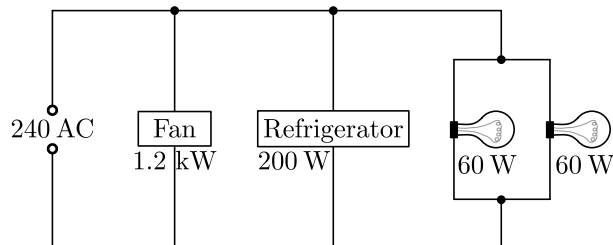

- Calculate the power supplied to the circuit.
- Find out the value of electric current in the refrigerators.
- Calculate energy used by the fan in 2 hours.
- Calculate resistance of the filament of one lamp.

SECTION-E

Question no. 37 to 39 are case-based/data -based questions with 2 to 3 short sub-parts. Internal choice is provided in one of these sub-parts.

37. Some reaction of metal with some compounds are given in the table:

Metal	Iron (II) Sulphate	Copper (II) Sulphate	Zinc Sulphate	Silver Nitrate
<i>A</i>	No reaction	Displacement	---	---
<i>B</i>	Displacement	---	No reaction	---
<i>C</i>	No reaction	No reaction	No reaction	Displacement
<i>D</i>	No reaction	No reaction	No reaction	No reaction

- Name the most and least active metal.
 - Arrange the metals *A*, *B*, *C* and *D* in order of increasing reactivity.
- or**
- Container of which metal can be used to store both zinc sulphate solution and silver nitrate solution?
38. To carry out a simple function such as eating food there has to be coordination of the eyes, hands and the mouth. The eyes have to focus on the food, the hands have to pick it up and take it to the mouth where it will be chewed. All these actions have to be coordinated in such a manner that they follow a particular sequence and the action is completed. A similar mechanism is also needed for internal functions of the body. This function is carried out by the nervous system.
It is composed of :
- specialised cells which can detect, receive and transmit different kinds of stimuli. These are called neurons.
 - nerve fibres which are certain bundles of extended processes of nerve cells.

Continue on next page.....

Click the Following Button to See the Free MS/Solutions

SOLUTIONS

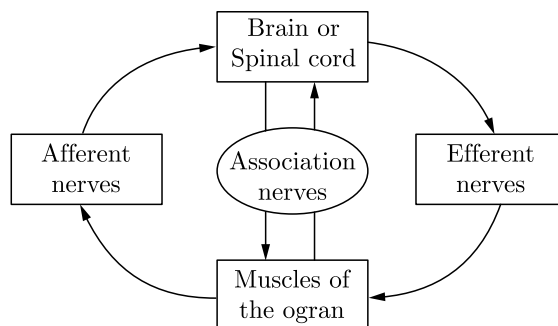

The individuals also have to adjust to the changing conditions of the body should vary their responses. At the same time, the internal conditions of the body should be maintained constant. This is called homeostasis. The internal conditions of the body are maintained at a constant by controlling the physiology of the organisms.

- (i) What will the correct sequence in which conduction of information through nerves take place?
- (ii) How homeostasis is said to maintain the equilibrium of the body?
- (iii) What function does the central nervous system perform?

or

- (iv) What happens when the dendrite tip of a nerve cell receives a signal?

39. “Change in path of a light ray as it passes from one medium to another medium is called refraction of light.”

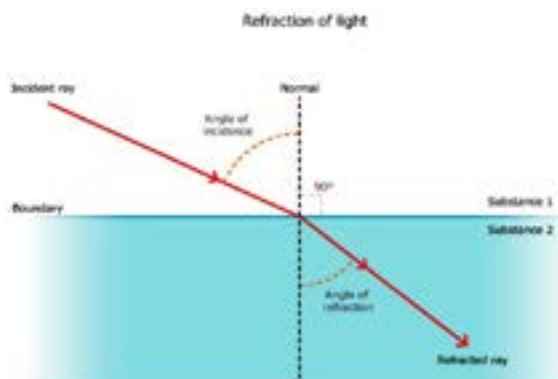

When light travels from a rarer medium to a denser one, it bends towards the normal ($i > r$) and when travels from a denser medium to a rarer one, it bends away from the normal ($i < r$).

Where, i = Angle of incidence

and r = Angle of refraction

We can see refraction in our daily life, some of the examples are given below :

The bottom of a tank or pond containing water appears to be raised due to refraction of light which takes place when light rays pass from the pool of water into the air. The letters appear to be raised when viewed through a glass slab placed over the document because of refraction of light.

When a light ray enters in a glass slab, then the emergent ray is parallel to the incident ray but it is shifted sideward slightly.

In this case, refraction takes place twice, first when ray enters glass slab from air and second when exits from glass slab to air.

- (i) What do you mean by optically rarer and denser medium ?
- (ii) What is the cause of refraction ?
- (iii) Draw a ray diagram showing refraction through a glass slab.

or

- (iv) Give one example of refraction from our daily life experience other than the two examples given above.

□□□□□□

Click the Following Button to See the Free MS/Solutions

SOLUTIONS

Sample Paper 21

Class X 2023-24

Science (086)

Time: 3 Hours

Max. Marks: 80

General Instructions:

1. This question paper consists of 39 questions in 5 sections.
 2. All questions are compulsory. However, an internal choice is provided in some questions. A student is expected to attempt only one of these questions.
 3. Section A consists of 20 Objective Type questions carrying 1 mark each.
 4. Section B consists of 6 Very Short questions carrying 02 marks each. Answers to these questions should be in the range of 30 to 50 words.
 5. Section C consists of 7 Short Answer type questions carrying 03 marks each. Answers to these questions should be in the range of 50 to 80 words.
 6. Section D consists of 3 Long Answer type questions carrying 05 marks each. Answer to these questions should be in the range of 80 to 120 words.
 7. Section E consists of 3 source-based/case-based units of assessment of 04 marks each with sub-parts.
-

SECTION-A

Select and write one most appropriate option out of the four options given for each of the questions 1 – 20.

1. In a neuron, conversion of electrical signal to a chemical signal occurs at in

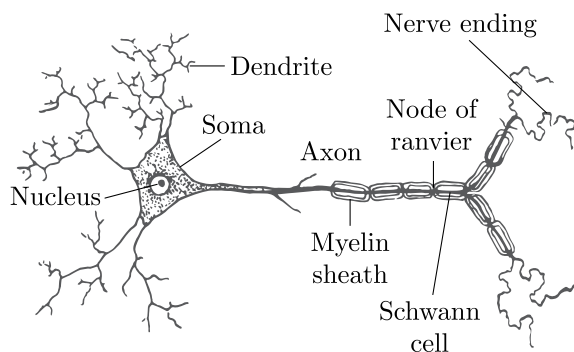

- (a) cell body
 - (b) axonal end
 - (c) dendritic end
 - (d) axon
2. The maintenance functions of living organisms must go on even when they are not doing
- (a) Anything particular
 - (b) Sleeping
 - (c) Moving at constant speed
 - (d) Hibernation

Continue on next page.....

Click the Following Button to See the Free MS/Solutions

SOLUTIONS

3. The soap molecule has a
- hydrophilic head and a hydrophobic tail
 - hydrophobic head and a hydrophilic tail
 - hydrophobic head and a hydrophobic tail
 - hydrophilic head and a hydrophilic tail
4. Advanced sunrise and delayed sunset are explained on the basis of
- Tyndall effect
 - scattering of light
 - dispersion of light
 - atmospheric refraction

5. Which of the following are correctly matched in the given table?

1.	Acid + salt	metal + hydrogen
2.	Acid + metal carbonate	salt + carbon dioxide + water
3.	Metal oxide + acid	salt + water

- 1 and 2
 - 2 and 3
 - 1 and 3
 - 1, 2 and 3
6. Which of the following statement for chromosomal theory of inheritance is incorrect?
- Pairing and separation of a pair of the chromosomes would lead to segregation of a factor they carried.
 - Behaviour of chromosomes is parallel to the behaviour of genes.
 - The two alleles of a gene pair are located on homologous sites on homologous chromosomes.
 - Chromosomes as well as genes occur in pair
7. Which one of the following is the example of oxidation?
- $2\text{Mg}(s) + \text{O}_2(g) \xrightarrow{\text{Burning}} 2\text{MgO}(s)$
 - $\text{CuO}(s) + \text{H}_2(g) \xrightarrow{\text{Heat}} \text{Cu}(s) + \text{H}_2\text{O}(g)$
 - $\text{Fe}_2\text{O}_3(s) + 2\text{Al}(s) \longrightarrow \text{Al}_2\text{O}_3(s) + 2\text{Fe}(s)$
 - None of these
8. Which among the following is (are) double displacement reaction(s)?
- $\text{Pb} + \text{CuCl}_2 \longrightarrow \text{PbCl}_2 + \text{Cu}$
 - $\text{Na}_2\text{SO}_4 + \text{BaCl}_2 \longrightarrow \text{BaSO}_4 + 2\text{NaCl}$
 - $\text{C} + \text{O}_2 \longrightarrow \text{CO}_2$
 - $\text{CH}_4 + 2\text{O}_2 \longrightarrow \text{CO}_2 + 2\text{H}_2\text{O}$
- 1 and 4
 - Only 2
 - 1 and 2
 - 3 and 4

Continue on next page.....

Click the Following Button to See the Free MS/Solutions

SOLUTIONS

9. Which of the following ray diagrams is correct for the ray of light incident on a lens shown in Figure?

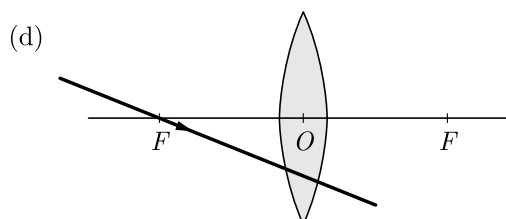
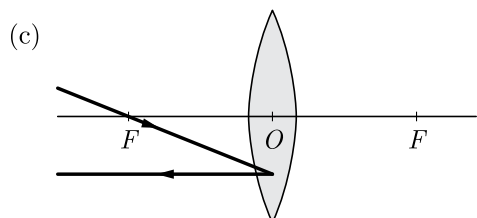
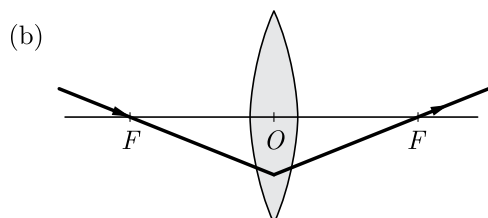
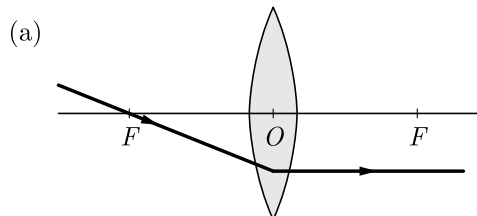
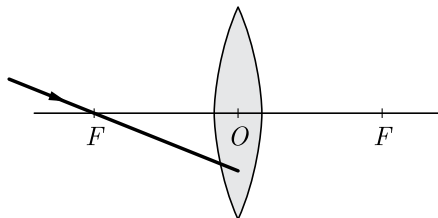

10. The reaction $2\text{Na} + \text{Cl}_2 \longrightarrow 2\text{NaCl}$ is an example of
- combination reaction
 - decomposition reaction
 - displacement reaction
 - double displacement reaction

Continue on next page.....

Click the Following Button to See the Free MS/Solutions

SOLUTIONS

11. The table shows the characteristics of blood in one blood vessel of the body.

Oxygen concentration	Carbon dioxide concentration	Pressure
High	Low	High

Which blood vessel contains blood with these characteristics?

- (a) Vena cava
 (b) Pulmonary vein
 (c) Aorta
 (d) Pulmonary artery
12. In the list of organisms given below, those that reproduce by the asexual method are
- (i) Banana
 (ii) Dog
 (iii) Yeast
 (iv) Amoeba
- (a) (ii) and (iv)
 (b) (i), (iii) and (iv)
 (c) (i) and (iv)
 (d) (ii), (iii) and (iv)

13. A solution turns red litmus blue, its pH is likely to be



- (a) 1
 (b) 4
 (c) 5
 (d) 10
- 14.

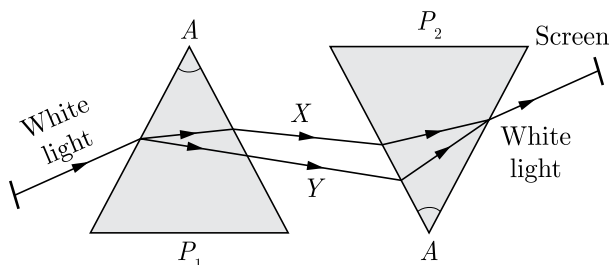

Here X and Y indicates:

- (a) Green colour, violet colour
 (b) Red colour, violet colour
 (c) Violet colour, red colour
 (d) Green colour, red colour

Continue on next page.....

Click the Following Button to See the Free MS/Solutions

SOLUTIONS

15. A child standing in front of a magic mirror. She finds the image of her head bigger, the middle portion of her body of the same size and that of the legs smaller. The following is the order of combinations for the magic mirror from the top.



- (a) Plane, convex and concave
 (b) Convex, concave and plane
 (c) Concave, plane and convex
 (d) Convex, plane and concave
16. Generally metals react with acids to give salt and hydrogen gas.

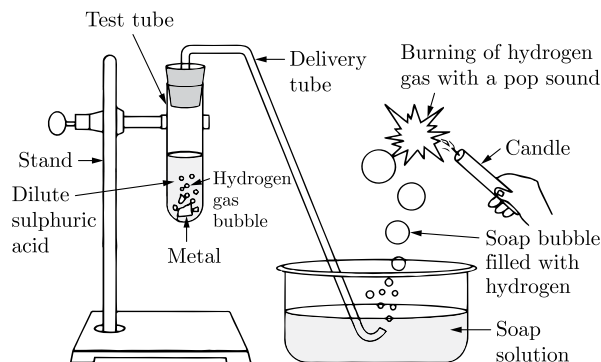

Which of the following acids does not give hydrogen gas on reacting with metals (except Mn and Mg)?

- (a) H_2SO_4
 (b) HCl
 (c) HNO_3
 (d) All of these

Question no. 17 to 20 are Assertion-Reasoning based questions.

17. **Assertion :** The following chemical equation,



is a balanced chemical equation.

Reason : In a balanced chemical equation, the total number of atoms of each element may or may not equal on both side of the equation.

- (a) Both Assertion and Reason are True and Reason is the correct explanation of the Assertion.
 (b) Both Assertion and Reason are True but Reason is not the Correct explanation of the Assertion.
 (c) Assertion is True but the Reason is False.
 (d) Both Assertion and Reason are False.

Click the Following Button to See the Free MS/Solutions

SOLUTIONS

18. **Assertion :** Units which make up the nervous system are called neurons.
Reason : Nerve impulses are carried by dendrites towards the cell body.
- Both assertion (A) and reason (R) are true and reason (R) is the correct explanation of assertion (A).
 - Both assertion (A) and reason (R) are true but reason (R) is not the correct explanation of assertion (A).
 - Assertion (A) is true but reason (R) is false.
 - Assertion (A) is false but reason (R) is true.
19. **Assertion :** Excretion is the biological process by which harmful wastes are removed from an organism's body.
Reason : The mode of excretion is completely same in both unicellular and multicellular organisms.
- Both Assertion and Reason are true and Reason is the correct explanation of Assertion.
 - Both Assertion and Reason are true but Reason is not the correct explanation of Assertion.
 - Assertion is true but Reason is false.
 - Assertion is false but Reason is true.
20. **Assertion :** All electric devices shown in the circuit are ideal. The reading of each of ammeter (A) and voltmeter (V) is zero.

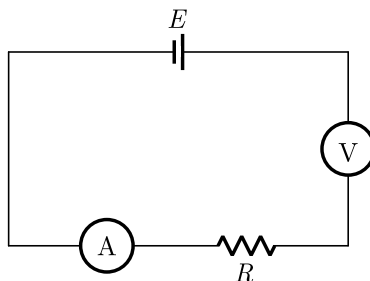

Reason : An ideal voltmeter draws almost no current due to very large resistance, and hence (V) and (A) will read zero.

- Both assertion (A) and reason (R) are true and reason (R) is the correct explanation of assertion (A).
- Both assertion (A) and reason (R) are true but reason (R) is not the correct explanation of assertion (A).
- Assertion (A) is true but reason (R) is false.
- Assertion (A) is false but reason (R) is true.

SECTION-B

Question no. 21 to 26 are very short answer questions.

21. Metal oxides are basic in nature. But some metal oxides show both acidic as well as basic behaviour. What are these oxides called ? Name one such oxide and write the reaction with an acid and a base.

or

Aluminium occurs in combined state whereas gold is found in free state. Why ?

22. What name is given to the movement of a plant in the direction of stimulus ? Give any three examples.

Continue on next page.....

Click the Following Button to See the Free MS/Solutions

SOLUTIONS

23. How do proteins control the characteristics that are inherited ? Explain with the help of an example.
24. What are sexually transmitted diseases? Name few of them.
25. An object is placed at a distance of 40 cm in front of a convex mirror of radius of curvature 40 cm. List four characteristics of the image formed by the mirror.

or

An object is 2 m away from a lens, which forms an erect image one-fourth the size of the object. Determine the focal length of the lens. What type of lens is this ?

26. Observe the food chain :

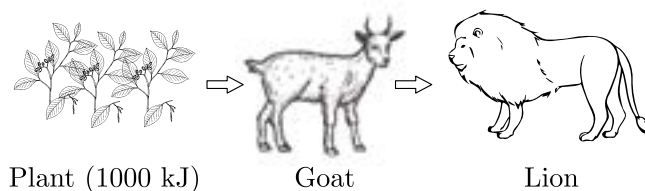

- (a) If autotrophs occupying the first trophic level are called producers, what are herbivores called as ?
- (b) How much energy does the lion get in the above food chain ?

SECTION-C

Question no. 27 to 33 are short answer questions.

27. What is an oxidizing agent ? What happens when an oxidizing agent is added to propanol ? Explain with the help of a chemical equation.
28. In an experiment 20 g of zinc (A) was reacted with 20 g of iodine (B) in a 250 ml beaker containing 50 ml water. Reaction proceeded with evolution of heat and at the end, reaction mixture did not give any colour on adding starch solution, but some zinc was found settling at the bottom.
- $$\text{Zn(s)} + \text{I}_2(\text{s}) \rightarrow \text{ZnI}_2(\text{s}) + \text{heat}$$
- (i) Is the reaction endothermic or exothermic ?
- (ii) Out of the two reactants, Zn(s) and I₂(s), which one is left unreacted ? Why?
- (iii) How much of (A) and (B) should be taken so that no reactant is left out at the end of the reaction ?
29. Name the types of sex chromosomes present in
- (i) human male and
- (ii) human female.
- What will be the sex of the child produced if a sperm carrying Y-chromosome fertilizes the egg ? Name an insect in which similar type of sex determination takes place.

or

In humans, genetically the sex of a child is determined by the father and not by the mother. Explain.

Continue on next page.....

Click the Following Button to See the Free MS/Solutions

SOLUTIONS

30. A person cannot see clearly objects beyond a distance of 1.2 m. Name the defect of vision he is suffering from. What would be the power of correcting lens used to restore proper vision ?
31. A child is able to read his book comfortably but is unable to read the matter written on the blackboard at certain distance.
- Name the defect of vision he is suffering from.
 - With the help of labelled ray diagram show :
 - The above mentioned defect of vision.
 - Correction of the above mentioned defect using a suitable lens.
32. While studying the dependence of potential difference V across a resistor on the current I passing through it, in order to determine the resistance of the resistor, a student took 5 readings for different values of current and plotted a graph between V and I . He got a straight line graph passing through the origin. What does the straight line signify? Write the method of determining resistance of the resistor using this graph.
- or**
- A wire of resistance $6\ \Omega$ is bent to form a closed square. What is the resistance across a diagonal of the square ?
33. (a) What is the difference between self-pollination and cross-pollination ?
(b) What happens to the pollen which falls on a suitable stigma ? Explain.

SECTION-D

Question no. 34 to 36 are Long answer questions.

34. (a) Compare soaps and detergents on the basis of their composition and cleansing action in hard water.
(b) What happens when ethanol is treated with sodium metal? State the behaviour of ethanol in this reaction.
(c) Draw the structure of cyclohexane.
(d) Name the following compound.

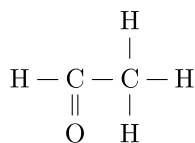

or

- Design an activity to show the conditions needed for iron nails to rust.
 - Why do we apply paint on iron articles ?
35. Differentiate between :
- Plumule and radicle
 - Pollination and fertilization

or

Answer the following questions :

- What happens if an egg is not fertilized?
- Why do we need to adopt contraceptive measures?
- Name one bacterial and one viral sexually transmitted disease.

Continue on next page.....

Click the Following Button to See the Free MS/Solutions

SOLUTIONS

36. (a) List two disadvantages of using a series circuit in homes.
 (b) Calculate the effective resistance between A and B in the circuit given below:

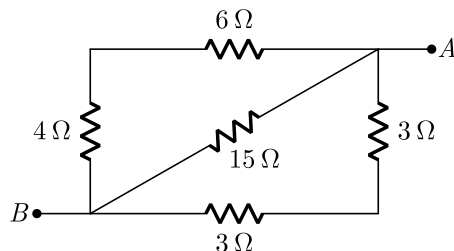

SECTION-E

Question no. 37 to 39 are case-based/data-based questions with 2 to 3 short sub-parts. Internal choice is provided in one of these sub-parts.

37. A metal carbonate X on heating with an acid gives a gas which when passed through a solution Y gives the carbonate back. On the other hand, a gas G that is obtained at anode during electrolysis of brine is passed on dry Y , it gives a compound Z , used for disinfecting drinking water.
- Identify X , Y , G and Z .
 - What is the nature of the gas evolved when X is heated ?
 - Write the reaction involved in the formation of G ?
- or**
- Write the reaction involved when G reacts with Y .

38. The thyroid is a small, butterfly-shaped gland located at the base of your neck just below the Adam's apple. It is part of an intricate network of glands called the endocrine system. The endocrine system is responsible for coordinating many of your body's activities. The thyroid gland manufactures hormones that regulate your body's metabolism.

Several different disorders can arise when your thyroid produces too much hormone (hyperthyroidism) or not enough (hypothyroidism). Four common disorders of the thyroid are Hashimoto's disease, Graves' disease, goitre and thyroid nodules.

In hyperthyroidism, the thyroid gland is overactive. It produces too much of its hormone. Hyperthyroidism affects about 1 percent of women. It's less common in men.

Graves' disease is the most common cause of hyperthyroidism, affecting about 70 percent of people with an overactive thyroid. Nodules on the thyroid – a condition called toxic nodular goitre or multinodular goitre can also cause the gland to overproduce its hormones.

Excessive thyroid hormone production leads to symptoms such as : restlessness nervousness, racing heart, irritability, increased sweating, shaking, anxiety, trouble sleeping, thin skin, brittle hair and nails, muscle weakness, weight loss, bulging eyes (in Graves' disease).

- What is thyroid gland ?
- What is the function of the thyroid gland ?
- Name some common disorders of the thyroid.

or

- Give some symptoms of hyperthyroidism.

Continue on next page.....

Click the Following Button to See the Free MS/Solutions

SOLUTIONS

39. Rajesh’s father Mr. Jayesh runs a cosmetics and perfumes shop in a crowded market place. Mr. Jayesh i usually complains at home that there is lot of ‘shop-lifting’ in his shop which was causing loss to him. Rajesh used to hear such complaints of his father. One day Rajesh went to the market and purchased one big mirror of a special kind. He then went to his father’s shop and fixed the mirror at strategic positions inside the shop as shown in the figure. Mr. Jayesh found that after the installation of the mirror, the shop-lifting almost stopped. He was very happy and thanked Rajesh for making this possible.



- (i) What type of mirror was fixed by Rajesh in the shop?
- (ii) Place three ticks in the table for image formed by such mirror due to which it helps in preventing shop-lifting.

Diminished	
Inverted	
Real	
Enlarged	
Same size	
Upright	
Virtual	

- (iii) What special name/names is/are given to such mirror which help in preventing shop-lifting?
or
- (iv) After few days that mirror becomes dirty. During cleaning, Rajesh held the mirror inside the water. So, what should be the change in the focal length of the mirror?

□□□□□□

DOWNLOAD INDIA'S BEST STUDY MOBILE APP

- 30 Sample Paper with Solutions
- Chapterwise Question Bank of All Subject
- Previous 15 Years Solved Papers
- NCERT Solutions
- Case Study Questions with full Solutions
- **Word File of Material for Teachers**

Search by **NODIA** on Play Store to Download App
Add 89056 29969 in Your Class Whatsapp Group to Get Link

Click the Following Button to See the Free MS/Solutions

SOLUTIONS

Sample Paper 22

Class X 2023-24

Science (086)

Time: 3 Hours

Max. Marks: 80

General Instructions:

1. This question paper consists of 39 questions in 5 sections.
 2. All questions are compulsory. However, an internal choice is provided in some questions. A student is expected to attempt only one of these questions.
 3. Section A consists of 20 Objective Type questions carrying 1 mark each.
 4. Section B consists of 6 Very Short questions carrying 02 marks each. Answers to these questions should be in the range of 30 to 50 words.
 5. Section C consists of 7 Short Answer type questions carrying 03 marks each. Answers to these questions should be in the range of 50 to 80 words.
 6. Section D consists of 3 Long Answer type questions carrying 05 marks each. Answer to these questions should be in the range of 80 to 120 words.
 7. Section E consists of 3 source-based/case-based units of assessment of 04 marks each with sub-parts.
-

SECTION-A

Select and write one most appropriate option out of the four options given for each of the questions 1 – 20.

1. The strength of magnetic field inside a long current carrying straight solenoid is

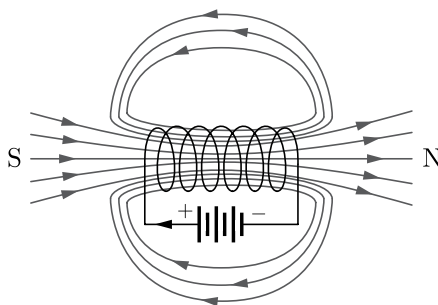

- (a) more at the ends than at the centre
 - (b) minimum in the middle
 - (c) same at all points
 - (d) found to increase from one end to the other
2. Which of the following is the observations of the chemical reaction?
1. Change in state
 2. Evolution of a gas
 3. Change in colour
 4. Change in temperature
- (a) 1, 2 and 3
 - (b) 1, 2 and 4
 - (c) 1, 3 and 4
 - (d) 1, 2, 3 and 4

Click the Following Button to See the Free MS/Solutions

SOLUTIONS

3. A metal M of moderate reactivity is present as its sulphide X . On heating in air, X converts into its oxide Y and a gas evolves. On heating Y and X together, the metal M is produced. X and Y respectively are
- X cuprous sulphide, Y cuprous oxide
 - X cuprous sulphide, Y cupric oxide
 - X sodium sulphide, Y sodium oxide
 - X calcium sulphide, Y calcium oxide
4. Vegetative propagation refers to formation of new plants from
- stem, roots and flowers
 - stem, roots and leaves
 - stem, flowers and fruits
 - stem, leaves and flowers
5. A graph was plotted to show the energy output of two types of respiration. Identify the type of respiration denoted by curves A and B .

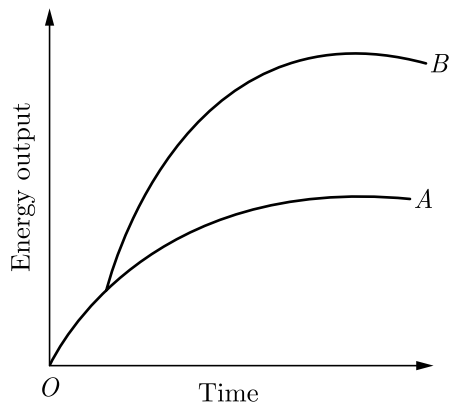

- Anaerobic respiration, Aerobic respiration
 - Aerobic respiration, Anaerobic respiration
 - Aerobic respiration, Aerobic respiration
 - Anaerobic respiration, Anaerobic respiration
6. Transpiration helps :
- in the absorption
 - in the upward movement of water minerals dissolved in it from roots to the leaves
 - in temperature regulation
 - all of the above

Continue on next page.....

Click the Following Button to See the Free MS/Solutions

SOLUTIONS

7. V - I graph for the two wires A and B are shown in the figure. If we connect both the wires one by one to the same battery which of the two will produce more heat per unit time ?

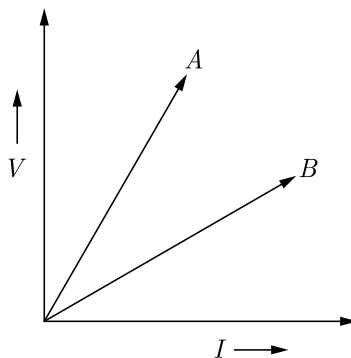

- (a) A
 (b) B
 (c) Both A and B
 (d) None of these
8. Which of the following the father of genetics ?
 (a) Mendel
 (b) Hook
 (c) Faraday
 (d) Newton
9. What is the maximum resistance which can be made using five resistors each of $1/5 \Omega$?
 (a) $1/5 \Omega$
 (b) 10Ω
 (c) 5Ω
 (d) 1Ω
10. Involuntary actions in the body are controlled by
 (a) medulla in fore brain
 (b) medulla in mid brain
 (c) medulla in hind brain
 (d) medulla in spinal cord

11.

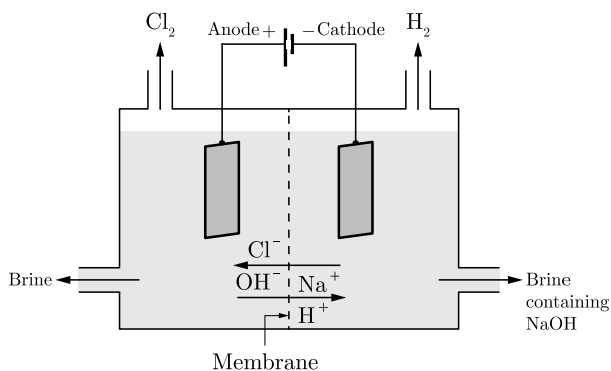

Continue on next page.....

Click the Following Button to See the Free MS/Solutions

SOLUTIONS

Which of the following gases formed at the anode and the cathode?

- (a) Chlorine, Hydrogen
 - (b) Hydrogen, Chlorine
 - (c) Hydrogen, Hydrogen
 - (d) Chlorine, Chlorine
12. In the double displacement reaction between aqueous potassium iodide and aqueous lead nitrate, a yellow precipitate of lead iodide is formed. While performing the activity if lead nitrate is not available, which of the following can be used in place of lead nitrate?
- (a) Lead sulphate (insoluble)
 - (b) Lead acetate
 - (c) Ammonium nitrate
 - (d) Potassium sulphate
13. Which of the following statements is true for acids?
- (a) Bitter and change red litmus to blue
 - (b) Sour and change red litmus to blue
 - (c) Sour and change blue litmus to red
 - (d) Bitter and change blue litmus to red
14. Hard water is not available for an experiment in the school and its vicinity. However, some salts as given below are available in the school laboratory.
1. Sodium Chloride
 2. Sodium Sulphate
 3. Calcium Chloride
 4. Calcium Sulphate
 5. Potassium Chloride
 6. Magnesium Sulphate
- Select form the following a group of these salts, each member of which may be dissolved in water to make it hard.
- (a) 1, 2, 5
 - (b) 1, 3, 5
 - (c) 3, 4, 6
 - (d) 2, 4, 6
15. The strength of magnetic field around a current carrying conductor is

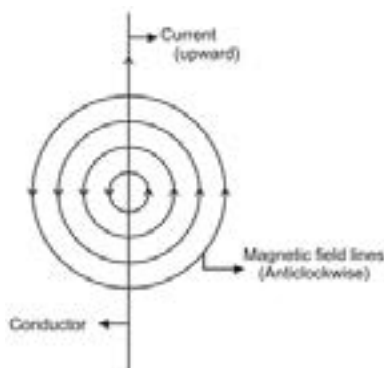

Continue on next page.....

Click the Following Button to See the Free MS/Solutions

SOLUTIONS

SECTION-B

Question no. 21 to 26 are very short answer questions.

21. What is meant by galvanisation ? Why is it done ?

or

Why do ionic compounds conduct electricity in molten state ?

22. State the function of Bowman's Capsule and glomerulus.

23. State the necessary conditions of autotrophic nutrition and name the by product. Mention the source of this by product.

24. In winter the frequency of urination is more. Why ?

25. Why does the colour of the sky appear blue ? Explain in brief.

or

What type of spectacles should be worn by a person having the defects of myopia as well as hypermetropia? How does it help ?

26. If a lake is contaminated with pesticides, which one of the following organisms will contain in its body the maximum concentration of pesticides and why ?

Small fish, Pelicans, Zooplanktons, Phytoplanktons, Big fish.

SECTION-C

Question no. 27 to 33 are short answer questions.

27. When hydrogen sulphide gas is passed through a blue solution of copper sulphate, the colour of the solution fades and a black precipitate is obtained.

- (a) Name the type of reaction mentioned above.
- (b) Why does the colour of the solution fade away ?
- (c) Write the chemical name of the black precipitate formed.

28. (a) Arrange the metals Zn, Mg, Al, Cu and Fe in decreasing order of reactivity.

- (b) What would you observe when you put
 - (i) Some zinc pieces into blue copper sulphate solution ?
 - (ii) Some copper pieces into green ferrous sulphate solution.
- (c) Name a metal which combines with hydrogen gas. Name the compound formed.

29. (a) Blood pressure is high in the arteries and low in the veins. Give the possible reason for such difference.

- (b) What is the major cause of high blood pressure ?
- (c) What may happen if a person is having a very high blood pressure ?

or

(i) Name the following :

- (a) The three carbon molecule that is formed due to break-down of glucose during respiration.
 - (b) The nitrogenous waste that is removed from the blood in our Kidneys.
- (ii) How do unicellular organisms generally remove waste ?

Click the Following Button to See the Free MS/Solutions

SOLUTIONS

30. A mirror is fitted in a wall of the AGRA FORT. When you stand at a proper location, a full-size image of the Taj Mahal can be seen in this mirror.
- What kind of mirror is it ?
 - Draw a ray diagram for such a mirror when the object is at infinity.
31. You are given a convex lens of focal length 10 cm. Where will you place an object to get a real, inverted and highly enlarged image of the object. Draw a ray diagram.
32. Answer the following questions :
- What is the direction of magnetic field lines outside a bar-magnet ?
 - What is the SI unit of magnetic field ?
 - What does crowding of magnetic field lines indicate ?

or

Study the diagram given below and answer the questions that follow :

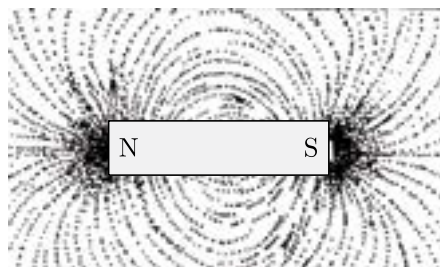

- Why do the iron filings arrange in such a pattern?
 - What does this pattern demonstrate ?
 - Why do the iron filings near the bar magnet seem to align in the shape of closed curves ?
33. How will you create an artificial aquatic ecosystem, which is self-sustainable?

SECTION-D

Question no. 34 to 36 are Long answer questions.

34. (a) Write the molecular formula of an organic compound having its name suffixed with ‘-ol’ and having two carbon atoms in the molecule.
With the help of balanced chemical equation indicate what happens when it is heated with excess of concentrated H_2SO_4 .
- (b) Write names of the following compounds :
- HCOOH
 - $\text{CH}_2\text{COCH}_2\text{CH}_3$.
- (c) Explain why carbon generally forms compounds by covalent bonds.
- or**
- Define catenation. Why no other element exhibits the properties of catenation to the extent seen in carbon compounds ?
 - Name the type of compound formed by the reaction of an organic acid and an alcohol. Write the chemical equation for the reaction involved.

Continue on next page.....

Click the Following Button to See the Free MS/Solutions

SOLUTIONS

35. (a) Draw the diagram of female reproductive system and match and mark the part(s) :
- Where block is created surgically to prevent fertilization.
 - Where Copper-T is inserted?
 - Inside which condom can be placed.
- (b) Why do more and more people prefer to use condoms? What is the principle behind use of condoms?

or

What are the three categories of contraceptive methods? Write briefly about each.

36. (a) What is meant by the statement, “The resistance of a conductor is one ohm”?
- (b) Define electric power. Write an expression relating electric power, potential difference and resistance.
- (c) How many $132\ \Omega$ resistors in parallel are required to carry 5 A on a 220 V line?

SECTION-E

Question no. 37 to 39 are case-based/data-based questions with 2 to 3 short sub-parts. Internal choice is provided in one of these sub-parts.

37. Activity series : Relative reactivities of metals

Potassium		Most reactive
Sodium		
Calcium		
Magnesium		
Aluminium		
Zinc		Reactivity decreases
Iron		
Lead		
Hydrogen		
Copper		
Mercury		
Silver		
Gold		Least reactive

- What happens when iron nail is added to copper sulphate solution? What is the colour change ?
 - Identify the metal which reacts with very dilute nitric acid to evolve hydrogen gas. Name one more metal not given in the above series which reacts in the same way with dilute nitric acid.
 - Name one important ore of copper with its chemical formula.
 - Which method is used to extract sodium from molten sodium chloride ?
- or**
- Which metal is used in the galvanization of iron ?

38. Nastic movements in plants are not directional movements. They are not dependent on the stimulus and are growth independent. For example, the leaves of a touch me not plant (*Mimosa pudica*), fold up immediately when touched. These kinds of changes occur due to the changes in the amount of water in the leaves. Depending on the quantity, they either swell up or shrink. Plant hormones or phytohormones are responsible for the control and coordination of plants. There are different types of hormones, which affect the growth of a plant. Phytohormones are chemical compounds which are released by stimulated cells. These hormones are diffused around the plant cells. They have a role in the cell division, cell enlargement, cell differentiation, fruit growth, falling of leaves, ripening of fruits, ageing of plants etc.

Continue on next page.....

Click the Following Button to See the Free MS/Solutions

SOLUTIONS



- (i) Name the phenomenon called for the movement in growth of plants.
 - (ii) What do you mean by nastic movement ?
 - (iii) What are the different types of harmonies of plants ?
- or**
- (iv) The plant hormone help in the cell growth at the shoot tips by elongating the cells and help in the growth process is :

39. While dealing with the reflection of light by spherical mirrors, we shall follow a set of sign conventions called the New Cartesian Sign Convention. In this convention, the pole (P) of the mirror is taken as the origin. The principal axis of the mirror is take as the x -axis of the coordinate system. In a spherical mirror, the distance of the object from its pole is called the object distance (u). The distance of the image from the pole of the mirror is called the image distance (v). Magnification produced by a spherical mirror gives the relative extent to which the image of an object is magnified with respect to the object size. It is expressed as the ratio of the height of the image to the height of the object. It is usually represented by the letter (m).

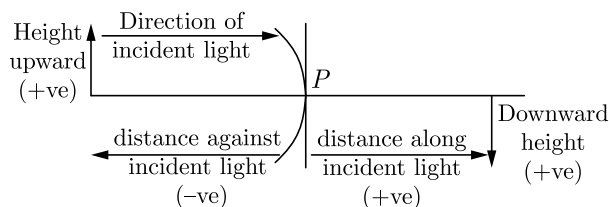

- (i) How can you calculate the magnification of a spherical mirror ?
 - (ii) What does a negative sign in the value of magnification indicates?
 - (iii) Find the focal length of a convex mirror whose radius of curvature is 32 cm.
- or**
- (iv) Why does the height of the object is taken to be positive?

□□□□□□

DOWNLOAD INDIA'S BEST STUDY MOBILE APP

- 30 Sample Paper with Solutions
- Chapterwise Question Bank of All Subject
- Previous 15 Years Solved Papers
- NCERT Solutions
- Case Study Questions with full Solutions
- **Word File of Material for Teachers**

Search by **NODIA** on Play Store to Download App
 Add 89056 29969 in Your Class Whatsapp Group to Get Link

Click the Following Button to See the Free MS/Solutions

SOLUTIONS

Sample Paper 23

Class X 2023-24

Science (086)

Time: 3 Hours

Max. Marks: 80

General Instructions:

1. This question paper consists of 39 questions in 5 sections.
 2. All questions are compulsory. However, an internal choice is provided in some questions. A student is expected to attempt only one of these questions.
 3. Section A consists of 20 Objective Type questions carrying 1 mark each.
 4. Section B consists of 6 Very Short questions carrying 02 marks each. Answers to these questions should be in the range of 30 to 50 words.
 5. Section C consists of 7 Short Answer type questions carrying 03 marks each. Answers to these questions should be in the range of 50 to 80 words.
 6. Section D consists of 3 Long Answer type questions carrying 05 marks each. Answer to these questions should be in the range of 80 to 120 words.
 7. Section E consists of 3 source-based/case-based units of assessment of 04 marks each with sub-parts.
-

SECTION-A

Select and write one most appropriate option out of the four options given for each of the questions 1 – 20.

1. Test tubes *A*, *B* and *C* contain zinc sulphate, silver nitrate and iron (II) sulphate solutions respectively as shown in the figure. Copper pieces are added to each test tubes. Blue colour will appear in case of

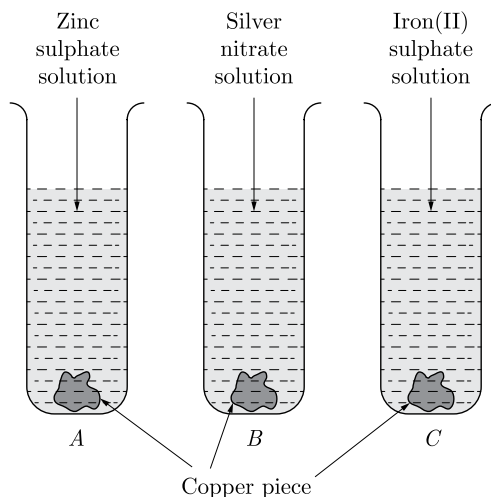

- (a) Test tube *A*
- (b) Test tube *B*
- (c) Test tube *C*
- (d) All the test tube

Continue on next page.....

Click the Following Button to See the Free MS/Solutions

SOLUTIONS

2. The correct electron dot structure of a water molecule is

- (a) $\text{H} \cdot \overset{\cdot\cdot}{\underset{\cdot\cdot}{\text{O}}} \cdot \text{H}$ (b) $\text{H} : \overset{\cdot\cdot}{\underset{\cdot\cdot}{\text{O}}} \cdot \text{H}$
(c) $\text{H} : \overset{\cdot\cdot}{\underset{\cdot\cdot}{\text{O}}} : \text{H}$ (d) $\text{H} : \text{O} : \text{H}$

3. The nature of magnetic field line passing through the centre of current carrying circular loop is



- (a) circular
(b) ellipse
(c) parabolic
(d) straight line
4. Which of the following statements are true about respiration?
A. Haemoglobin has greater affinity for CO_2 than O_2 .
B. The gaseous exchange takes place in the alveoli.
C. During inhalation ribs move inward and diaphragm is raised.
D. Haemoglobin has greater affinity for O_2 than CO_2 .
(a) B and D
(b) A and C
(c) B and C
(d) A and B
5. A soft iron bar is introduced inside the current carrying solenoid as shown in the figure. The magnetic field inside the solenoid

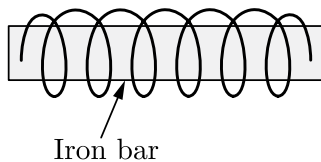

- (a) will decrease
(b) will remain same
(c) will increase
(d) will become zero

Continue on next page.....

Click the Following Button to See the Free MS/Solutions

SOLUTIONS

6. Characters that are transmitted from parents to offspring during reproduction show
- only similarities with parents
 - only variations with parents
 - both similarities and variations with parents
 - neither similarities nor variations
7. Atmospheric nitrogen is converted into organic matter by with plant with the help of
- Bacteria
 - Organic compounds
 - Air born viruses
 - Fertilizers
8. If the current I through a resistor is increased by 100% (assume that temperature remains unchanged), the increase in power dissipated will be
- 100%
 - 200%
 - 300%
 - 400%
9. In an electrical circuit three incandescent bulbs A, B and C of rating 40 W, 60 W and 100 W respectively are connected in parallel to an electric source. Which of the following is likely to happen regarding their brightness ?

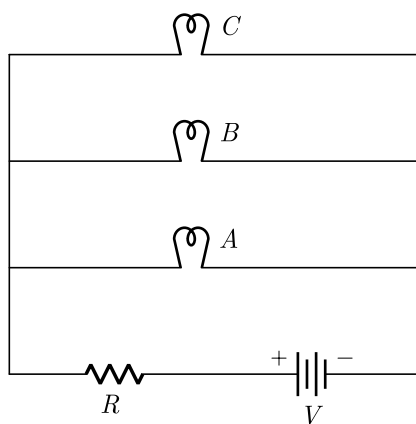

- Brightness of all the bulbs will be the same
 - Brightness of bulb A will be the maximum
 - Brightness of bulb B will be more than that of A
 - Brightness of bulb C will be less than that of B
10. A cross between a tall plant (TT) and short pea plant (tt) resulted in progeny that were all tall plants because
- tallness is the dominant trait
 - shortness is the dominant trait
 - tallness is the recessive trait
 - height of pea plant is not governed by gene 'T' or 't'

Continue on next page.....

Click the Following Button to See the Free MS/Solutions

SOLUTIONS

11. Which of the following statements are true ?
- (i) Sudden action in response to something in the environment is called reflex action.
 - (ii) Sensory neurons carry signals from spinal cord to muscles.
 - (iii) Motor neurons carry signals from receptors to spinal cord.
 - (iv) The path through which signals are transmitted from a receptor to a muscle or a gland is called reflex arc.
- (a) (i) and (ii)
(b) (i) and (iii)
(c) (i) and (iv)
(d) (i), (ii) and (iii)

12.

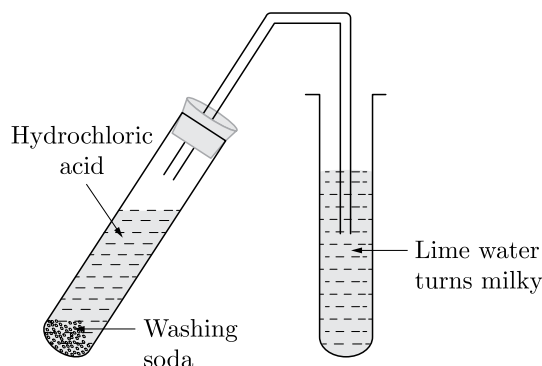

This figure illustrates the reaction of hydrochloric acid with washing soda. Which of the following gas is gas evolved in this experiment?

- (a) Carbon dioxide
(b) Hydrogen
(c) Nitrogen
(d) Helium
13. The physical change is:
- (a) melting of butter
 - (b) burning of paper
 - (c) digestion of food
 - (d) bursting of crackers
14. Translate the following statement into the chemical equation and choose the correct option "Hydrogen gas combines with nitrogen to form ammonia."
- (a) $3\text{H}_2(\text{g}) + \text{N}_2(\text{g}) \longrightarrow 2\text{NH}_3(\text{g})$
 - (b) $\text{H}_2(\text{g}) + \text{N}_2(\text{g}) \longrightarrow \text{NH}_2(\text{g})$
 - (c) $2\text{H}(\text{g}) + \text{N}_2(\text{g}) \longrightarrow 2\text{NH}_3$
 - (d) None of these
15. What happens when dilute hydrochloric acid is added to iron fillings? Tick the correct answer :
- (a) Hydrogen gas and iron chloride are produced.
 - (b) Chlorine gas and iron hydroxide are produced.
 - (c) No reaction takes place.
 - (d) Iron salt and water are produced.

Continue on next page.....

Click the Following Button to See the Free MS/Solutions

SOLUTIONS

16. Action of steam on a metal is shown in the figure.

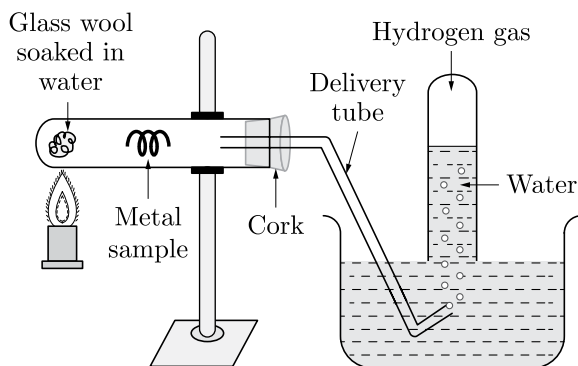

The metal sample in the above experiment is-

- Zinc
- Copper
- Aluminium
- Platinum

Question no. 17 to 20 are Assertion - Reasoning based questions.

17. **Assertion :** Precipitation reactions produce insoluble salts.

Reason : Precipitation reaction is a double decomposition reaction.

- Both Assertion and Reason are True and Reason is the correct explanation of the Assertion.
- Both Assertion and Reason are True but Reason is not the Correct explanation of the Assertion.
- Assertion is True but the Reason is False.
- Both Assertion and Reason are False.

18. **Assertion :** Learning a skill such as dance and music is an acquired trait.

Reason : Acquired traits develops in the life time of an individual and do not pass to the progeny.

- Both assertion (A) and reason (R) are true and reason (R) is the correct explanation of assertion (A).
- Both assertion (A) and reason (R) are true but reason (R) is not the correct explanation of assertion (A).
- Assertion (A) is true but reason (R) is false.
- Assertion (A) is false but reason (R) is true.

19. **Assertion :** Dark phase reactions take place at night.

Reason : Dark phase is independent of light, hence, called light independent phase.

- Both Assertion and Reason are true and Reason is the correct explanation of Assertion.
- Both Assertion and Reason are true but Reason is not the correct explanation of Assertion.
- Assertion is true but Reason is false.
- Both Assertion and Reason are false.

20. **Assertion :** A neutral body may experience a net non-zero magnetic force.

Reason : The net charge on a current carrying wire is zero, but it can experience a force in a magnetic field.

- Both assertion (A) and reason (R) are true and reason (R) is the correct explanation of assertion (A).
- Both assertion (A) and reason (R) are true but reason (R) is not the correct explanation of assertion (A).
- Assertion (A) is true but reason (R) is false.
- Assertion (A) is false but reason (R) is true.

Click the Following Button to See the Free MS/Solutions

SOLUTIONS

SECTION-B

Question no. 21 to 26 are very short answer questions.

21. What happens when a metal reacts with dilute acid?
or
How are the less reactive metals extracted ? Explain with the help of an example.
22. How are the lungs designated in human beings to maximise the area for exchange of gases ?
23. If both kidneys of a person stop functioning, which machine can be used ? What is this procedure known as ?
24. How do autotrophs obtain food ? Explain the process with the help of a balanced chemical equation.
25. What is meant by near point of a human eye ?

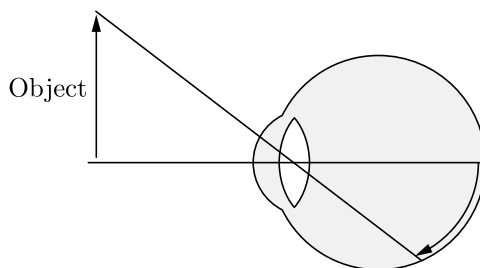

or

Write the role of the following parts of an eye :

- (a) Pupil,
 - (b) Retina,
 - (c) Optic nerve.
26. Government of India is imposing ban on the use of polythene bags for stopping. List for advantages of using cloth or jute bags over polythene bags.

SECTION-C

Question no. 27 to 33 are short answer questions.

27. In the electrolysis of water :
- (a) Name the gases liberated at anode and cathode.
 - (b) Why is it that the volume of gas collected on one electrode is two times that on the other electrode?
 - (c) What would happen if dil. H_2SO_4 is not added to water ?

Continue on next page.....

Click the Following Button to See the Free MS/Solutions

SOLUTIONS

28. (a) What is meant by reactivity series of metals ?
(b) Why metals are not equally reactive? Arrange the following metals in decreasing order of their reactivity: Fe, Ag, Na, Cu, Al.

29. What are the aspects included in reproductive health?

or

Write the two causes of human population explosion. Explain with the help of suitable examples how this explosion can be checked.

30. Rohit is uses a concave mirror which produces three times enlarged real image of an object placed at 12 cm in front of it. Calculate the radius of curvature of the mirror.

31. (a) Define 1 dioptre of power. Find the focal length of a lens of power -2.0 D.
(b) Why does a lemon kept in water in a glass tumbler appear to be bigger than its actual size?
(c) Study the table given below and state the medium in which light ray will travel fastest. Why ?

Medium	A	B	C
Refractive index	1.33	1.5	2.4

32. Explain two ways to induce current in a coil. When is the induced current produced highest ? State the rule used to find direction of induced current.

or

Write some precautions in the use of electricity.

33. You have been selected to talk on “ozone layer and its protection in the school assembly” on “Environment Day”
(i) Why should ozone layer be protected to save the environment ?
(ii) List any two ways that you would stress in your talk to bring in awareness amongst your fellow friends that would also help in protection of ozone layer as well as the environment.

SECTION-D

Question no. 34 to 36 are Long answer questions.

34. A compound X undergoes addition reaction with H_2 to form a compound Y having molecular mass 30 g mol^{-1} . X decolourize bromine water and burns with a smoky flame.
(a) Identify X and Y and write chemical equations of the reactions involved.
(b) Write the structural formulae of (i) Butanone and (ii) Pentanoic acid.
(c) Would you be able to check if water is hard by using a detergent ? Give reason to justify your answer.

or

- (a) Write the names and structures of (i) an alcohol, and (ii) an aldehyde with four carbon atoms in their molecules.
(b) List two differences between saturated and unsaturated hydrocarbons

Continue on next page.....

Click the Following Button to See the Free MS/Solutions

SOLUTIONS

35. Define the term pollination. Differentiate between self pollination and cross pollination. What is the significance of pollination?

or

- (a) Draw a longitudinal section of a flower and label the following parts :
- (i) Part that produces pollen grain.
 - (ii) Part that transfers male gametes to the female gametes.
 - (iii) Part that is sticky to trap the pollen grain.
 - (iv) Part that develops into a fruit.
- (b) Differentiate between pollination and fertilisation.

36. Although electric kettle and electric toaster were used simultaneously in the kitchen to prepare breakfast for the family, yet the two devices could work efficiently due to 'fuse' used in the electric circuit.



- (i) What is a fuse? Write the material used in fuse wires. How is a fuse connected in an electric circuit ?
- (ii) State the ratings of fuse used in electric circuits.
- (iii) What is the function of a fuse ? How does it perform its function ?
- (iv) A device uses 1 kW electric power when operated at 220 V. Calculate the rating of the fuse to be used.

Click the Following Button to See the Free MS/Solutions

SOLUTIONS

SECTION-E

Question no. 37 to 39 are case-based/data -based questions with 2 to 3 short sub-parts. Internal choice is provided in one of these sub-parts.

37.

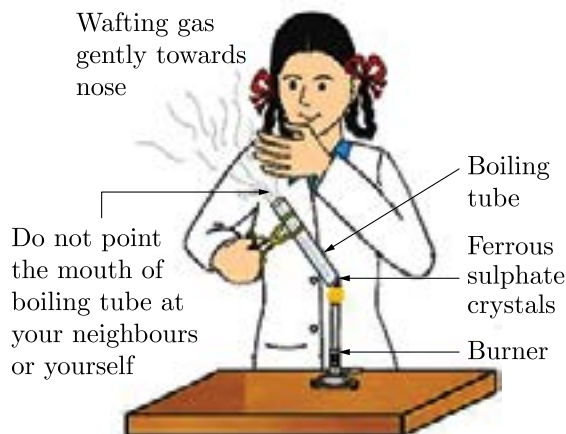

After seeing the above image answer the following questions.

- What was the colour of the crystals before heating and after heating?
- Write the chemical equation for the reaction.
- Which pungent smelling gas is evolved during the reaction ? What is the nature of this gas?

or

- Write the name of the solid substance formed.

38. The communication between the central nervous system and the other parts of the body is facilitated by the peripheral nervous system consisting of cranial nerves arising from the brain and spinal nerves arising from the spinal cord. The brain thus allows us to think and take actions based on that thinking. The brain has three such major parts or regions, namely the fore-brain, mid-brain and hind-brain. The fore-brain is the main thinking part of the brain. It has regions which receive sensory impulses from various receptors. Separate areas of the fore-brain are specialised for hearing, smell, sight and so on. There are separate areas of association where this sensory information is interpreted by putting it together with information from other receptors as well as with information that is already stored in the brain. Based on all this, a decision is made about how to respond and the information is passed on to the motor areas which control the movement of voluntary muscles.

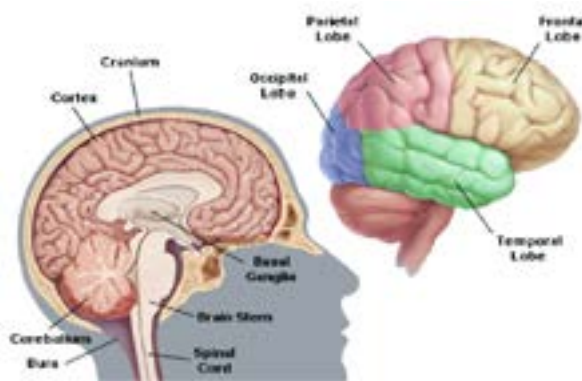

Continue on next page.....

Click the Following Button to See the Free MS/Solutions

SOLUTIONS

- (i) Which system facilitates the communication between the central nervous system and the other parts of the body ?
- (ii) What is the role of the brain ?
- (iii) What are three parts of the human brain ?
- or**
- (iv) Which is the main thinking part of the brain ?

39. Study the following table for a convex lens for different positions of object and answer the following questions:

Position of object	Position of image	Relative size of image
At infinity	At focus F_2	Highly diminished point sized
Beyond $2F_1$	Between F_2 and $2F_2$	Diminished
At $2F_1$	At $2F_2$	Same size
Between F_1 and $2F_1$	Beyond $2F_2$	Enlarged
At focus F_1	At infinity	Infinitely large or highly enlarged
Between focus F_1 and optical centre O	On the same side of the lens as the object	Enlarged

- (i) What is the nature of the image, if an object is placed at infinity ?
- (ii) Identify the nature of the image for which the object is between focus and optical centre.
- (iii) What is position of image, when object is placed at focus (f_1) ?
- or**
- (iv) What is the focal length of a lens for an object placed 50 cm from the lens producing virtual image at a distance of 10 cm in front of the lens?

□□□□□□

DOWNLOAD INDIA'S BEST STUDY MOBILE APP

- 30 Sample Paper with Solutions
- Chapterwise Question Bank of All Subject
- Previous 15 Years Solved Papers
- NCERT Solutions
- Case Study Questions with full Solutions
- **Word File of Material for Teachers**

Search by **NODIA** on Play Store to Download App

Add 89056 29969 in Your Class Whatsapp Group to Get Link

Click the Following Button to See the Free MS/Solutions

SOLUTIONS

Sample Paper 24

Class X 2023-24

Science (086)

Time: 3 Hours

Max. Marks: 80

General Instructions:

1. This question paper consists of 39 questions in 5 sections.
 2. All questions are compulsory. However, an internal choice is provided in some questions. A student is expected to attempt only one of these questions.
 3. Section A consists of 20 Objective Type questions carrying 1 mark each.
 4. Section B consists of 6 Very Short questions carrying 02 marks each. Answers to these questions should be in the range of 30 to 50 words.
 5. Section C consists of 7 Short Answer type questions carrying 03 marks each. Answers to these questions should be in the range of 50 to 80 words.
 6. Section D consists of 3 Long Answer type questions carrying 05 marks each. Answer to these questions should be in the range of 80 to 120 words.
 7. Section E consists of 3 source-based/case-based units of assessment of 04 marks each with sub-parts.
-

SECTION-A

Select and write one most appropriate option out of the four options given for each of the questions 1 – 20.

1.

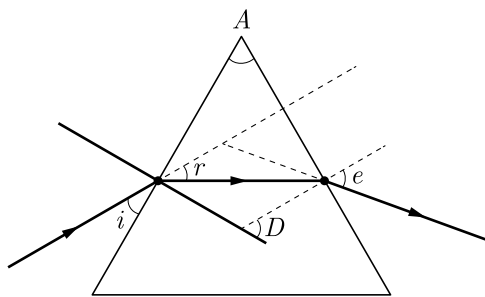

Which of the following angles are correctly marked in the above diagram?

- (a) $\angle A$, $\angle r$ and $\angle D$
 - (b) $\angle A$ and $\angle e$
 - (c) $\angle i$, $\angle A$ and $\angle D$
 - (d) $\angle A$, $\angle r$ and $\angle e$
2. Vinegar is a solution of
- (a) 50%-60% acetic acid in alcohol
 - (b) 5%-8% acetic acid in alcohol
 - (c) 5%-8% acetic acid in water
 - (d) 50%-60% acetic acid in water

Continue on next page.....

Click the Following Button to See the Free MS/Solutions

SOLUTIONS

3. In a flower, the parts that produce male and female gametes (germ cells) are
- (a) stamen and anther
 - (b) filament and stigma
 - (c) anther and ovary
 - (d) stamen and style

4. Which of the following are correctly matched?

1.	Common salt	formed by sodium hydroxide and hydrochloric acid.
2.	Brine	aqueous solution of sodium chloride.
3.	Chlor-alkali process	formation of sodium chloride

- (a) 1 and 2
 - (b) 2 and 3
 - (c) 1 and 3
 - (d) 1, 2 and 3
5. The bluish colour of water in deep sea is due to



- (a) the presence of algae and other plants found in water
 - (b) reflection of sky in water
 - (c) scattering of light
 - (d) absorption of light by the sea.
6. Which of the following is not a chemical change?
- (a) Burning of a candle.
 - (b) Cooking a food
 - (c) Sublimation
 - (d) Germination of seeds
7. What happens if a person has one kidney removed?
- (a) They will accumulate excess urea
 - (b) They will die
 - (c) They will continue as normal
 - (d) They will stop making urine

Continue on next page.....

Click the Following Button to See the Free MS/Solutions

SOLUTIONS

8. When the gases sulphur dioxide and hydrogen sulphide mix in the presence of water, the reaction is $\text{SO}_2 + 2\text{H}_2\text{S} \rightarrow 2\text{H}_2\text{O} + 3\text{S}$. Here hydrogen sulphide is acting as:
- (a) an oxidising agent
 - (b) a reducing agent
 - (c) a dehydrating agent
 - (d) a catalyst

9. Which of the following ray diagrams is correct for the ray of light incident on a concave mirror as shown in Figure?

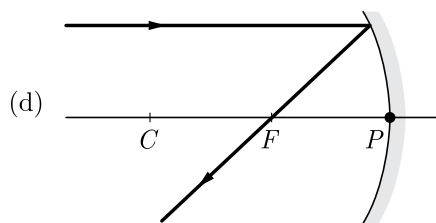
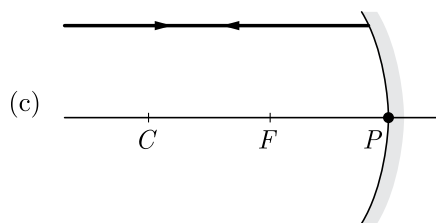
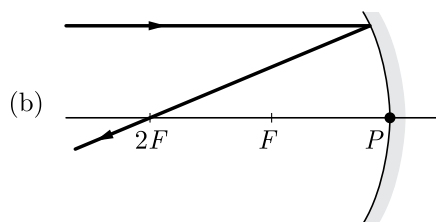
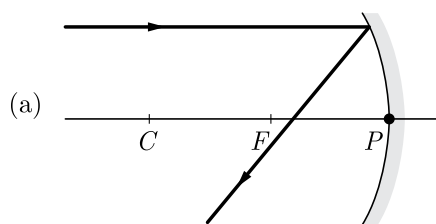
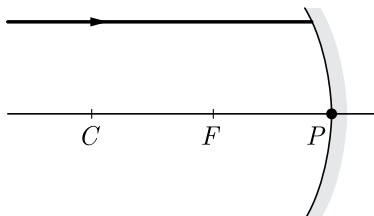

Continue on next page.....

Click the Following Button to See the Free MS/Solutions

SOLUTIONS

10. The function of valves present in auricles and ventricles is-
- It ensures that the blood flows only in one direction.
 - Helps in coagulation of blood
 - Destroy the worn out blood cells
 - Measure pressure of body fluids
11. The substance that triggers the fall of mature leaves and fruits from plants is due to
- auxins
 - gibberellin
 - abscisic acid
 - cytokinin
12. Barium chloride on reacting with ammonium sulphate forms barium sulphate and ammonium chloride. Which of the following correctly represents the type of the reaction involved?

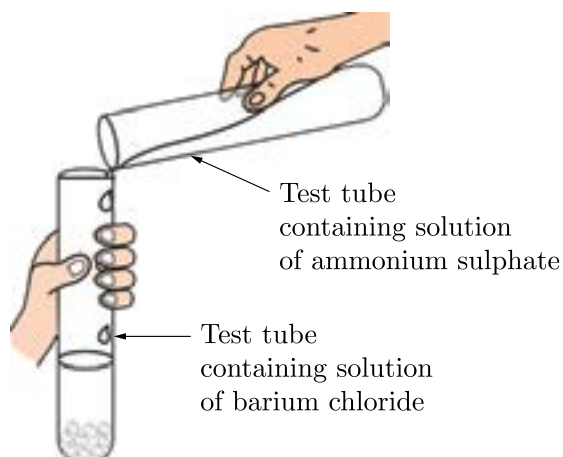

- Displacement reaction
 - Precipitation reaction
 - Combination reaction
 - Double displacement reaction
- Only 1
 - Only 2
 - Only 4
 - 2 and 4
13. An element *A* is soft and can be cut with a knife. This is very reactive to air and cannot be kept open in air. It reacts vigorously with water. Identify the element from the following :
- Mg
 - Na
 - P
 - Ca

Continue on next page.....

Click the Following Button to See the Free MS/Solutions

SOLUTIONS

14. Which of the following are correctly matched in the given table?

1.	Plants and animals	pH range is 7.0 to 7.8
2.	Rain water	pH is 7.6
3.	Tooth decay	pH less than 5.5

- (a) 1 and 2
 (b) 2 and 3
 (c) 1 and 3
 (d) 1, 2 and 3
15. A thin layer of water is transparent but a very thick layer of water is:
 (a) translucent
 (b) opaque
 (c) most transparent
 (d) none of these
16. Grasshopper in grassland is a



- (a) producer
 (b) herbivore
 (c) carnivore
 (d) none of the above

Question no. 17 to 20 are Assertion-Reasoning based questions.

17. **Assertion :** $\text{Fe}_2\text{O}_3 + 2\text{Al} \longrightarrow \text{Al}_2\text{O}_3 + 2\text{Fe}$

The above chemical equation is an example of displacement reaction.

Reason : Aluminium being more reactive than iron, displaces Fe from its oxide.

- (a) Both Assertion and Reason are True and Reason is the correct explanation of the Assertion.
 (b) Both Assertion and Reason are True but Reason is not the Correct explanation of the Assertion.
 (c) Assertion is True but the Reason is False.
 (d) Both Assertion and Reason are False.
18. **Assertion :** Nerve impulse is a one way conduction.
Reason : Nerve impulse is transmitted from dendrite to axon terminals.
 (a) Both assertion (A) and reason (R) are true and reason (R) is the correct explanation of assertion (A).
 (b) Both assertion (A) and reason (R) are true but reason (R) is not the correct explanation of assertion (A).
 (c) Assertion (A) is true but reason (R) is false.
 (d) Assertion (A) is false but reason (R) is true.

Continue on next page.....

Click the Following Button to See the Free MS/Solutions

SOLUTIONS

19. **Assertion :** The main organ of human excretory system is kidney.
Reason : Kidneys perform the function of adding water and nitrogenous wastes from the body.
- Both Assertion and Reason are true and Reason is the correct explanation of Assertion.
 - Both Assertion and Reason are true but Reason is not the correct explanation of Assertion.
 - Assertion is true but Reason is false.
 - Assertion is false but Reason is true.
20. **Assertion :** If ρ_1 and ρ_2 be the resistivity of the materials of two resistors of resistances R_1 and R_2 respectively and $R_1 > R_2$.
Reason : The resistance $R = \rho \frac{l}{A} \Rightarrow \rho_1 > \rho_2$ if $R_1 > R_2$
- Both assertion (A) and reason (R) are true and reason (R) is the correct explanation of assertion (A).
 - Both assertion (A) and reason (R) are true but reason (R) is not the correct explanation of assertion (A).
 - Assertion (A) is true but reason (R) is false.
 - Assertion (A) is false but reason (R) is true.

SECTION-B

Question no. 21 to 26 are very short answer questions.

21. An element reacts with air (oxygen) to form its oxide. When dissolved in water the solution turns red litmus blue. Is it a metal or a non-metal ? Justify your answer.

or

What properties do you think of while categorizing elements as metals and non-metals.

22. What is a receptor ? Name the receptors for light, sound and smell.
23. What is the effect of high temperature on the sex-determination in turtle (*Chrysema picta*) and the lizard (*Agama agama*)?
24. The organisms formed by asexual reproduction are considered as clones. Why? State the advantage of sexual reproduction over asexual reproduction.
25. An object is placed at a distance of 30 cm from a concave lens of focal lengths 15 cm. List four characteristics (nature, position, etc.) of the image formed by the lens.

or

An object is placed at a distance of 15 cm from concave lens of focal length 30 cm. List four characteristics (nature, position, etc.) of the image formed by the lens.

26. Write differences between food chain and food web.

Continue on next page.....

Click the Following Button to See the Free MS/Solutions

SOLUTIONS

SECTION-C

Question no. 27 to 33 are short answer questions.

27. Name the compound formed when ethanol is heated in excess of conc. sulphuric acid at 443 K. Also write the chemical equation of the reaction stating the role of conc. sulphuric acid in it. What would happen if hydrogen is added to the product of this reaction in the presence of catalysts such as palladium or nickel ?
28. Design an activity to show a decomposition reaction in which light is used to decompose a reactant. Write chemical equation for the reaction and state its one use.
29. Name the process of reproduction observed in yeast. Design an activity to observe this mode of reproduction in a school laboratory. Name one more organism which reproduces by this mode.

or

What is carpel? Write the function of its various parts.

30. What is dispersion of white light ? State its cause. Draw a ray diagram to show the dispersion of white light by a glass prism.
31. (a) State two main causes of developing far-sightedness.
(b) How can this defect of vision be corrected ?
32. For the circuit diagram given below, calculate :
(a) the value of current through each resistor.
(b) the total current in the circuit.
(c) the total effective resistance of the circuit.

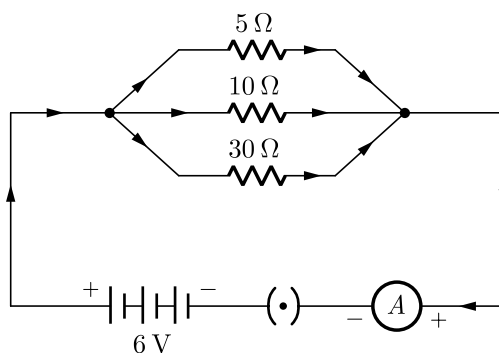

Continue on next page.....

Click the Following Button to See the Free MS/Solutions

SOLUTIONS

or

V - I graph for a conductor is as shown in figure.

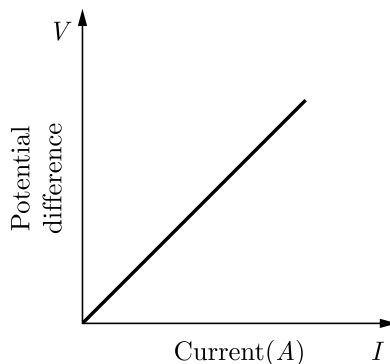

- (i) What do you infer from this graph ?
 - (ii) State the law expressed here
 - (iii) Name the physical quantity represented by the slope of this graph and its unit.
33. (a) How will an organism be benefited if it reproduces through spores ?
- (b) How is regeneration different from fragmentation?

SECTION-D

Question no. 34 to 36 are Long answer questions.

34. Write balanced chemical equation for the reactions taking place when :
- (i) Zinc carbonate is calcinated.
 - (ii) Zinc sulphide is roasted.
 - (iii) Zinc oxide is reduced to zinc.
 - (iv) Cinnabar is heated in the air.
 - (v) Manganese dioxide is heated with aluminium powder.

or

A metal M found in nature as sulphide ore (M_2S) is one of the good conductor of heat and electricity and used in making electric wires :

- (i) Identify the metal M.
 - (ii) Write the balanced chemical equations involved in the process of extraction of the metal.
 - (iii) Draw a labelled diagram of electrolytic refining of the metal.
35. State in brief the function of the following organs in the human female reproductive system :
- (a) Ovary
 - (b) Fallopian tube
 - (c) Uterus

or

- (i) What is vegetative propagation ?
- (ii) What methods you will use for growing jasmine and rose plants ?

Continue on next page.....

Click the Following Button to See the Free MS/Solutions

SOLUTIONS

36. (a) With the help of a suitable circuit diagram prove that the reciprocal of the equivalent resistance of a group of resistances joined in parallel is equal to the sum of the reciprocals of the individual resistances.
- (b) In an electric circuit two resistors of $12\ \Omega$ each are joined in parallel to a 6 V battery. Find the current drawn from the battery.

SECTION-E

Question no. 37 to 39 are case-based/data-based questions with 2 to 3 short sub-parts. Internal choice is provided in one of these sub-parts.

37. Study the table related to colour change with indicators and answer the questions that follow.

Solutions	Colour change with phenolphthalein indicator	Colour change with methyl orange indicator
<i>P</i>	Pink	Yellow
<i>Q</i>	Colourless	Orange
<i>R</i>	Colourless	Red

- (i) Name the solution which is acidic.
- (ii) Arrange the given solutions in increasing order of their pH value.
- (iii) What is the name of solution *P* and *Q* ?

or

- (iv) When solution *P* added to the china rose indicator, what is the colour of solution *P* ?

38. A scientist removed some cells from the growing point of a plant and placed it in a suitable medium leading to the formation of a shapeless lump of mass *X*. *X* is then transferred to another medium which stimulates it to develop roots. When *X* with developed roots is placed in a yet another medium, then it developed shoots to form tiny plantlets. These plantlets can then be transplanted in pots or soil where they can grow to form mature plants.

- (i) What is the shapeless lump of mass *X* known as?
- (ii) What name is given to this method of producing new plants?
- (iii) The growth medium used in this method contains plant nutrients in the form of a 'jelly' Name this jelly.

or

- (iv) What is the general name of chemicals used to stimulate the growth of plant cells and development of roots and shoots?

Continue on next page.....

Click the Following Button to See the Free MS/Solutions

SOLUTIONS

39. Three students Jahnvi, Snigdha and Aarati of class X brought three big plane mirrors in their class room for science fest . They fixed the three mirrors: one at the ceiling and the other two on the adjacent wall of the room. All three students was able to see more than three images of herself .Students of other classes also came to see this and felt happy.
- How many images of a single student were formed?
 - Give reason for number of images obtained in Q. no. (i).
 - Another student of class X takes a mirror which is depressed at the centre and mounts it on a mirror stand as shown in diagram. Now he focused the image of a candle flame on a white screen by placing the flame at various distances from the mirror.



He noted his observations as given below

Set	1	2	3	4	5	6
Distance of the flame from the mirror (cm)	20	25	30	40	60	75
Distance of the screen from the mirror (cm)	60	37.5	30	42	20	18.72

Name the mirror and find its focal length.

or

- One set of these observations in the above table is incorrect. Identify this set of observation and give reason for your choice.

□□□□□□

DOWNLOAD INDIA'S BEST STUDY MOBILE APP

- 30 Sample Paper with Solutions
- Chapterwise Question Bank of All Subject
- Previous 15 Years Solved Papers
- NCERT Solutions
- Case Study Questions with full Solutions
- **Word File of Material for Teachers**

Search by **NODIA** on Play Store to Download App

Add 89056 29969 in Your Class Whatsapp Group to Get Link

Click the Following Button to See the Free MS/Solutions

SOLUTIONS

Sample Paper 25

Class X 2023-24

Science (086)

Time: 3 Hours

Max. Marks: 80

General Instructions:

1. This question paper consists of 39 questions in 5 sections.
 2. All questions are compulsory. However, an internal choice is provided in some questions. A student is expected to attempt only one of these questions.
 3. Section A consists of 20 Objective Type questions carrying 1 mark each.
 4. Section B consists of 6 Very Short questions carrying 02 marks each. Answers to these questions should be in the range of 30 to 50 words.
 5. Section C consists of 7 Short Answer type questions carrying 03 marks each. Answers to these questions should be in the range of 50 to 80 words.
 6. Section D consists of 3 Long Answer type questions carrying 05 marks each. Answer to these questions should be in the range of 80 to 120 words.
 7. Section E consists of 3 source-based/case-based units of assessment of 04 marks each with sub-parts.
-

SECTION-A

Select and write one most appropriate option out of the four options given for each of the questions 1 – 20.

1. A metal rod (M) was dipped in a coloured solution (Y). After some time it was observed that the metal rod starts dissolving in the solution and the solution starts fading in colour. However, a coloured precipitate (Z) was seen at the bottom of the beaker. (M), (Y) and (Z) could be

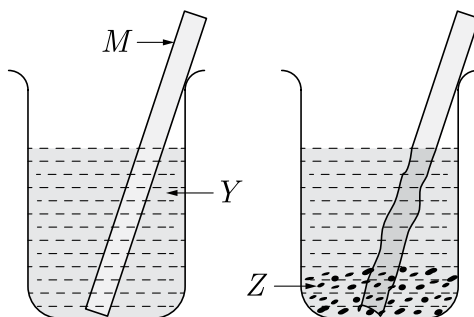

- (a) $M = \text{Zn}$ $Y = \text{FeSO}_4$ $Z = \text{Fe}$
(b) $M = \text{Cu}$ $Y = \text{Al}_2(\text{SO}_4)_3$ $Z = \text{Al}$
(c) $M = \text{Ag}$ $Y = \text{CuSO}_4$ $Z = \text{Cu}$
(d) $M = \text{Fe}$ $Y = \text{ZnSO}_4$ $Z = \text{Zn}$

Continue on next page.....

Click the Following Button to See the Free MS/Solutions

SOLUTIONS

2. The rate of breathing in aquatic organisms is much faster than that seen in terrestrial organisms, because-
- (a) the amount of dissolved oxygen in water is fairly high as compared to the amount of oxygen in the air.
 - (b) the amount of dissolved oxygen in water is fairly low as compared to the amount of oxygen in the air.
 - (c) aquatic organisms need more oxygen to breath.
 - (d) aquatic organisms do not have proper organs for breathing.
3. Two bulbs of 100 W and 40 W are connected in series. The current through the 100 W bulb is 1 A. The current through the 40 W bulb will be :

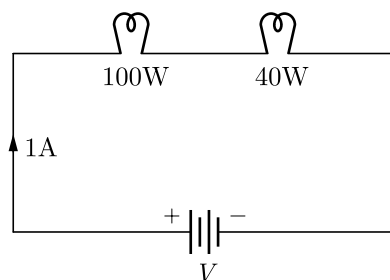

- (a) 0.4 A
 - (b) 0.6 A
 - (c) 0.8 A
 - (d) 1 A
4. The maleness of a child is determined by
- (a) the X chromosome in the zygote
 - (b) the Y chromosome in zygote
 - (c) the cytoplasm of germ cell which determines the sex
 - (d) sex is determined by chance
5. A student adds a few drops of the universal indicator to a dilute solution of sodium bicarbonate taken in a test tube.

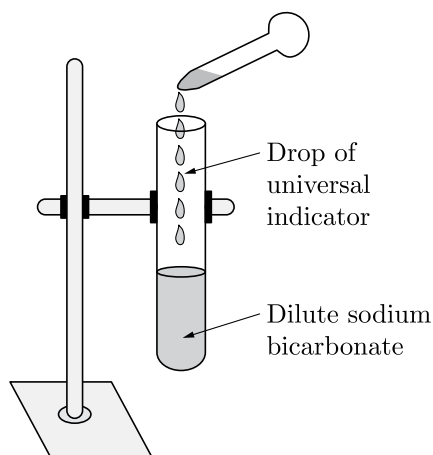

The colour of mixture of universal indicator and dilute sodium bicarbonate is:

- (a) Green
- (b) Yellow
- (c) Violet
- (d) Blue

Click the Following Button to See the Free MS/Solutions

SOLUTIONS

6. Which of the following are correctly matched in the given table?

1.	Combination reaction	Formation of single product.
2.	Decomposition reaction	Break down of single, entity.
3.	Thermal decomposition	Heat is used.
4.	Displacement reaction	Based on reactivity series.

- (a) 1, 2 and 3
 (b) 1, 2 and 4
 (c) 1, 3 and 4
 (d) 1, 2, 3 and 4

7. Which of the following is (are) true when HCl(g) is passed through water?

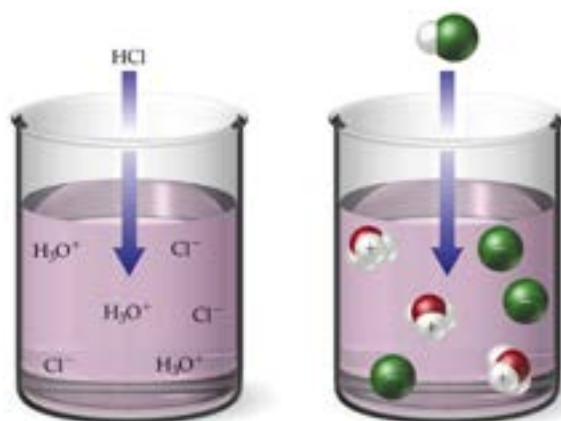

1. It does not ionise in the solution as it is a covalent compound.
 2. It ionizes in the solution.
 3. It gives both hydrogen and hydroxyl ion in the solution.
 4. It forms hydronium ion in the solution due to the combination of hydrogen ion with water molecule.
 (a) Only 1
 (b) Only 3
 (c) 2 and 4
 (d) 3 and 4

8. Which of the following represents saponification reaction ?

- (a) $\text{CH}_3\text{COONa} + \text{NaOH} \xrightarrow{\text{CaO}} \text{CH}_4 + \text{Na}_2\text{CO}_3$
 (b) $\text{CH}_3\text{COOH} + \text{C}_2\text{H}_5\text{OH} \xrightarrow{\text{H}_2\text{SO}_4} \text{CH}_3\text{COOC}_2\text{H}_5 + \text{H}_2\text{O}$
 (c) $2\text{CH}_3\text{COOH} + 2\text{Na} \longrightarrow 2\text{CH}_3\text{COONa} + \text{H}_2$
 (d) $\text{CH}_3\text{COOC}_2\text{H}_5 + \text{NaOH} \rightarrow \text{CH}_3\text{COONa} + \text{C}_2\text{H}_5\text{OH}$

9. Which metal have maximum reactivity?

- (a) K
 (b) Na
 (c) Au
 (d) Pt

Click the Following Button to See the Free MS/Solutions

SOLUTIONS

10. The process of movement of solvent particles from region of less solute concentration to region of high solute concentration through semi permeable membrane is known as
- (a) Diffusion
 - (b) Osmosis
 - (c) Transpiration
 - (d) Translocation
11. Light rays are deviated by a prism as shown in the figure.

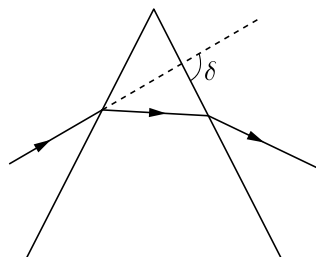

The deviation angle δ is measured for light rays of different frequency, including blue light and red light. Which of the following graph is correct?

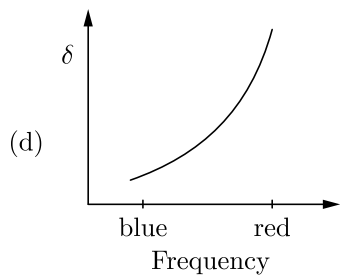
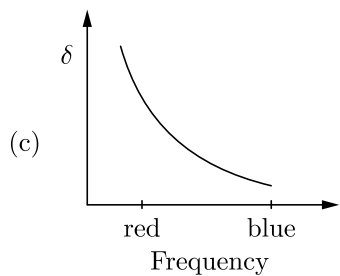
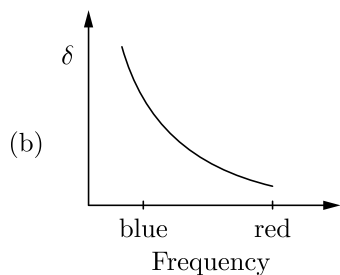
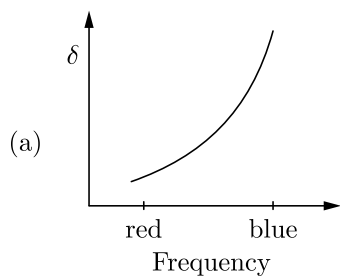

Click the Following Button to See the Free MS/Solutions

SOLUTIONS

12. Solid calcium oxide reacts vigorously with water to form calcium hydroxide accompanied by liberation of heat. This process is called slaking of lime. Calcium hydroxide dissolves in water to form its solution called lime water. Which among the following is (are) true about slaking of lime and the solution formed?

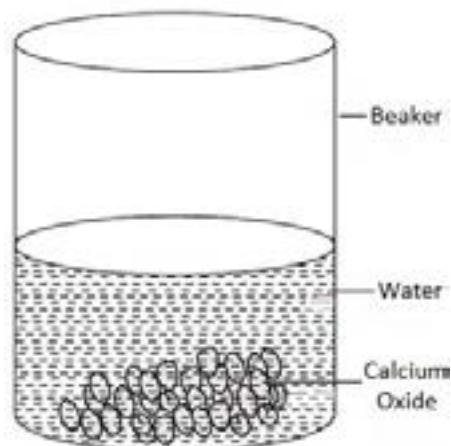

1. It is an endothermic reaction.
 2. It is an exothermic reaction.
 3. The pH of the resulting solution will be more than seven.
 4. The pH of the resulting solution will be less than seven.
- (a) 1 and 2
(b) 2 and 3
(c) 1 and 4
(d) 3 and 4
13. In a synapse, chemical signal is transmitted from
- (a) dendritic end of one neuron to axonal end of another neuron.
 - (b) axon to cell body the same neuron.
 - (c) cell body to axonal end of the same neuron.
 - (d) axonal end of one neuron to dendritic end of another neuron.
14. The correct sequence of reproductive stages seen in flowering plants is
- (a) gametes, zygote, embryo, seedling
 - (b) zygote, gametes, embryo, seedling
 - (c) seedling, embryo, zygote, gametes
 - (d) gametes, embryo, zygote, seedling
15. The maximum resistance which can be made using four resistors each of resistance $\frac{1}{2}\Omega$ is :
- (a) 2Ω
 - (b) 1Ω
 - (c) 2.5Ω
 - (d) 8Ω

Continue on next page.....

Click the Following Button to See the Free MS/Solutions

SOLUTIONS

16. Which of following source gives monochromatic light?
- (a) Sodium lamp
 - (b) Mercury lamp
 - (c) Spark lamp
 - (d) All of the above

Question no. 17 to 20 are Assertion-Reasoning based questions.

17. **Assertion :** Chips manufacturers usually flush bags of chips with oxygen gas.
Reason : It adds taste to chips.
- (a) Both Assertion and Reason are True and Reason is the correct explanation of the Assertion.
 - (b) Both Assertion and Reason are True but Reason is not the Correct explanation of the Assertion.
 - (c) Assertion is True but the Reason is False.
 - (d) Both Assertion and Reason are False.
18. **Assertion :** Plants lack the nervous system, but they do coordinate.
Reason : It is so because of hormones.
- (a) Both assertion (A) and reason (R) are true and reason (R) is the correct explanation of assertion (A).
 - (b) Both assertion (A) and reason (R) are true but reason (R) is not the correct explanation of assertion (A).
 - (c) Assertion (A) is true but reason (R) is false.
 - (d) Assertion (A) is false but reason (R) is true.
19. **Assertion :** in the daytime, CO_2 generated during respiration is used up for photosynthesis.
Reason : There is no CO_2 release during day.
- (a) Both Assertion and Reason are true and Reason is the correct explanation of Assertion.
 - (b) Both Assertion and Reason are true but Reason is not the correct explanation of Assertion.
 - (c) Assertion is true but Reason is false.
 - (d) Assertion is false but Reason is true.
20. **Assertion :** A small coil carrying current, in equilibrium, is perpendicular to the direction of the uniform magnetic field.
Reason : Torque is maximum when plane of coil and direction of the magnetic field are parallel to each other.
- (a) Both assertion (A) and reason (R) are true and reason (R) is the correct explanation of assertion (A).
 - (b) Both assertion (A) and reason (R) are true but reason (R) is not the correct explanation of assertion (A).
 - (c) Assertion (A) is true but reason (R) is false.
 - (d) Assertion (A) is false but reason (R) is true.

SECTION-B

Question no. 21 to 26 are very short answer questions.

21. Out of the two—hydrochloric acid and acetic acid, which one is considered a strong acid and why ? Write the name/ molecular formula of one more strong acid.

or

Name the acid produced in our stomach. What happens if there is an excess of acid in the stomach? How can it be cured ? Name the antacid.

Continue on next page.....

Click the Following Button to See the Free MS/Solutions

SOLUTIONS

22. A graph was plotted to show the energy output of two types of respiration. Identify the type of respiration denoted by curves *A* and *B*.

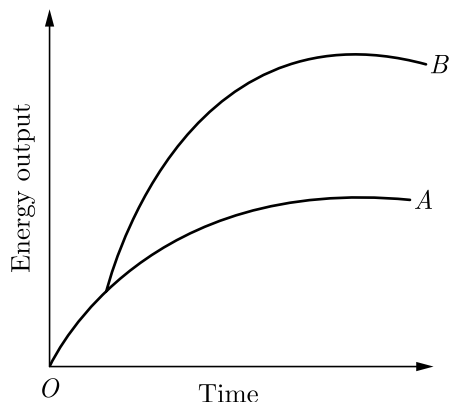

23. Why are the chances of variation more in sexually developing organisms ?
24. You soak seeds of bean and observe them after 2-3 days. What will be your observations?
25. Calculate the equivalent resistance from the following combination of resistors.

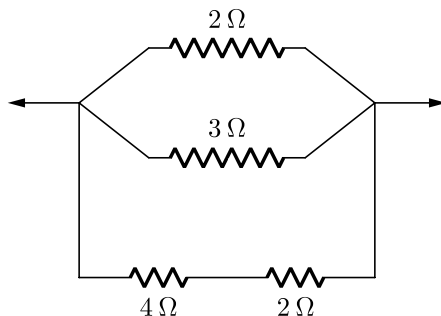

or

What would be the readings of ammeter and voltmeter in the given circuit ?

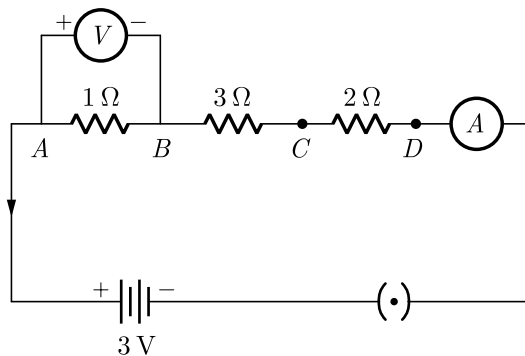

26. Name the sources from where the green plants obtain C, H and O.

Click the Following Button to See the Free MS/Solutions

SOLUTIONS

SECTION-C

Question no. 27 to 33 are short answer questions.

27. Write an experiment to show that copper does not react with dilute HCl.

28. What is a thermochemical equation ? Give two examples.

29. How do Mendel's experiments show that traits may be dominant or recessive?

or

With the help of two suitable examples explain why certain experiences and traits earned by people during their lifetime are not passed onto their next generations. When such traits be passed on?

30. (a) Ravi kept a book at a distance of 10 cm from the eyes of his friend Hari. Hari is not able to read anything written on the book. Explain why ?
 (b) A lens of focal length 5.0 cm is being used by a student in the laboratory as a magnifying glass. His least distance of distinct vision is 25 cm. What magnification is the student getting ?

31.

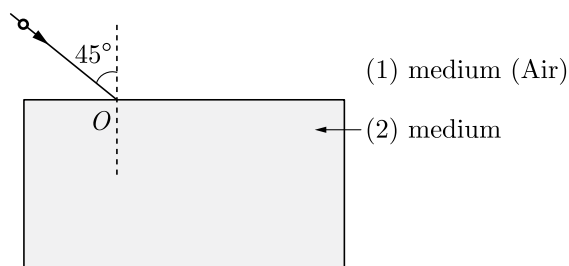

- (a) A ray of light is incident at an angle of 45° at the interface of medium (1) and medium (2) as shown in the above diagram. Redraw this diagram in the answer book and complete it. If the angle of refraction is 30° find the refractive index of medium (2) with respect to medium (1).
 (Given that $\sin 45^\circ = \frac{1}{\sqrt{2}}$ and $\sin 30^\circ = \frac{1}{2}$)
- (b) If second medium is water in place of medium (2), will the angle of refraction increase or decrease ? Why ?
 (Refractive index of water = $\frac{4}{3}$)
32. State Joules law of heating. List two special characteristics of a heating element wire.
 An electric iron consumes energy at the rate of 880W when heating is at the maximum rate and 440W when the heating is at the minimum rate. The applied voltage is 220 V. Calculate the current and resistance in each case.

or

Study the given electric circuit and calculate :

- (i) the current flowing through the $4\ \Omega$ resistor and
 (ii) potential difference across the combination of two resistor of $8\ \Omega$ each.

Continue on next page.....

Click the Following Button to See the Free MS/Solutions

SOLUTIONS

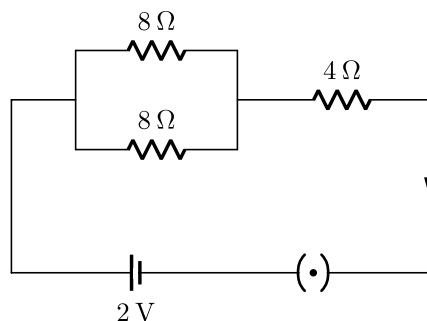

33. (a) “Improvements in our lifestyle have resulted in greater amounts of waste generation.” Give two examples to support the given statement. Suggest one change that we can incorporate in our lifestyle in order to reduce non-biodegradable waste.
- (b) The following organisms form a food chain.
Insect, Hawk, Grass, Snake, Frog
- Which of these will have highest concentration of non-biodegradable chemicals? Name the phenomenon.

SECTION-D

Question no. 34 to 36 are Long answer questions.

34. A student dropped few pieces of marble in dilute hydrochloric acid, contained in a test tube. The evolved gas was then passed through lime water. What change would be observed in lime water ? What will happen if excess of gas is passed through lime water ? Write balanced chemical equations for all the changes observed.

or

- (i) What are strong acids and weak acids? Give an example for each.
- (ii) A dry pellet of a common base B when kept in open absorbs moisture and turns sticky. The compound is also formed by chlor-alkali process. Identify B . What type of reaction occurs when B is treated with dilute hydrochloric acid ? Write the chemical equation.
35. Give reasons :
- (a) Ventricles have thicker muscular walls than atria.
- (b) Transport system in plants is slow.
- (c) Circulation of blood in aquatic vertebrates differs from that in terrestrial vertebrates.
- (d) During the daytime, water and minerals travel faster through xylem as compared to the night.
- (e) Veins have valves whereas arteries do not.

or

How would you classify a green plant, an animal, a fungus and a roundworm based on their modes of nutrition ? Explain very briefly the manner how they get their nutrition.

36. (i) With the help of an activity, explain the method of inducing electric current in a coil with a moving magnet. State the rule used to find the direction of electric current thus generated in the coil.
- (ii) Two circular coils-1 and coil-2 are kept close to each other as shown in the diagram. Coil-1 is connected to a battery and key and coil-2 with a galvanometer. State your observation in the galvanometer:

Continue on next page.....

Click the Following Button to See the Free MS/Solutions

SOLUTIONS

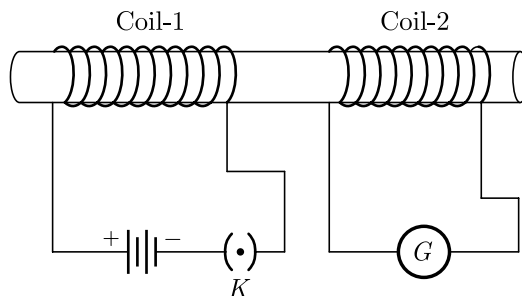

- (a) When key K closed;
 (b) When key K is opened;
 Give reason for your observations.

SECTION-E

Question no. 37 to 39 are case-based/data-based questions with 2 to 3 short sub-parts. Internal choice is provided in one of these sub-parts.

37. A student prepared oxygen in a lab by catalytic decomposition of potassium chlorate (KClO_3) as shown in the figure. Decomposition of potassium chlorate gives potassium chloride (KCl) and oxygen (O_2). The following reaction takes place :

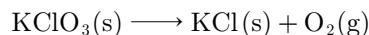

- (i) How many moles of KClO_3 are required to produce 2.4 moles of O_2 ?
 (ii) Name the element which is reduced in the given reaction.
 (iii) How many moles of KClO_3 give 3 moles of oxygen?

or

- (iv) What is the oxidation state of chlorine in potassium chlorate?

38. The sexual act always has the potential to lead to pregnancy will make major demands on the body and the mind of the woman and if she is not ready for it, her health will be adversely affected. Therefore, many ways have been devised to avoid pregnancy.



- (i) Name any two bacterial diseases that are caused due to unprotected sex.
 (ii) In what a pill helps in preventing pregnancy?
 (iii) What is vasectomy?

or

- (iv) What are the common side-effects of using contraceptive pills?

Click the Following Button to See the Free MS/Solutions

SOLUTIONS

39. The ciliary muscle muscles of eye control the curvature of the lens in the eye and hence can alter the effective focal length of the system. When the muscles are fully relaxed, the focal length is maximum. When the muscles are strained the curvature of lens increases (that means radius of curvature decreases) and focal length decreases. For a clear vision the image must be on retina. The image distance is therefore fixed for clear vision and it equals the distance of retina from eye-lens. It is about 2.5 cm for a grown-up person.

A person can theoretically have clear vision of objects situated at any large distance from the eye. The smallest distance at which a person can clearly see is related to minimum possible focal length, The ciliary muscles are most strained in this position. For an average grown-up person minimum distance of object should be around 25 cm.

A person suffering for eye defects uses spectacles (Eye glass). The function of lens of spectacles is to form the image of the objects within the range in which person can see clearly. The image of the spectacle-lens becomes object for eye-lens and whose image is formed on retina.

The number of spectacle-lens used for the remedy of eye defect is decided by the power of the lens required and the number of spectacle-lens is equal to the numerical value of the power of lens with sign. For example power of lens required is +3D (converging lens of focal length 100/3 cm) then number of lens will be +3.

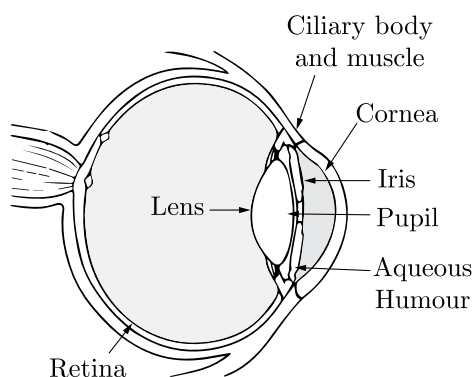

For all the calculations required you can use the lens formula and lens maker's formula. Assume that the eye lens is equiconvex lens. Neglect the distance between eye lens and the spectacle lens.

- (i) What do you mean by the ciliary muscles ?
- (ii) What is the minimum focal length of eye lens of a normal person ?
- (iii) What is the maximum focal length of eye lens of normal person ?

or

- (iv) A near-sighted man can clearly see object only up-to a distance of 100 cm and not beyond this. What is the number of the spectacles lens necessary for the remedy of this defect ?

□□□□□□

DOWNLOAD INDIA'S BEST STUDY MOBILE APP

- 30 Sample Paper with Solutions
- Chapterwise Question Bank of All Subject
- Previous 15 Years Solved Papers
- NCERT Solutions
- Case Study Questions with full Solutions
- **Word File of Material for Teachers**

Search by **NODIA** on Play Store to Download App

Add 89056 29969 in Your Class Whatsapp Group to Get Link

Click the Following Button to See the Free MS/Solutions

SOLUTIONS

Sample Paper 26

Class X 2023-24

Science (086)

Time: 3 Hours

Max. Marks: 80

General Instructions:

1. This question paper consists of 39 questions in 5 sections.
 2. All questions are compulsory. However, an internal choice is provided in some questions. A student is expected to attempt only one of these questions.
 3. Section A consists of 20 Objective Type questions carrying 1 mark each.
 4. Section B consists of 6 Very Short questions carrying 02 marks each. Answers to these questions should be in the range of 30 to 50 words.
 5. Section C consists of 7 Short Answer type questions carrying 03 marks each. Answers to these questions should be in the range of 50 to 80 words.
 6. Section D consists of 3 Long Answer type questions carrying 05 marks each. Answer to these questions should be in the range of 80 to 120 words.
 7. Section E consists of 3 source-based/case-based units of assessment of 04 marks each with sub-parts.
-

SECTION-A

Select and write one most appropriate option out of the four options given for each of the questions 1 – 20.

1. A student plots V-I graphs for three samples of nichrome wire with resistances R_1 , R_2 and R_3 . Choose from the following statement that holds true for this graph:

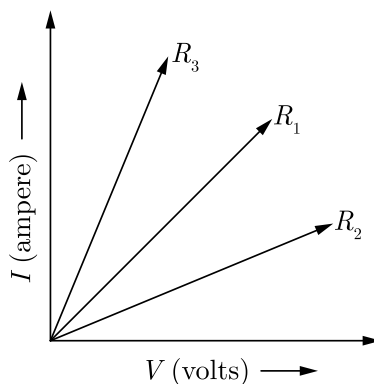

- (a) $R_1 > R_2 > R_3$
- (b) $R_1 = R_2 = R_3$
- (c) $R_2 > R_1 > R_3$
- (d) $R_3 > R_2 > R_1$

Continue on next page.....

Click the Following Button to See the Free MS/Solutions

SOLUTIONS

2.

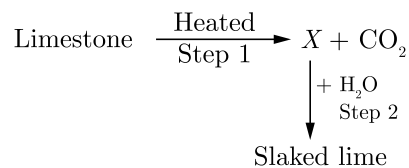

Identify the correct option from the given table which represents the type of reactions occurring in step 1 and step 2.

Option	Endothermic	Exothermic
a.	✗	✓
b.	✓	✗
c.	✓	✓
d.	✗	✗

3. The resistance of a resistor is reduced to half of its initial value. In doing so, if other parameters of the circuit remain unchanged, the heating effects in the resistor will become:
- (a) half
 - (b) two times
 - (c) four times
 - (d) one-fourth
4. The image shows the reproductive organ in females.

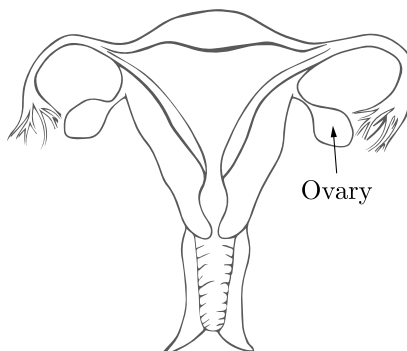

Which event will likely occur in the ovaries of females after attaining puberty?

- (a) Synthesis of eggs
- (b) Fertilisation
- (c) Growth and development of embryo
- (d) Production of eggs

Continue on next page.....

Click the Following Button to See the Free MS/Solutions

SOLUTIONS

5. The given figures show movement seen in *Mimosa pudica* plant when it is touched.



Select the incorrect option regarding this.

- (a) The movement is non-directional that occurs due to turgor changes.
 (b) The movement is directional that involves growth.
 (c) The movement is in response to touch and is called thigmonasty.
 (d) The movement is immediate in response to stimulus.
6. When a fuse is rated at 8 A, it means:
 (a) it will burn if current exceeds 8 A
 (b) it will work only if current is 8 A
 (c) it has a resistance of 8Ω
 (d) it will not work if current is less than 8 A

7. Identify X, Y and Z respectively in the given reaction

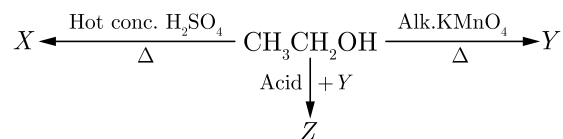

- (a) $\text{CH}_2 = \text{CH}_2$, CH_3COOH , $\text{CH}_3\text{COOCH}_2\text{CH}_3$
 (b) CH_3COOH , $\text{CH}_2 = \text{CH}_2$, $\text{CH}_3\text{COOCH}_3$
 (c) CH_3CH_3 , HCHO , CH_3COOH
 (d) HCHO , CH_3CH_3 , $\text{CH}_3\text{CH}_2\text{COOH}$
8. How will you protect yourself from the heat generated while diluting a concentrated acid?
 (a) By adding water to acid with constant stirring
 (b) By adding acid to water with constant stirring
 (c) By adding base to acid with constant stirring
 (d) By adding water to acid followed by base
9. It is important to balance the chemical equations to satisfy the law of conservation of mass. Which of the following statements of the law is incorrect?
 (a) The number of atoms of each elements remains the same, before and after a chemical reaction.
 (b) The total mass of the elements present in the reactants is equal to the total mass of the elements presents in the products.
 (c) Mass can neither be created nor can it be destroyed in a chemical reaction.
 (d) The chemical composition of the reactants is the same before and after the reaction.

Continue on next page.....

Click the Following Button to See the Free MS/Solutions

SOLUTIONS

10. 50.0 mL of tap water was taken in a beaker. Hydrochloric acid was added drop by drop to water. The temperature and pH of the solution was noted. The following graph was obtained. Choose the correct statements related to this activity.

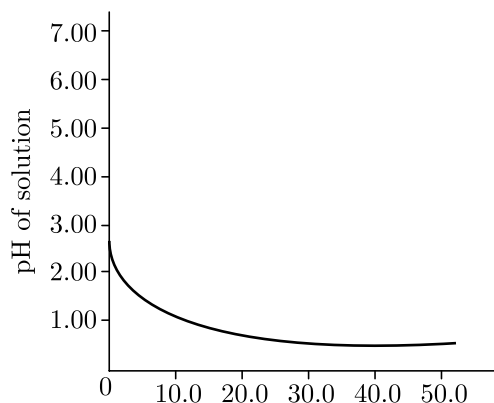

Volume of HCl added (ml).

- (i) The process of dissolving an acid in water is highly endothermic.
 - (ii) The pH of the solution increases rapidly on addition of acid.
 - (iii) The pH of the solution decreases rapidly on addition of acid.
 - (iv) The pH of tap water was around 7.0
- (a) (i) and (iii)
 - (b) (i) and (ii)
 - (c) (ii) and (iv)
 - (d) (iii) and (iv)
11. Observe the image of a single nephron.

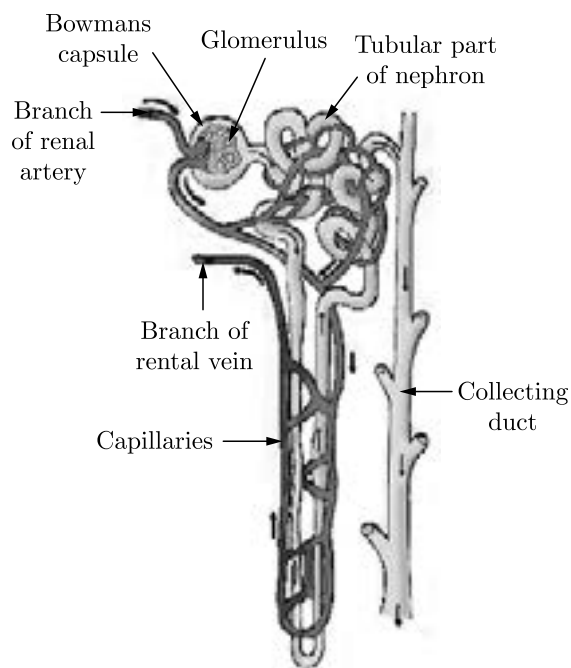

Continue on next page.....

Click the Following Button to See the Free MS/Solutions

SOLUTIONS

The amount of liquid passing through in the form of glomerular filtrate is approximately 150-180 litres per day whereas the amount of urine flowing out of all the nephrons is only 1.5 to 1.8 litres per day.

Water is getting reabsorbed.

In which part of the nephron could the water be getting reabsorbed?

- (a) In the long tubular part
 (b) In the Bowman's cup
 (c) In the glomerulus
 (d) In the collecting duct
12. If the key in the arrangement is taken out (the circuit is made open) and magnetic field lines are drawn over the horizontal plane ABCD, the lines are:

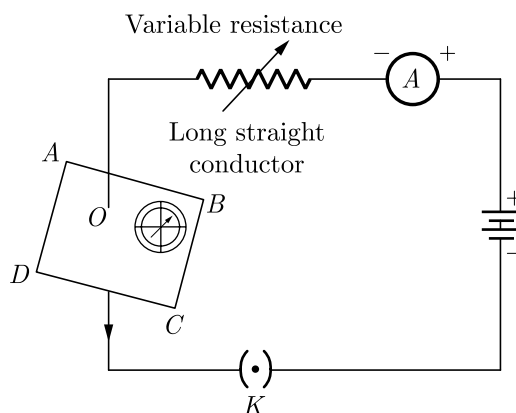

- (a) elliptical in shape
 (b) concentric circles
 (c) concentric circles near the point O but of elliptical shapes as we go away from it
 (d) straight lines parallel to each other
13. The two versions of a trait (character) which are brought in by the male and female gametes are situated on:
- (a) two different chromosomes
 (b) copies of the same chromosome
 (c) any chromosome
 (d) sex chromosomes
14. Which one of the following structures correctly depicts the compound CaCl_2 ?

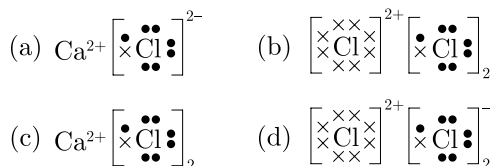

Continue on next page.....

Click the Following Button to See the Free MS/Solutions

SOLUTIONS

15. Carefully study the diagram of the human respiratory system with labels (i), (ii), (iii) and (iv). Select the option which gives correct identification and main function and/or characteristic.

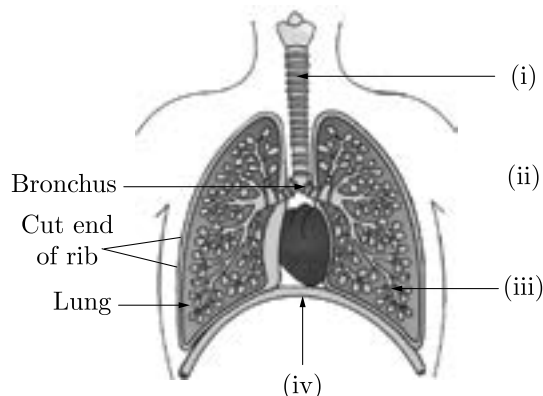

- (a) (i) Trachea: It is supported by bony rings for conducting inspired air.
 (b) (ii) Ribs: When we breathe out, ribs are lifted.
 (c) (iii) Alveoli: Thin-walled sac like structures for exchange of gases.
 (d) (iv) Diaphragm: It is pulled up when we breathe in.
16. The primary function of trachea is to provide air passage to the lungs for respiration. When we breathe in, ribs are lifted and diaphragm is flattened. Observe the given diagram and identify the correct statements.

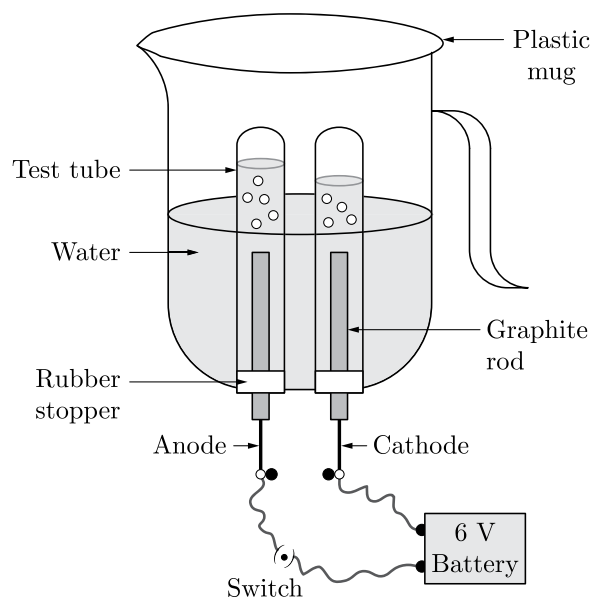

- (i) At anode, oxygen gas is evolved.
 (ii) In the test tube covering the anode, the amount of gas collected is double than that of the gas collected in the test tube covering the cathode.
 (iii) At cathode, hydrogen gas is evolved.
 (iv) It is a decomposition reaction.
 (a) (i), (iii) and (iv)
 (b) (i), (ii) and (iii)
 (c) All the statements are correct.
 (d) (iii) and (iv)

Click the Following Button to See the Free MS/Solutions

SOLUTIONS

Question no. 17 to 20 are Assertion-Reasoning based questions.

17. **Assertion (A):** In many reptiles, sex determination rely entirely on environmental factors.
Reason (R): The temperature at which fertilised eggs are kept determines whether the animal developing in the eggs will be a male or female.
- Both Assertion (A) and Reason (R) are true and Reason (R) is the correct explanation of Assertion (A).
 - Both Assertion (A) and Reason (R) are true but Reason (R) is not the correct explanation of Assertion (A).
 - Assertion (A) is true but Reason (R) is false.
 - Assertion (A) is false but Reason (R) is true.
18. **Assertion (A):** A compass needle is placed near a current carrying wire. The deflection of the compass needle decreases when the magnitude of electric current in the wire increases.
Reason (R): The magnitude of the magnetic field produced at a point increases as the current through the wire increases.
- Both Assertion (A) and Reason (R) are true and Reason (R) is the correct explanation of Assertion (A).
 - Both Assertion (A) and Reason (R) are true but Reason (R) is not the correct explanation of Assertion (A).
 - Assertion (A) is true but Reason (R) is false.
 - Assertion (A) is false but Reason (R) is true.
19. **Assertion (A):** Hydrochloric acid helps in the digestion of food in the stomach.
Reason (R): Hydrochloric acid creates an acidic medium to activate protein digesting enzymes.
- Both Assertion (A) and Reason (R) are true and Reason (R) is the correct explanation of Assertion (A).
 - Both Assertion (A) and Reason (R) are true but Reason (R) is not the correct explanation of Assertion (A).
 - Assertion (A) is true but Reason (R) is false.
 - Assertion (A) is false but Reason (R) is true.
20. **Assertion (A):** $2\text{H}_2\text{S}(\text{g}) + \text{O}_2(\text{g}) \longrightarrow 2\text{S}(\text{s}) + 2\text{H}_2\text{O}(\text{l})$ is a redox reaction.
Reason (R): In this reaction, oxidation of H_2S to S and reduction of O_2 to H_2O takes place.
- Both Assertion (A) and Reason (R) are true and Reason (R) is the correct explanation of Assertion (A).
 - Both Assertion (A) and Reason (R) are true but Reason (R) is not the correct explanation of Assertion (A).
 - Assertion (A) is true but Reason (R) is false.
 - Assertion (A) is false but Reason (R) is true.

SECTION-B

Question no. 21 to 26 are very short answer questions.

21. What is a rainbow? Draw a labelled diagram to show the formation of a rainbow.

or

A beam of white light falling on a glass prism gets split up into seven colours marked 1 to 7 as shown in the diagram.

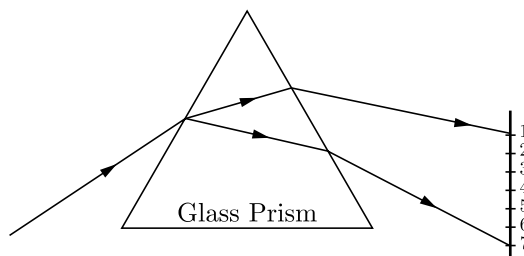

Continue on next page.....

Click the Following Button to See the Free MS/Solutions

SOLUTIONS

Which two positions correspond closely to the colour of

- (i) a solution of potassium permanganate
 - (ii) danger or stop signal lights?
22. What is haemoglobin? State the consequences of deficiency of haemoglobin in our bodies.
23. What is the difference between the organisms belonging to the first and the third trophic levels? Give one example each of the organisms belonging to these two trophic levels.
24. Differentiate between an autotroph and a heterotroph.
25. Write the balanced chemical equations for the following reactions and identify the type of reaction in each case.
- (i) Nitrogen gas is treated with hydrogen gas in the presence of a catalyst at 773K to form ammonia gas.
 - (ii) Ethene is burnt in the presence of oxygen to form carbon dioxide, water and releases heat and light.
- or**
- Blue litmus solution is added to two test tubes A and B containing dilute HCl and NaOH solution respectively. In which test tube a colour change will be observed? State the colour change and give its reason.
26. Trace the sequence of events which occur when a bright light is focused on your eyes.

SECTION-C

Question no. 27 to 33 are short answer questions.

27. The nature, size and position of image of an object produced by a lens or mirror are as shown below. Identify the lens/mirror (X) used in each case and draw the corresponding complete ray diagram, (size of the object about half of the image).

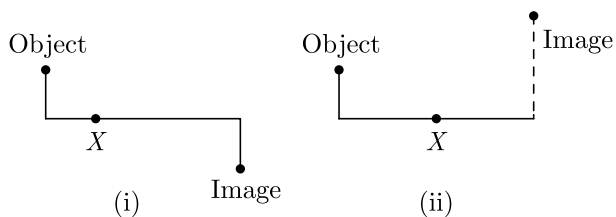

28. (i) State Snell's law of refraction of light.
(ii) When a ray of light travelling in air enters obliquely into a glass slab, it is observed that the, Light ray emerges parallel to the incident ray but it is shifted sideways slightly. Draw a labelled ray diagram to illustrate it.
29. (i) Draw the pattern of magnetic field lines due to a magnetic field through and around a current carrying circular loop.
(ii) Name and state the rule to find out the direction of magnetic field inside and around the loop.

or

What is a solenoid? Draw the pattern of magnetic field lines of

- (i) a current carrying solenoid and a bar magnet.
- (ii) List two distinguishing features between the two fields.

Continue on next page.....

Click the Following Button to See the Free MS/Solutions

SOLUTIONS

30. You are given a white solid which is calcium carbonate, CaCO_3 .

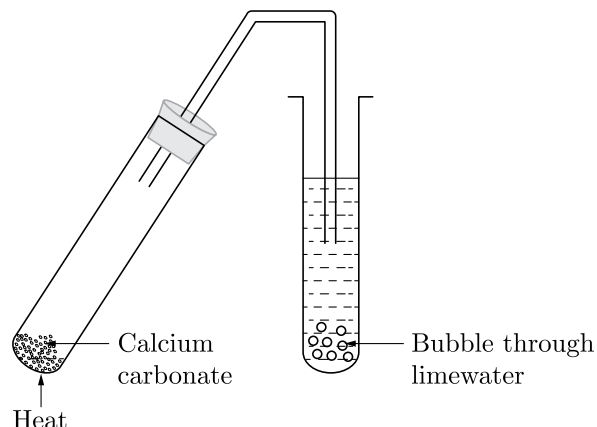

- (i) What happens to the white solid after heating?
 - (ii) What will you observe in the lime water during the heating process?
 - (iii) Write the reactions involved.
31. The graph shows how the pH of the soil in a farmer's field changed over a period of time

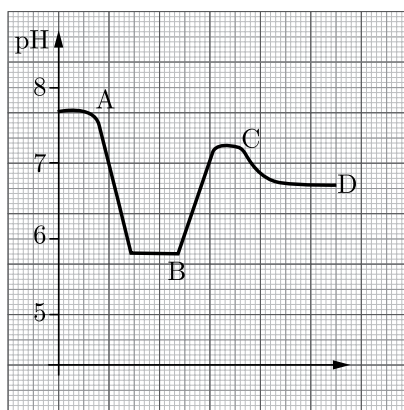

- (i) At which point A, B, C or D did the farmer apply lime to the field.
 - (ii) What is the importance of pH in our daily life?
 - (iii) Give two examples showing importance of neutralisation in our daily life.
32. (i) State the role played by the following in the process of digestion:
- (a) Enzyme trypsin
 - (b) Enzyme lipase
- (ii) List two functions of finger like projection present in the small intestine.
- or**
- (i) Write the correct sequence of steps followed during journey of oxygen rich blood from lungs to various organs of human body.
 - (ii) What happens when the system of blood vessels develop a leak?

Continue on next page.....

Click the Following Button to See the Free MS/Solutions

SOLUTIONS

33. How can we help in reducing the problem of waste disposal? Suggest any three methods.

SECTION-D

Question no. 34 to 36 are Long answer questions.

34. Differentiate between the following:

- (i) Pollen tube and style
- (ii) fission in Amoeba and Plasmodium
- (iii) Fragmentation and regeneration
- (iv) Bud of Hydra and bud of Bryophyllum
- (v) Vegetative propagation and spore formation

or

- (i) What is puberty?
- (ii) Describe in brief the functions of the following parts in the human male reproductive system:
 - (a) Testes
 - (b) Seminal vesicle
 - (c) Vas deferens
 - (d) Urethra
- (iii) Why are testes located outside the abdominal cavity?
- (iv) State how sperms move towards the female germ cell.

35. With the help of a diagram of experimental setup, describe an activity to show that the force acting on a current carrying conductor placed in a magnetic field increases with increase in field strength.

36. The compounds methanal, ethanal, propanal and butanal belong to the homologous series called aldehydes. The table shows some information on these four aldehydes.

Name	Formula	Boiling Point/ $^{\circ}\text{C}$	Solubility in water
Methanal	HCHO	-21	very soluble
Ethanal	CH_3CHO	21	very soluble
Propanal	$\text{CH}_3\text{CH}_2\text{CHO}$	49	soluble
Butanal	$\text{CH}_3\text{CH}_2\text{CH}_2\text{CHO}$	76	slightly soluble

- (i) List two characteristics of this homologous series using the information shown in the table.
- (ii) Compare the molecular formulae of the four aldehydes listed in the table. What conclusion can you make?
- (iii) Draw the electronic structure of ethanal. You need to show only the outer shell electrons.

or

- (i) Compare soaps and detergents on the basis of their composition and cleansing action in hard water.
- (ii) What happens when ethanol is treated with sodium metal? State the behaviour of ethanol in this reaction.
- (iii) Draw the structure of cyclohexane.
- (iv) Name the following compound

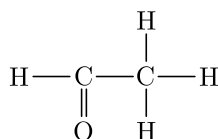

Click the Following Button to See the Free MS/Solutions

SOLUTIONS

SECTION-E

Question no. 37 to 39 are case-based/data-based questions with 2 to 3 short sub-parts. Internal choice is provided in one of these sub-parts.

37. Manoj wanted to fix the rear-view mirror of his bike. He knows that rear-view mirror is an essential safety device in the vehicle and allows him to see objects at the backside of his vehicle.



He bought two mirrors M_1 and M_2 , out of which M_1 is curved inwards and M_2 is curved outwards.

- (i) Based on the given situation, which mirror should Manoj need to fix as his rear-view mirror and why?
- (ii) An object is placed at the centre of curvature of M_1 . Find the distance between its image and pole.
- (iii) Manoj did some preliminary experiment with mirror M_1 and found that magnification of the real image of an object placed at 10 cm in front of it is 3, at what distance is the image located?

or

- (iv) An object is placed 60 cm in front of M_2 . The image formed by the mirror is located 30 cm behind the mirror. What is the object's magnification?

38. When a silvery grey powder of a solid (A) is mixed with a powder of solid (B) no reaction occurs. But if the mixture is ignited and lighted using magnesium ribbon a reaction occurs with evolution of large amount of heat forming product (C) which settles down as liquid metal and the solid product (D) formed floats on the liquid (C) in solid form reacts with moisture to form rust.

The amount of heat generated during the reaction is so high that the reaction is used in welding of electric conductors, joints in railway tracks.

- (i) Identify (A), (B), (C) and (D). Write the balanced chemical equation for the reaction. Name the type of reaction.
- (ii) If (A) reacts with air on heating that will be the nature of oxide formed?

or

- (iv) Does oxide of (A) react with aqueous NaOH and/or HCl. Give balanced chemical equations.

Continue on next page.....

Click the Following Button to See the Free MS/Solutions

SOLUTIONS

39. Sex determination is the method by which distinction between males and females is established in a species. The sex of an individual is determined by specific chromosomes. These chromosomes are called sex chromosomes. X and Y chromosomes are called sex chromosomes. The normal chromosomes other than the sex chromosomes of an individual are known as autosomes.

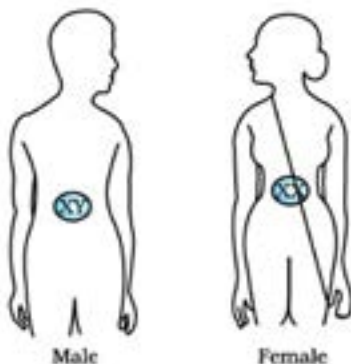

- (i) A normal baby girl receives her X chromosome from whom: mother, father, both mother and father or either from mother or father?
- (ii) Which vital function is not controlled by autosomes?
- (iii) A couple has six daughters. What is the possibility of them having a girl next time?
- or**
- (iv) Do genetic combination of mothers play a significant role in determining the sex of a new born?

□□□□□□

DOWNLOAD INDIA'S BEST STUDY MOBILE APP

- 30 Sample Paper with Solutions
- Chapterwise Question Bank of All Subject
- Previous 15 Years Solved Papers
- NCERT Solutions
- Case Study Questions with full Solutions
- **Word File of Material for Teachers**

Search by **NODIA** on Play Store to Download App

Add 89056 29969 in Your Class Whatsapp Group to Get Link

Click the Following Button to See the Free MS/Solutions

SOLUTIONS

Sample Paper 27

Class X 2023-24

Science (086)

Time: 3 Hours

Max. Marks: 80

General Instructions:

1. This question paper consists of 39 questions in 5 sections.
 2. All questions are compulsory. However, an internal choice is provided in some questions. A student is expected to attempt only one of these questions.
 3. Section A consists of 20 Objective Type questions carrying 1 mark each.
 4. Section B consists of 6 Very Short questions carrying 02 marks each. Answers to these questions should be in the range of 30 to 50 words.
 5. Section C consists of 7 Short Answer type questions carrying 03 marks each. Answers to these questions should be in the range of 50 to 80 words.
 6. Section D consists of 3 Long Answer type questions carrying 05 marks each. Answer to these questions should be in the range of 80 to 120 words.
 7. Section E consists of 3 source-based/case-based units of assessment of 04 marks each with sub-parts.
-

SECTION-A

Select and write one most appropriate option out of the four options given for each of the questions 1 – 20.

1. The image shows the structure of a flower.

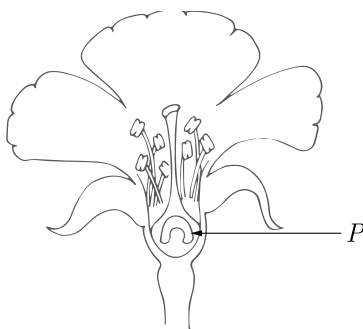

Which process will likely be disturbed or not occur, if labelled part is removed from the flower?

- (a) Transport of pollen
 - (b) Formation of fruit
 - (c) Development of pollen tube
 - (d) Formation of pollen
2. The labelled part is ovule. Removal of ovule results in failure of fertilisation. We know that without fertilisation, formation of fruit will not take place. A cross between a tall plant (TT) and short pea plant (tt) resulted in progeny that were all tall plants because:
 - (a) shortness is the dominant trait.
 - (b) tallness is the dominant trait.
 - (c) height of pea plant is not governed by gene T or t.
 - (d) tallness is the recessive trait.

Click the Following Button to See the Free MS/Solutions

SOLUTIONS

3. The figure given below shows a schematic plan of blood circulation in humans with labels (i) to (iv). Identify the correct label with its functions.

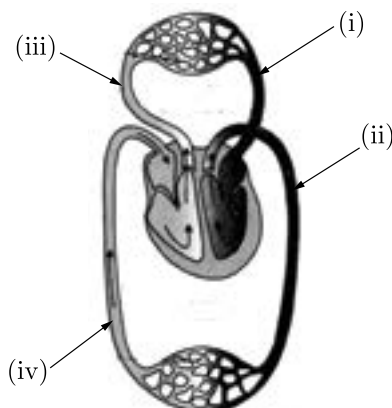

- (a) (i) Pulmonary vein - takes impure blood from body part.
 (b) (ii) Pulmonary artery - takes blood from lung to heart.
 (c) (iii) Aorta - takes blood from heart to body parts.
 (d) (iv) Vena cava takes - blood from body parts to right auricle.
4. Select from the following statement which is true for bases.
- (a) Bases have a pH less than 7.
 (b) Bases are bitter and turn blue litmus red.
 (c) Bases turn pink when a drop of phenolphthalein is added to them.
 (d) Bases are sour and change red litmus to blue.
5. Which three allotropes of carbon, do the given figures represent?

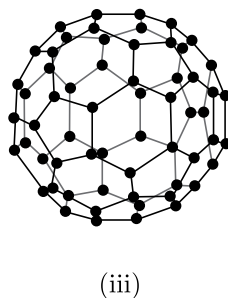
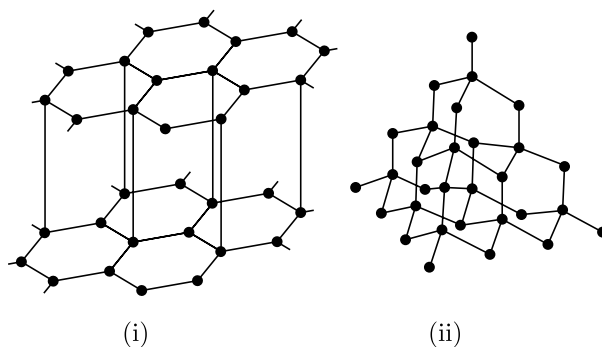

Continue on next page.....

Click the Following Button to See the Free MS/Solutions

SOLUTIONS

	(I)	(II)	(III)
(a)	Diamond	Graphite	Buckminster-Fullerene
(b)	Graphite	Buckminster-Fullerene	Diamond
(c)	Diamond	Buckminster-Fullerene	Graphite
(d)	Graphite	Diamond	Buckminster-Fullerene

6. An electron is entering a region of magnetic field as shown. Given that the magnetic field direction is into the paper. In which direction will the deflection of the electron occur?

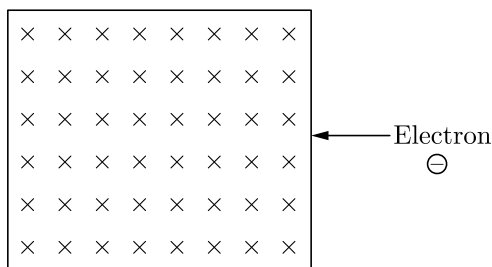

- (a) Out of the paper
 (b) Into the paper
 (c) Towards the top of the paper
 (d) Towards the bottom of the paper
7. A substance X, turns red Litmus blue, it will change methyl orange to :
- (a) pink
 (b) yellow
 (c) colourless
 (d) red
8. Magnetic field is produced by the flow of current in a straight wire. The phenomenon was discovered by:
- (a) Fleming
 (b) Faraday
 (c) Oersted
 (d) Maxwell
9. Why is it important to balance a skeletal chemical equation?
- (a) To verify the law of constant proportion.
 (b) To verify law of conservation of energy.
 (c) To verify the law of conservation of momentum.
 (d) To verify the law of conservation of mass.
10. Which of the following is correct?
- (a) $1 \text{ kWh} = 36 \times 10^6 \text{ J}$
 (b) $1 \text{ watt hour} = 3600 \text{ J}$
 (c) Energy (in kWh)
 (d) $\text{Energy (in kWh)} = \text{power (in W)} \times \text{time (in hr)}$

$$= \frac{\text{V (volt)} \times \text{l(ampere)} \times \text{t(sec)}}{1000}$$

Click the Following Button to See the Free MS/Solutions

SOLUTIONS

11. Three resistances are connected as shown below.

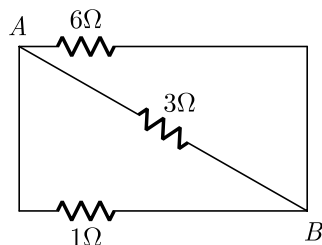

The equivalent resistance between A and B is:

- (a) $\frac{3}{2}\Omega$
 (b) $\frac{2}{3}\Omega$
 (c) $\frac{3}{4}\Omega$
 (d) $\frac{4}{3}\Omega$
12. Marble statues are corroded or stained when they repeatedly come into contact with polluted rain water. Identify the main reason.



- (a) Polluted water is basic in nature hence it reacts with calcium carbonate.
 (b) Decomposition of calcium carbonate to calcium oxide.
 (c) Calcium carbonate dissolves in water to give calcium hydroxide.
 (d) Polluted water is acidic in nature hence it reacts with calcium carbonate.
13. Marble statues are corroded or stained when they repeatedly come into contact with polluted rain water. Polluted rain water is acidic in nature it reacts with calcium carbonate. Involuntary actions in the body are controlled by:
- (a) medulla in midbrain
 (b) medulla in forebrain
 (c) medulla in spinal cord
 (d) medulla in hindbrain
14. The table provides the pH value of four solutions P, Q, R and S :

Solution	pH value
P	2
Q	9
R	5
S	11

Continue on next page.....

Click the Following Button to See the Free MS/Solutions

SOLUTIONS

Which of the following correctly represents the solutions in increasing order of their hydronium ion concentration?

- (a) $P > S > Q > R$
- (b) $P > Q > R > S$
- (c) $S < P < Q < R$
- (d) $S < Q < R < P$

15. Respiratory structures of two different animals a fish and a human being are as shown. Observe (a) and (b) and select one characteristic that holds true for both of them.

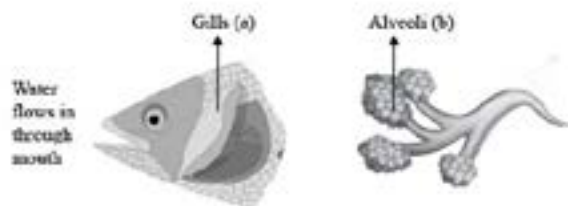

- (a) Both have thin and moist surface for gaseous exchange.
 - (b) Both are placed internally in the body of animal.
 - (c) In both the blood returns to the heart after being oxygenated.
 - (d) Both are poorly supplied with blood vessels to conserve energy.
16. Which of the options in the given table are correct?

Option	Natural Source	Acid Present
(i)	Orange	Oxalic acid
(ii)	Sour milk	Lactic acid
(iii)	Ant sting	Methanoic acid
(iv)	Tamarind	Acetic acid

- (a) (i) and (ii)
- (b) (i) and (iv)
- (c) (ii) and (iii)
- (d) (iii) and (iv)

Question no. 17 to 20 are Assertion-Reasoning based questions.

17. **Assertion (A):** Movement of leaves of sensitive plant is different from movement of a shoot towards light.
Reason (R): Sensitive plant shows seismonastic movements which are due to turgidity of cells whereas the movement of shoot is a tropic movement.
- (a) Both Assertion (A) and Reason (R) are true and Reason (R) is the correct explanation of Assertion (A).
 - (b) Both Assertion (A) and Reason (R) are true but Reason (R) is not the correct explanation of Assertion (A).
 - (c) Assertion (A) is true but Reason (R) is false.
 - (d) Assertion (A) is false but Reason (R) is true.

Continue on next page.....

Click the Following Button to See the Free MS/Solutions

SOLUTIONS

18. **Assertion (A):** A pencil partly immersed in water appears to be bent at the water surface.
Reason (R): Light from different points on the pencil immersed in water refracts and appears to come from a point above the original position.
- Both Assertion (A) and Reason (R) are true and Reason (R) is the correct explanation of Assertion (A).
 - Both Assertion (A) and Reason (R) are true but Reason (R) is not the correct explanation of Assertion (A).
 - Assertion (A) is true but Reason (R) is false.
 - Assertion (A) is false but Reason (R) is true.
19. **Assertion (A):** Testes are located outside the abdominal cavity in the scrotum.
Reason (R): Because sperm formation requires lower temperature than the normal body temperature.
- Both Assertion (A) and Reason (R) are true and Reason (R) is the correct explanation of Assertion (A).
 - Both Assertion (A) and Reason (R) are true but Reason (R) is not the correct explanation of Assertion (A).
 - Assertion (A) is true but Reason (R) is false.
 - Assertion (A) is false but Reason (R) is true.
20. **Assertion (A):** Ionic compounds have high melting and boiling points.
Reason (R): A large amount of energy is required to break the strong inter-ionic attraction in ionic compounds.
- Both Assertion (A) and Reason (R) are true and Reason (R) is the correct explanation of Assertion (A).
 - Both Assertion (A) and Reason (R) are true but Reason (R) is not the correct explanation of Assertion (A).
 - Assertion (A) is true but Reason (R) is false.
 - Assertion (A) is false but Reason (R) is true.

SECTION-B

Question no. 21 to 26 are very short answer questions.

21. An object is placed at a distance of 15 cm from a concave lens of focal length 30 cm. List four characteristics (nature, position, etc.) of the image formed by the lens.

or

An object of height 1.2 m is placed before a concave mirror of focal length 20 cm so that a real image is formed at a distance of 60 cm from it. Find the position of an object. What will be the height of the image formed?

22. In figures (a), (b) and (c), which appears more accurate and why?

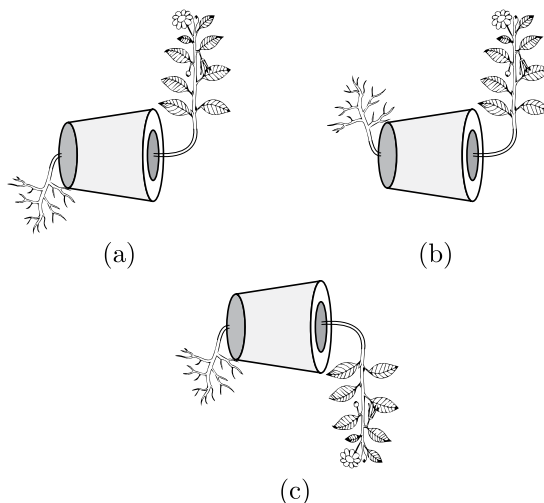

Click the Following Button to See the Free MS/Solutions

SOLUTIONS

23. Consider the food chain :
 Grass \longrightarrow Deer \longrightarrow Lion
 What will happen if all the :
 (i) Lions are removed ?
 (ii) Deers are removed ?

24. (i) In the given diagram, name the parts where (a) pollen grains are produced and (b) pollen grains are transferred.

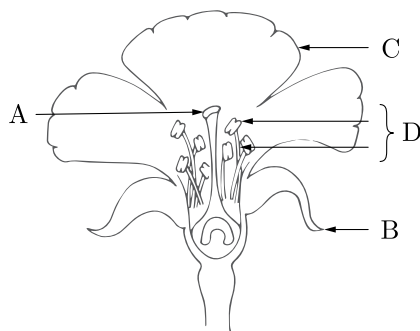

- (ii) What happens to ovule and ovary after fertilisation?

25. What happens when hydrogen gas is passed over the heated copper oxide? Write the chemical equation involved in this reaction.

or

In the arrangement shown below there are three test tubes marked A, B and C. Few clean iron nails are placed in these tubes. Water is poured in test tube A, boiled distilled water and 1 mL of oil are poured in test tube B and anhydrous calcium chloride is added in test tube C.

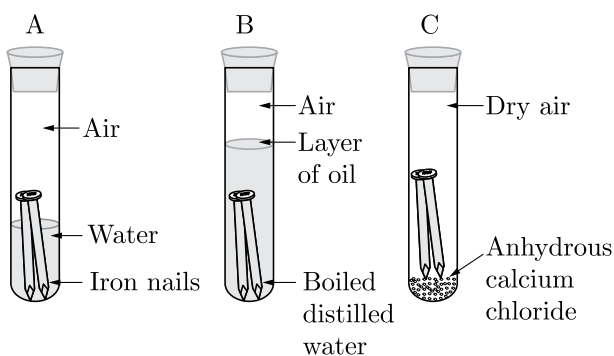

What are the two observations that can be observed after a few days from the given arrangement?

26. Mustard was growing in two fields A and B. While field A produced brown coloured seeds, field B produced yellow coloured seeds.
 It was observed that in field A, the offspring showed only the parental trait for consecutive generations, whereas in field B, majority of the off-springs showed a variation in the progeny.
 What are the probable reasons for these?

SECTION-C

Question no. 27 to 33 are short answer questions.

27. (i) Complete the following table :

Formula	Oxygen	Ozone
	(i)	(ii)
Benefits to biotic component	(iii)	(iv)

(ii) How is ozone formed at the higher levels of atmosphere?

28. A 10 cm tall object is placed perpendicular to the principal axis of a convex lens of focal length 12 cm. The distance of the object from the lens is 18 cm. Find the nature, position and size of the image formed.

29. A V-I graph for a nichrome wire is given below. What do you infer from this graph? Draw a labelled circuit diagram to obtain such a graph.

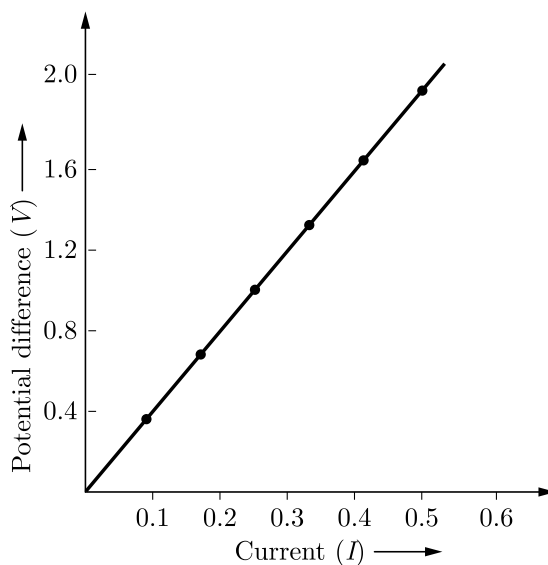

or

- (i) What is the meaning of electric power of an electrical device? Write its S.I. unit.
 (ii) An electric kettle of 2 kW is used for 2h. Calculate the energy consumed in (a) kilowatt hour and (b) joules.

Continue on next page.....

Click the Following Button to See the Free MS/Solutions

SOLUTIONS

30. Observe the given figure and answer the following questions:

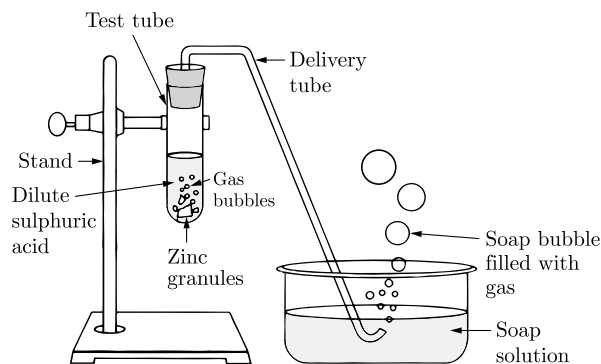

- (i) Which gas is produced by the reaction of zinc and dil. sulphuric acid?
 - (ii) How will you test for the presence of the gas produced?
 - (iii) Name the salt produced when zinc metal reacts with sodium hydroxide solution.
 - (iv) Can all bases react with active metals?
31. Draw ray diagrams for the following cases when a ray of light:
- (i) passing through centre of curvature of a concave mirror is incident on it.
 - (ii) parallel to principal axis is incident on convex mirror.
 - (iii) is passing through focus of a concave mirror incident on it.
32. (i) Identify any two parts from the given diagram which carry oxygenated and deoxygenated blood.

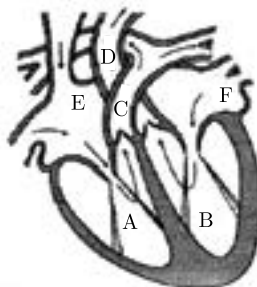

- (ii) Explain the process of double circulation with the help of a flow chart.

or

List in tabular form three distinguishing features between autotrophic nutrition and heterotrophic nutrition.

33. In an experimental set-up, 10 mL of copper sulphate is taken in both the test tubes A and B. Iron nails are dipped in test tube B for about 20 minutes. The given figure shows the comparison of iron nails and copper sulphate solutions before and after the reaction. Observe the given figure and answer the questions that follow:

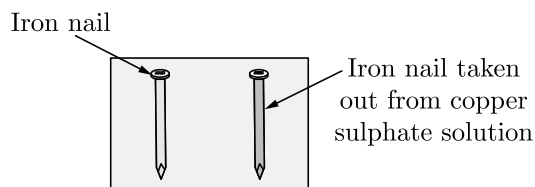

Continue on next page.....

Click the Following Button to See the Free MS/Solutions

SOLUTIONS

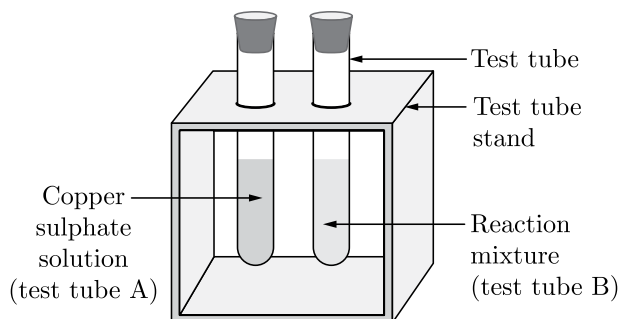

- (i) What changes in the colour of iron nail and copper sulphate solution do you observe after keeping the iron nail dipped in copper sulphate solution for about 20 minutes?
- (ii) Why does the blue colour of copper sulphate fade by adding iron nail in it?
- (iii) Write the chemical reaction involved. Name the type of reaction in the above activity.

SECTION-D

Question no. 34 to 36 are Long answer questions.

34.
 - (i) List in tabular form three differences between binary fission and multiple fission.
 - (ii) What happens when a mature Spirogyra filament attains considerable length?
 - (iii) List two disadvantages of vegetative propagation.

or

 - (i) Budding, fragmentation and regeneration, all are considered as asexual mode of reproduction. Why?
 - (ii) With the help of neat diagram, explain the process of regeneration in Planaria.
 - (iii) Draw a labelled diagram in proper sequence to show budding in Hydra.

35.
 - (i) Name two oxidising agents that are used for the conversion of alcohols to acids. Distinguish between ethanol and ethanoic acid on the basis of (a) litmus test, and (b) reaction with sodium hydrogen carbonate.
 - (ii) The table shows the electronic structures of four elements.

Element	Electronic Structure
P	2, 6
Q	2, 8, 1
R	2, 8, 7
S	2, 8, 8

- (a) Identify which element(s) will form covalent bonds with carbon.
 - (b) 'Carbon reacts with an element in the above table to form several compounds.' Give suitable reason.
- or**
- (i) What is a homologous series ? Find the difference in molecular mass between the two consecutive members of a homologous series. State how in a homologous series of carbon compounds the following properties vary will increase in molecular mass :
 - (a) Melting and boiling points.
 - (b) Chemical properties.
 - (ii) Draw the possible isomers of the compound with molecular formula C_3H_6O and also give their electron dot structures.

Continue on next page.....

Click the Following Button to See the Free MS/Solutions

SOLUTIONS

36. (i) Suppose your parents have constructed a two room house and you want that in the living room there should be a provision of one electric bulb, one electric fan, a refrigerator and a plug point for appliances of power up to 2 kW. Draw a circuit diagram showing electric fuse and earthing as safety devices.
 (ii) The given magnet is divided into three parts A, B and C.

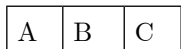

Name the parts where the strength of magnetic field is:

- (a) maximum
- (b) minimum

How will the density of magnetic field lines differ at these parts?

SECTION-E

Question no. 37 to 39 are case-based/data-based questions with 2 to 3 short sub-parts. Internal choice is provided in one of these sub-parts.

37. Arteries, veins and capillaries are blood vessels through which blood flows in our body. Arteries carry blood from heart to different parts of the body whereas veins deliver blood back to the heart. Arteries are connected to veins by thin capillaries.
- (i) Which two chambers of the human heart have arteries connected to them?
 - (ii) What are capillaries?
 - (iii) What is blood pressure? How is it measured?

or

Study the graph below that represents the blood pressure in various blood vessels of the circulatory system.

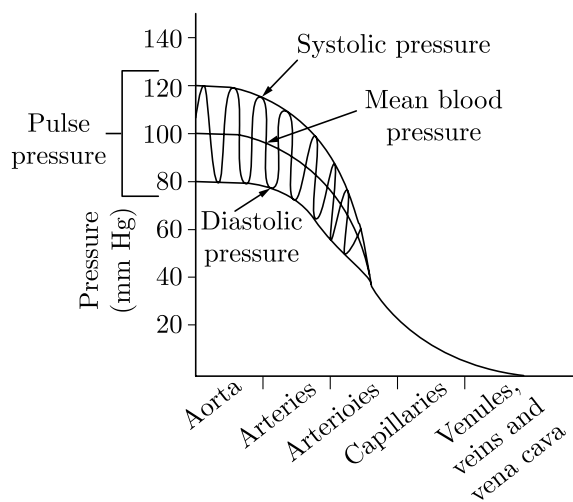

Why is blood pressure higher in our arteries than in our veins?

Continue on next page.....

Click the Following Button to See the Free MS/Solutions

SOLUTIONS

38. Homologous series is a series of compounds with similar chemical properties and same functional group differing from the successive member by $-\text{CH}_2$ or 14 mass units. Members of a homologous series show a gradual change in the physical properties (such as melting point, boiling point etc.) with the increase in molecular formula in the series.
- (i) What is the difference between two consecutive members in a homologous series in alkanes in terms of
- Molecular mass
 - Number of atoms of elements?
- (ii)
- Write the formula and IUPAC name of the next homologue of $\text{CH}_3\text{CH}_2\text{OH}$.
 - Which two of the following organic compounds belong to the same homologous series?
 C_2H_6 , $\text{C}_2\text{H}_6\text{O}$, $\text{C}_2\text{H}_6\text{O}_2$, CH_4O

or

Study the graph below that represents the boiling points of alcohols compared with alkanes.

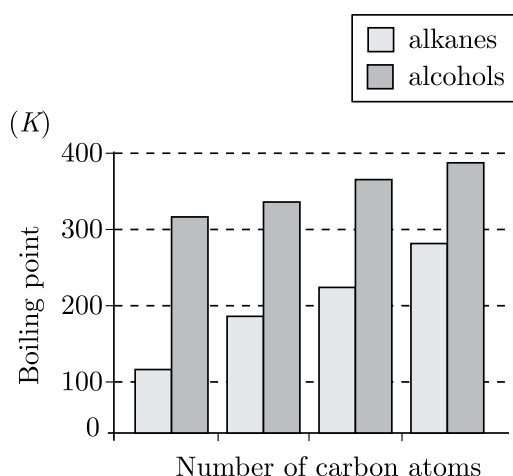

What do you depict from the given graph?

39. Sumati wanted to see the stars of the night sky. She knows that she needs a telescope to see those distant stars. She finds out that the telescopes, which are made of lenses, are called refracting telescopes and the ones which are made of mirrors are called reflecting telescopes.

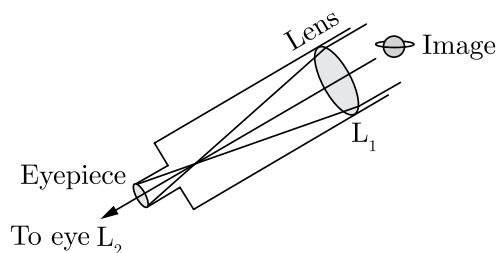

So, she decided to make a refracting telescope. She bought two lenses, L_1 and L_2 , out of which L_1 was bigger and L_2 was smaller. The larger lens gathers and bends the light, while the smaller lens magnifies the image. Big, thick lenses are more powerful. So to see far away, she needed a big powerful lens. Unfortunately, she realised that a big lens is very heavy.

Continue on next page.....

Click the Following Button to See the Free MS/Solutions

SOLUTIONS

Heavy lenses are hard to make and difficult to hold in the right place. Also since the light is passing through the lens, the surface of the lens has to be extremely smooth. Any flaws in the lens will change the image. It would be like looking through a dirty window.

- (i) Based on the diagram shown, what kind of lenses would Sumati need to make the telescope?
- (ii) What is the formula of magnification obtained with a lens?
- (iii) Sumati did some preliminary experiment with the lenses and found out that the magnification of the eyepiece L_2 is 3. If in her experiment with L_2 she found an image at 24 cm from the lens, at what distance did she put the object?

or

If the powers of the lenses L_1 and L_2 are in the ratio of 4 : 1, what would be the ratio of the focal length of L_1 and L_2 ?

□□□□□□

DOWNLOAD INDIA'S BEST STUDY MOBILE APP

- 30 Sample Paper with Solutions
- Chapterwise Question Bank of All Subject
- Previous 15 Years Solved Papers
- NCERT Solutions
- Case Study Questions with full Solutions
- **Word File of Material for Teachers**

Search by **NODIA** on Play Store to Download App

Add 89056 29969 in Your Class Whatsapp Group to Get Link

Click the Following Button to See the Free MS/Solutions

SOLUTIONS

Sample Paper 28

Class X 2023-24

Science (086)

Time: 3 Hours

Max. Marks: 80

General Instructions:

1. This question paper consists of 39 questions in 5 sections.
 2. All questions are compulsory. However, an internal choice is provided in some questions. A student is expected to attempt only one of these questions.
 3. Section A consists of 20 Objective Type questions carrying 1 mark each.
 4. Section B consists of 6 Very Short questions carrying 02 marks each. Answers to these questions should be in the range of 30 to 50 words.
 5. Section C consists of 7 Short Answer type questions carrying 03 marks each. Answers to these questions should be in the range of 50 to 80 words.
 6. Section D consists of 3 Long Answer type questions carrying 05 marks each. Answer to these questions should be in the range of 80 to 120 words.
 7. Section E consists of 3 source-based/case-based units of assessment of 04 marks each with sub-parts.
-

SECTION-A

Select and write one most appropriate option out of the four options given for each of the questions 1 – 20.

1. In which of the following diagrams is the path of a ray of light passing through a glass prism shown correctly?

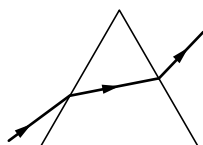

(I)

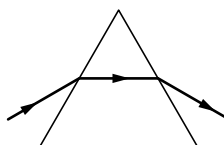

(II)

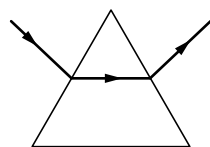

(III)

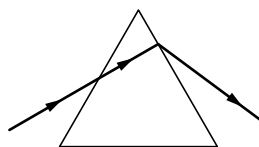

(IV)

- (a) I
(b) II
(c) III
(d) IV

Continue on next page.....

Click the Following Button to See the Free MS/Solutions

SOLUTIONS

2. Common salt besides being used in kitchen can also be used as the raw material for making
1. washing soda
 2. bleaching powder
 3. baking soda
 4. slaked lime
- (a) 1 and 2
(b) 1, 2 and 4
(c) 1 and 3
(d) 1, 3 and 4
3. Which is the correct sequence of the components of a reflex arc ?
- (a) Receptors → Muscles → Sensory neuron → Motor neuron → Spinal cord
(b) Receptors → Motor neuron → Spinal cord → Sensory neuron → Muscle
(c) Receptors → Spinal cord → Sensory neuron → Motor neuron → Muscle
(d) Receptors → Sensory neuron → Spinal cord → Motor neuron → Muscle.
4. An aqueous solution turns red litmus solution blue.

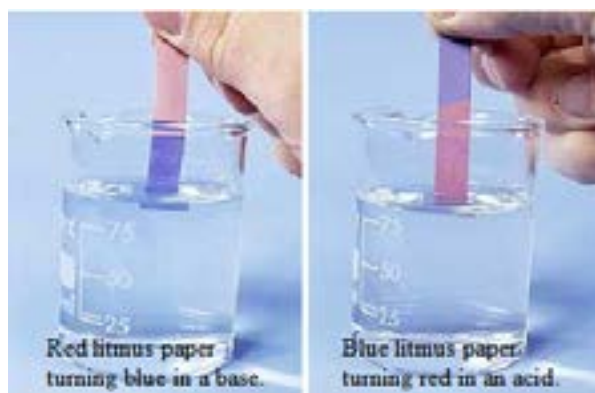

Excess addition of which of the following solution would reverse the change?

- (a) Baking powder
(b) Lime
(c) Ammonium hydroxide solution
(d) Hydrochloric acid
5. The path of a ray of light coming from air passing through a rectangular glass slab traced by four students are shown in figure. Which one of them is correct?

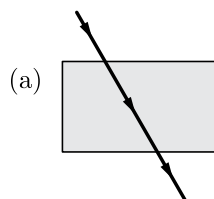

Continue on next page.....

Click the Following Button to See the Free MS/Solutions

SOLUTIONS

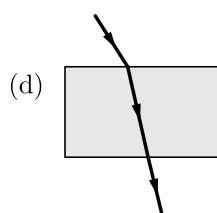
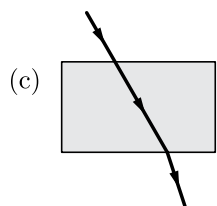
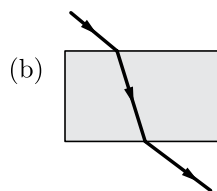

6. The image formed by a concave mirror is observed to be virtual, erect and larger than the object. Where should be the position of the object?
- Between the principal focus and the centre of curvature
 - At the centre of curvature
 - Beyond the centre of curvature
 - Between the pole of the mirror and its principal focus.
7. Which of the following statements are usually correct for carbon compounds? These
- are good conductors of electricity
 - are poor conductors of electricity
 - have strong forces of attraction between their molecules
 - do not have strong forces of attraction between their molecules.
- (i) and (iii)
 - (ii) and (iii)
 - (i) and (iv)
 - (ii) and (iv)
8. Choose the forms in which most plants absorb nitrogen:
- Atmospheric nitrogen
 - Proteins
 - Nitrates and nitrites
 - Urea
- Choose the correct option.
- 1 and 4
 - 3 and 4
 - 1 and 2
 - 2 and 3

Continue on next page.....

Click the Following Button to See the Free MS/Solutions

SOLUTIONS

9. Which reaction is used in photography?
- (a) $\text{CaO} + \text{H}_2\text{O} \longrightarrow \text{Ca}(\text{OH})_2 + \text{Heat}$
- (b) $2\text{FeSO}_4 \xrightarrow{\text{Heat}} \text{Fe}_2\text{O}_3 + \text{SO}_2 + \text{SO}_3$
- (c) $2\text{Cu} + \text{O}_2 \longrightarrow 2\text{CuO}$
- (d) $2\text{AgBr} \xrightarrow{\text{sunlight}} 2\text{Ag} + \text{Br}$
10. During the process of photosynthesis, absorption of light energy is done by



- (a) Leaf
- (b) Midrib
- (c) Vein
- (d) Chlorophyll
11. The correct sequence of organs in the male reproductive system for transport of sperms is
- (a) testis \rightarrow vas deferens \rightarrow urethra
- (b) testis \rightarrow ureter \rightarrow urethra
- (c) testis \rightarrow urethra \rightarrow ureter
- (d) testis \rightarrow vas deferens \rightarrow ureter
12. Which of the following is/are correct for a balanced chemical equation?

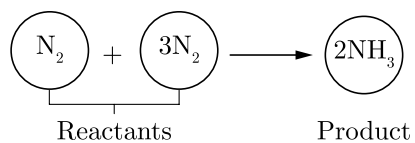

- It is based on law of conservation of mass.
 - The physical states makes the chemical reaction less informative.
- (a) Only 1
- (b) Only 2
- (c) Both 1 and 2
- (d) Neither 1 nor 2

Continue on next page.....

Click the Following Button to See the Free MS/Solutions

SOLUTIONS

13. Which one of the following metals do not react with cold as well as hot water?
- Na
 - Ca
 - Mg
 - Fe
14. Which among the following statements are true for unisexual flowers?
- They possess both stamen and pistil
 - They possess either stamen or pistil
 - They exhibit cross pollination
 - Unisexual flowers possessing only stamens cannot produce fruits
- (i) and (iv)
 - (ii), (iii) and (iv)
 - (iii) and (iv)
 - (i), (iii) and (iv)
15. Angle of deviation depends on:
- Angle of prism
 - Nature of material of prism
 - Angle of incidence on the prism
 - All of the above
- 16.

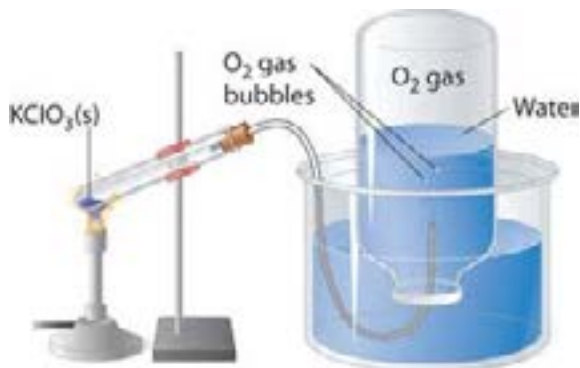

The following reaction is used for the preparation of oxygen gas in the laboratory

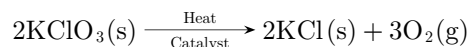

Which of the following statement(s) is(are) correct about the reaction?

- It is a decomposition reaction and endothermic in nature.
- It is a combination reaction.
- It is a decomposition reaction and accompanied by release of heat.
- It is a photochemical decomposition reaction and exothermic in nature.

Question no. 17 to 20 are Assertion - Reasoning based questions.

17. **Assertion :** Corrosion of iron is commonly known as rusting.

Reason : Corrosion of iron occurs in presence of water and air.

- Both Assertion and Reason are True and Reason is the correct explanation of the Assertion.
- Both Assertion and Reason are True but Reason is not the Correct explanation of the Assertion.
- Assertion is True but the Reason is False.
- Both Assertion and Reason are False.

Click the Following Button to See the Free MS/Solutions

SOLUTIONS

18. **Assertion :** Cytokinins are present in highest concentration in fruits and seeds.
Reason : Cytokinins are responsible for promoting cell division.
- (a) Both assertion (A) and reason (R) are true and reason (R) is the correct explanation of assertion (A).
 - (b) Both assertion (A) and reason (R) are true but reason (R) is not the correct explanation of assertion (A).
 - (c) Assertion (A) is true but reason (R) is false.
 - (d) Assertion (A) is false but reason (R) is true.
19. **Assertion :** Liver is known as the largest gland of the body.
Reason : It secretes salivary amylase.
- (a) Both Assertion and Reason are true and Reason is the correct explanation of Assertion.
 - (b) Both Assertion and Reason are true but Reason is not the correct explanation of Assertion.
 - (c) Assertion is true but Reason is false.
 - (d) Assertion is false but Reason is true.
20. **Assertion :** When the length of a wire is doubled, then its resistance also gets doubled.
Reason : The resistance of a wire is directly proportional to its length.
- (a) Both assertion (A) and reason (R) are true and reason (R) is the correct explanation of assertion (A).
 - (b) Both assertion (A) and reason (R) are true but reason (R) is not the correct explanation of assertion (A).
 - (c) Assertion (A) is true but reason (R) is false.
 - (d) Assertion (A) is false but reason (R) is true.

SECTION-B

Question no. 21 to 26 are very short answer questions.

21. A metal compound A reacts with dilute sulphuric acid to produce a gas which extinguishes a burning candle. Identify the compound A and the gas produced. Write a balanced chemical equation for the reaction if one of the compounds formed in the reaction is sodium sulphate.
- or**
- How does the enamel of the teeth undergo damage due to the eating of chocolates and sweets ? What should be done to prevent it.
22. Differentiate between motor neuron and sensory neuron.
23. Is it correct to say that if fertilization of the egg occurs on a full moon night, the child produced will be a male ? Give reason.
24. Why is DNA copying necessary during reproduction?
25. Name the type of mirror used in a solar furnace. How is high temperature achieved by this device ?
- or**
- What is meant by refractive index ? If the speed of light in a medium is $\frac{2}{3}$ rd of the speed of light in vacuum, find the refractive index of that medium.
26. What will happen to grass-lands if all the grazers/herbivores are removed from there ?

Click the Following Button to See the Free MS/Solutions

SOLUTIONS

SECTION-C

Question no. 27 to 33 are short answer questions.

27. What is meant by refining of metals? Describe the electrolytic refining of copper with a neat labelled diagram.
28. Name the plant Mendel used for his experiment. What type of progeny was obtained by Mendel in F_1 and F_2 generations when he crossed the tall and short plants? Write the ratio he obtained in F_2 generation plants.
29. Distinguish between the acquired traits and the inherited traits in tabular form, giving one example for each.
- or**
- How did Mendel's experiments show that different traits are inherited independently? Explain.
30. (i) Least distance of distinct vision of a long-sighted person is 40 cm. He wishes to reduce it to 25 cm by using spectacles. Find the power and nature of the lens used by him.
(ii) Draw a ray diagram to show the correction of the defect by using an appropriate lens.
31. The near point of a person suffering from hypermetropia is 75 cm. Calculate the focal length and power of the lens required to enable him to read the newspaper which is kept at 25 cm from the eye.
32. (a) Two conductors A and B of resistances $5\ \Omega$ and $10\ \Omega$ respectively can be arranged in parallel and later on in series. In each arrangement, the total voltage applied across it is 20 volts. In which arrangement will the voltage across A and B be the same and in which case will the current flowing through A and B be the same ?
(b) Calculate the total resistance for each arrangement.
- or**
- A metallic coil, connected to a 220 V supply, has a resistance of 110 ohm (while hot). How long will it take for this coil to heat 1 kg of water from 20°C to 70°C ? Assume that whole of the heat produced by the coil is taken up by water. (Specific heat of water = $4186\ \text{J/kg}^\circ\text{C}$)
33. (i) What is the height of ozone from the equator ?
(ii) Name the rays against which ozone layer provides protection.
(iii) Name one effect of depletion of ozone.

SECTION-D

Question no. 34 to 36 are Long answer questions.

34. What is plaster of paris? How is plaster of paris prepared ? Write equation of the reaction involved. What happens when water is added to plaster of paris? Write an equation to show the reaction between plaster of paris and water.
- or**
- Give suitable reasons for the following statements :
- (a) Rain water conducts electricity but distilled water does not.
(b) We feel burning sensation in the stomach when we overeat.
(c) A tarnished copper vessel regains its shine when rubbed with lemon.
(d) The crystals of washing soda change to white powder on exposure to air.
(e) An aqueous solution of sodium chloride is neutral but an aqueous solution of sodium is basic.
35. Describe the structure of a sieve tube. Name the cells which are present along sieve tubes in the phloem tissue. Draw a labelled diagram of phloem tissue.
- or**
- What is translocation ? Name the cells involved in the transport of food in plants. What are the steps involved in the translocation of food in plants ?

Click the Following Button to See the Free MS/Solutions

SOLUTIONS

36. (a) What is a solenoid ? Draw the pattern of magnetic field lines around a current carrying solenoid.
(b) What is the pattern of field lines inside a solenoid? What do they indicate ?
(c) How is the magnetic field produced in a solenoid used ?

SECTION-E

Question no. 37 to 39 are case-based/data -based questions with 2 to 3 short sub-parts. Internal choice is provided in one of these sub-parts.

37. Corrosion is the phenomenon of deterioration of surface of metal in presence of air and moisture. It is a natural process and in the presence of a moist atmosphere, chemically active metals get corroded. This is oxidation reaction. Rusting is the process where iron corrodes due to exposure to the atmosphere. The main circumstance of corrosion occurs with iron because it is a structural material in construction, bridges, buildings, rail transport, ships, etc. Aluminium is also an important structural metal, but even aluminium undergoes oxidation reactions. However, aluminium doesn't corrode or oxidize as rapidly as its reactivity suggests. An alloy of aluminium or any other metal like magnesium can make aluminium stronger and harder. Copper (Cu) corrodes and forms a basic green carbonate and lead corrodes to form a white lead oxide or carbonate.
- (i) What is rusting?
(ii) Which two metals do not corrode easily?
(iii) List two properties of alloys.
- or**
- (iv) What is the effect of corrosion on electrical conductivity ?

38. Carpel is present at the centre of a flower and is the female reproductive part. It is made of three parts. The swollen bottom part is the ovary, the middle elongated part is the style and the terminal part which may be sticky is the stigma. The ovary contains ovules and each ovule has an egg cell. The male germ-cell produced by pollen grain fuses with the female gamete present in the ovule. This fusion of the germ-cells or fertilization gives us the zygote which is capable of growing into a new plant. Thus, the pollen needs to be transferred from the stamen to stigma. If this transfer of pollen occurs in the same flower, it is referred to as self-pollination. On the other hand, if the pollen is transferred from one flower to another, it is known as cross-pollination. This transfer of pollen from one flower to another is achieved by agents like wind, water or animals. After the pollen lands on a suitable stigma, it has to reach the female germ-cells which are in the ovary. For this, a tube grows out of the pollen grain and travels through the style to reach the ovary.

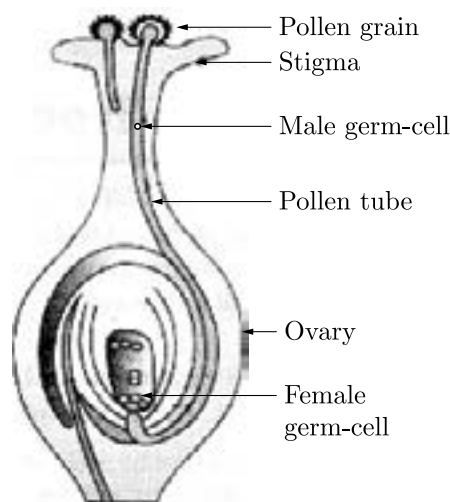

Continue on next page.....

Click the Following Button to See the Free MS/Solutions

SOLUTIONS

- (i) What is present at the centre of the flower?
- (ii) How many parts does the carpel have?
- (iii) What do you mean by cross-pollination?

or

- (iv) What do you mean by self-pollination?

39. Convex mirror is used as a rear view mirror in vehicles. Since the image of the object formed is small in size, the field of view is increased. Convex mirror is also used in street lights to diverge light over a large area.



- (i) In driver's mirror, what type of image is formed behind the vehicle ?
 - (ii) What can you say about field of view of a convex mirror ?
- or
- (iii) A convex mirror is used to form the image of an object. What is the nature of formed image ?

□□□□□□

DOWNLOAD INDIA'S BEST STUDY MOBILE APP

- 30 Sample Paper with Solutions
- Chapterwise Question Bank of All Subject
- Previous 15 Years Solved Papers
- NCERT Solutions
- Case Study Questions with full Solutions
- **Word File of Material for Teachers**

Search by **NODIA** on Play Store to Download App

Add 89056 29969 in Your Class Whatsapp Group to Get Link

Click the Following Button to See the Free MS/Solutions

SOLUTIONS

Sample Paper 29

Class X 2023-24

Science (086)

Time: 3 Hours

Max. Marks: 80

General Instructions:

1. This question paper consists of 39 questions in 5 sections.
2. All questions are compulsory. However, an internal choice is provided in some questions. A student is expected to attempt only one of these questions.
3. Section A consists of 20 Objective Type questions carrying 1 mark each.
4. Section B consists of 6 Very Short questions carrying 02 marks each. Answers to these questions should be in the range of 30 to 50 words.
5. Section C consists of 7 Short Answer type questions carrying 03 marks each. Answers to these questions should be in the range of 50 to 80 words.
6. Section D consists of 3 Long Answer type questions carrying 05 marks each. Answer to these questions should be in the range of 80 to 120 words.
7. Section E consists of 3 source-based/case-based units of assessment of 04 marks each with sub-parts.

SECTION-A

Select and write one most appropriate option out of the four options given for each of the questions 1 – 20.

1. The diagram shows a vertical section through the heart.

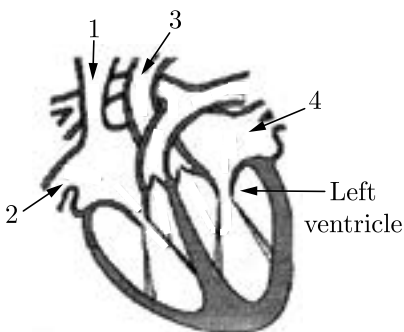

What are the functions of the numbered blood vessels?

S. No.	Carries blood to body	Carries blood to lungs	Carries blood from lungs	Carries blood from body
(a)	1	2	3	4
(b)	1	3	4	2
(c)	2	4	3	1
(d)	3	1	4	2

Continue on next page.....

Click the Following Button to See the Free MS/Solutions

SOLUTIONS

2. In the reaction of iron with copper sulphate solution:



Which option in the given table correctly represents the substance oxidised and the reducing agent?

Option	Substance oxidised	Reducing agent
(a)	Fe	Fe
(b)	Fe	FeSO ₄
(c)	Cu	Fe
(d)	CuSO ₄	Fe

3. The temperature of a conductor is increased. The graph best showing the variation of its resistance is:

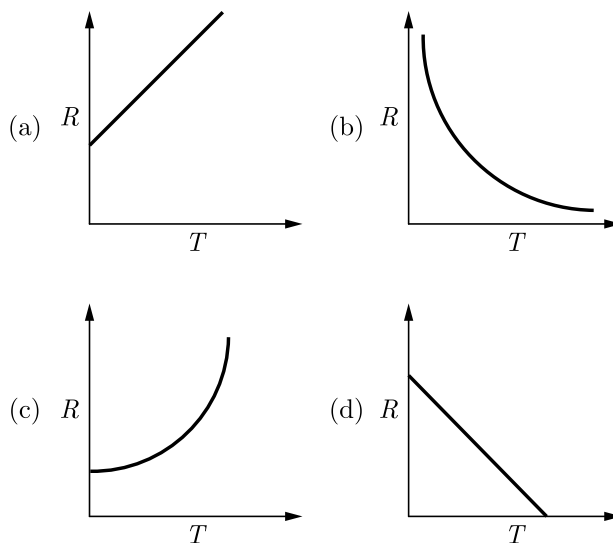

4. A plant is kept in the dark for two days. A leaf is used in an experiment to investigate the effect of two factors on photosynthesis as shown in the diagram.

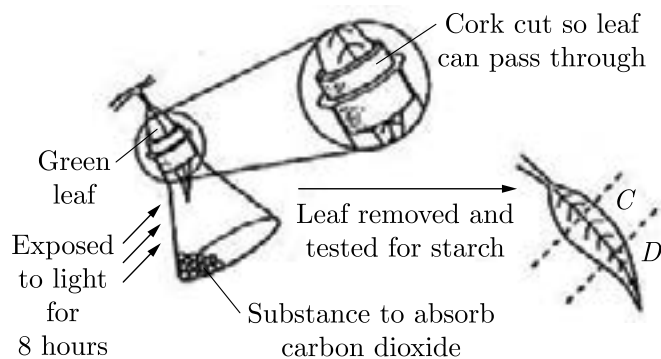

Continue on next page.....

Click the Following Button to See the Free MS/Solutions

SOLUTIONS

What are the colours of Q and R, when the leaf is tested for starch, using iodine solution?

S. No.	Q	R
(a)	Blue/black	Brown
(b)	Brown	Brown
(c)	Blue/black	Blue/black
(d)	Brown	Blue/black

5. Study the given figure depicting locations of several endocrine glands in a human female identify the labelled glands and select the option with any four correct labels.

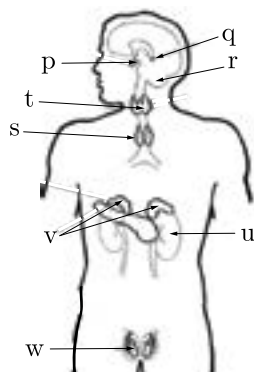

- (a) p-Pituitary, t-Thyroid, u-Adrenal, w-Ovary
 (b) u-pancreas, w-Ovary, p-Hypothalamus, q-Pineal
 (c) q-Pituitary, t-adrenal, p-Hypothalamus, v-Pancreas
 (d) s-Parathyroid, q-Pineal, v-Ovary, u-Thyroid
6. The image shows the process of vegetative propagation in a plant.

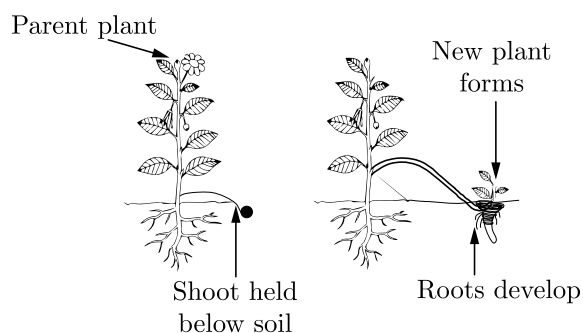

The shoot of the parent plant is pushed below the soil that results in growth of a new plant. What is the advantage of this process?

- (a) This helps grow plants without adding extra manure
 (b) This result in plant of different flowers
 (c) This allows growth of plants with new genetic composition
 (d) This eliminates the need of producing plant using seeds

Continue on next page.....

Click the Following Button to See the Free MS/Solutions

SOLUTIONS

7. A diagram is given below:

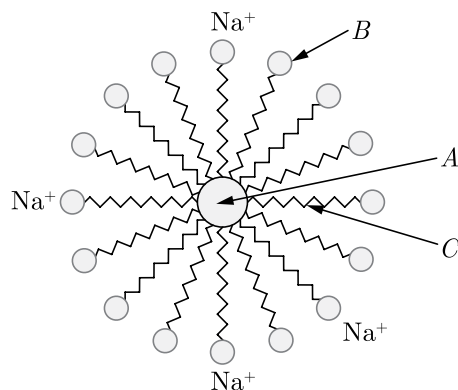

The statement which defines the diagram and its parts is:

- (a) This is an ideal setting of micelle formation with A = hydrophobic end. B = hydrophilic end and C = oil droplet.
- (b) This is an ideal setting of micelle formation with A = Hydrophilic end, B = oil droplet and C = Hydrophobic end.
- (c) This is an ideal setting of micelle formation with A = oil droplet, B = hydrophobic end and C = hydrophilic end.
- (d) This is an ideal setting of micelle formation with A = oil droplet, B = hydrophilic end and C = hydrophobic end.
8. Which of the given options correctly represents the parent acid and base of calcium carbonate?

Option	Parent acid	Parent base
(a)	HCl	NaOH
(b)	H_2CO_3	$\text{Ca}(\text{OH})_2$
(c)	H_3PO_3	CaSO_4
(d)	H_2SO_4	CaSO_4

9. During the preparation of hydrogen chloride gas on a humid day, the gas is usually passed through the guard tube containing calcium chloride. The role of calcium chloride taken in the guard tube is to:
- (a) moisten the gas
- (b) absorb the evolved gas
- (c) absorb Cl^- ion from the evolved gas
- (d) absorb moisture from the gas
10. A solenoid's magnetic field will not increase when:
- (a) a soft iron core is inserted inside the solenoid
- (b) the magnitude of current will increase
- (c) the conductor is kept closed
- (d) a soft aluminium core is inserted inside the solenoid

Continue on next page.....

Click the Following Button to See the Free MS/Solutions

SOLUTIONS

11. A student learns that magnetic field strength around a bar magnet is different at every point. Which diagram shows the correct magnetic field lines around a bar magnet?

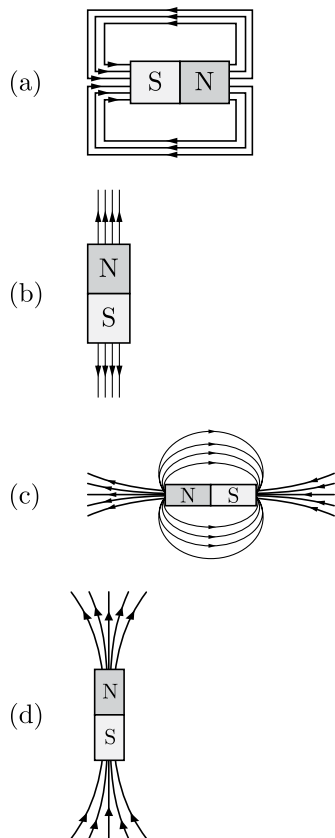

12. The diagram shows the reaction between metal and dil. hydrochloric acid.

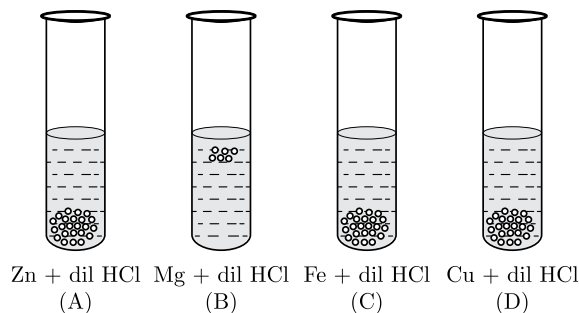

What is the reason for different behaviour of Mg in test tube B?

- (a) Mg reacts with dil. HCl to produce H_2 gas which helps in floating
- (b) Mg is lighter element than dil. HCl
- (c) Mg reacts with dil. HCl to produce CO_2 gas which helps in floating
- (d) Mg reacts with di. HCl to produce N_2 gas which helps in floating

Continue on next page.....

Click the Following Button to See the Free MS/Solutions

SOLUTIONS

13. The resistance of a wire of length 300 m and cross-sectional area 1.0 mm^2 , made of material of resistivity $1.0 \times 10^{-7} \Omega\text{m}$ is:
- 3Ω
 - 2Ω
 - 30Ω
 - 20Ω
14. Refer to the given figure showing a cross between a tall and a short variety of a plant species.

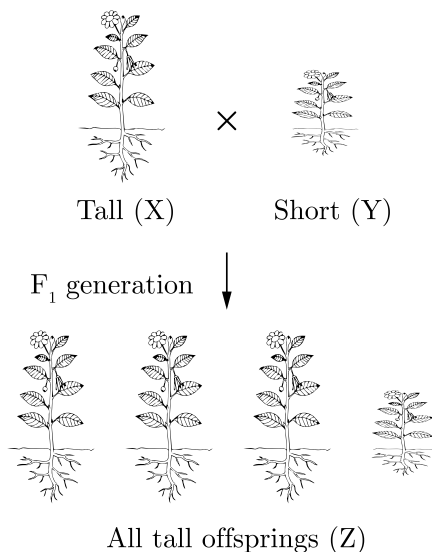

What could be genotype of X, Y and Z in the given figure?

	X	Y	Z
(a)	TT	tt	Tt
(b)	Tt	Tt	Tt
(c)	Tt	Tt	TT
(d)	TT	tt	TT

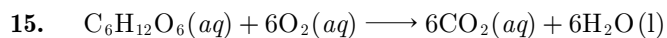

The above reaction is a/an:

- endothermic reaction
- displacement reaction
- neutralisation reaction
- exothermic reaction

Continue on next page.....

Click the Following Button to See the Free MS/Solutions

SOLUTIONS

16. The graph given below depicts a neutralisation reaction (acid + alkali \longrightarrow salt + water). The pH of a solution changes as we add excess of acid to an alkali.

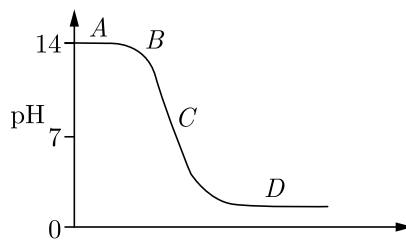

Volume of acid added

Which letter denotes the area of the graph where both acid and salt are present?

- (a) B
- (b) A
- (c) D
- (d) C

Question no. 17 to 20 are Assertion-Reasoning based questions.

17. **Assertion (A):** Cerebellum controls the coordination of body movement and posture.
Reason (R): Medulla oblongata controls and regulates the centre for coughing, sneezing and vomiting.
- (a) Both Assertion (A) and Reason (R) are true and Reason (R) is the correct explanation of Assertion (A).
 - (b) Both Assertion (A) and Reason (R) are true but Reason (R) is not the correct explanation of Assertion (A).
 - (c) Assertion (A) is true but Reason (R) is false.
 - (d) Assertion (A) is false but Reason (R) is true.
18. **Assertion (A):** At high temperatures, metal wires have a greater chance of short circuiting.
Reason (R): Both resistance and resistivity of a material vary with temperature.
- (a) Both Assertion (A) and Reason (R) are true and Reason (R) is the correct explanation of Assertion (A).
 - (b) Both Assertion (A) and Reason (R) are true but Reason (R) is not the correct explanation of Assertion (A).
 - (c) Assertion (A) is true but Reason (R) is false.
 - (d) Assertion (A) is false but Reason (R) is true.
19. **Assertion (A):** The transfer of pollen grains from the anther of a stamen to the stigma of a carpel is called pollination.
Reason (R): Pollination is done by insects, birds, wind and water.
- (a) Both Assertion (A) and Reason (R) are true and Reason (R) is the correct explanation of Assertion (A).
 - (b) Both Assertion (A) and Reason (R) are true but Reason (R) is not the correct explanation of Assertion (A).
 - (c) Assertion (A) is true but Reason (R) is false.
 - (d) Assertion (A) is false but Reason (R) is true.

Continue on next page.....

Click the Following Button to See the Free MS/Solutions

SOLUTIONS

20. **Assertion (A):** Quicklime reacts vigorously with water releasing a large amount of heat.
Reason (R): A solution of quicklime is used for whitewashing walls.
- (a) Both Assertion (A) and Reason (R) are true and Reason (R) is the correct explanation of Assertion (A).
(b) Both Assertion (A) and Reason (R) are true but Reason (R) is not the correct explanation of Assertion (A).
(c) Assertion (A) is true but Reason (R) is false.
(d) Assertion (A) is false but Reason (R) is true.

SECTION-B

Question no. 21 to 26 are very short answer questions.

21. A person is unable to see distinctly the objects closer than 1m. Name the defect of vision he is suffering from. Draw ray diagrams to illustrate the cause of the defect and its correction by suitable lens.

or

Explain why the planets do not twinkle?

22. What is biological magnification? Will the levels of this magnification be different at different Levels of the ecosystem?
23. Name the parts A, B, C and D of human brain.

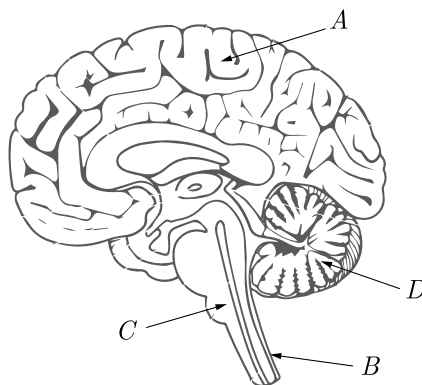

24. How is the amount of urine produced regulated?
25. Identify the reducing agent in the following reactions:
- (i) $\text{H}_2\text{O} + \text{F}_2 \longrightarrow \text{HF} + \text{HOF}$
(ii) $\text{Fe}_2\text{O}_3 + 3\text{CO} \longrightarrow 2\text{Fe} + 3\text{CO}_2$

or

Which among the following changes are exothermic or endothermic in nature?

- (i) Decomposition of ferrous sulphate.
(ii) Dilution of sulphuric acid.
(iii) Dissolution of sodium hydroxide in water.
(iv) Dissolution of ammonium chloride in water.

Continue on next page.....

Click the Following Button to See the Free MS/Solutions

SOLUTIONS

26. Write two different ways in which glucose is oxidised to provide energy in human body. Write the products formed in each case.

SECTION-C

Question no. 27 to 33 are short answer questions.

27. (i) Create a food chain of the following organisms: Insect, Hawk, Grass, Snake, Frog?
(ii) Name the organism at the third trophic level of the created food chain.
(iii) Which organism of this food chain will have the highest concentration of non-biodegradable chemicals?
(iv) Name the phenomenon associated with it.
(v) If 10,000 joules of energy is available to frogs, how much energy will be available to snakes in this food chain?
28. If the image formed by a lens for all positions of an object placed in front of it is always erect and diminished, what is the nature of this lens? Draw a ray diagram to justify your answer. If the numerical value of the power of this lens is 10 D, what is its focal length in the Cartesian system?
29. The following diagram shows two parallel straight conductors carrying same current. Copy the diagram and draw the pattern of the magnetic field lines around them showing their directions. What is the magnitude of magnetic field at a point 'X' which is equidistant from the conductors? Give justification for your answer.

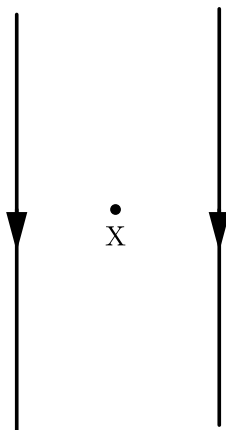

or

Give reasons for the following:

- (i) There is either a convergence or a divergence of magnetic field lines near the ends of a current carrying straight solenoid.
(ii) The current carrying solenoid when suspended freely rests along a particular direction.
(iii) The burnt out fuse should be replaced by another fuse of identical rating.

Continue on next page.....

Click the Following Button to See the Free MS/Solutions

SOLUTIONS

30. Identify the compound X on the basis of the reactions given below. Also, write the name and chemical formulae of A, B and C.

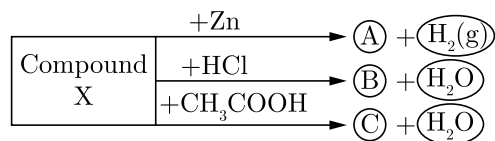

31. The image of an object formed by a mirror is real, inverted and is of magnification -1 . If the image is at the distance of 30 cm from the mirror, where is the object placed? Find the position of the image if the object is now moved 20 cm towards the mirror. What is the nature of the image obtained? Justify your answer with the help of ray diagram.
32. List in tabular form three distinguishing features between autotrophic nutrition and heterotrophic nutrition.
- or**
- Design an activity to show that CO_2 is produced during breathing. Name the intermediate and the end products of glucose breakdown in aerobic respiration.
33. What is meant by skeletal type chemical equation? What does it represents? Using the equation for electrolytic decomposition of water, differentiate between a skeletal chemical equation and a balanced chemical equation.

SECTION-D

Question no. 34 to 36 are Long answer questions.

34. (i) What are dominant and recessive traits?
 (ii) Is it possible that a trait is inherited but may not be expressed in the next generation? Give a suitable example to justify this statement.
- or**
- (i) Why did Mendel choose garden pea for his experiments? Write two reasons.
 (ii) What are mono-hybrid and dihybrid cross?
 (iii) How Mendel proved that tallness is the dominant trait and dwarfness is recessive in a pea plant? Explain with the help of a mono-hybrid cross.
35. PQ is a current carrying conductor in the plane of the paper as shown in the figure below.

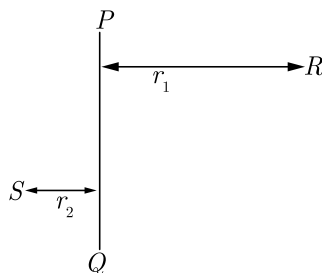

Continue on next page.....

Click the Following Button to See the Free MS/Solutions

SOLUTIONS

- (i) Find the directions of the magnetic fields produced by it at points R and S ? Given $r_1 > r_2$, where will the strength of the magnetic field be larger? Give reasons.
- (ii) Field strength at which point will be greater?
- (iii) If the polarity of the battery connected to the wire is reversed, how would the direction of the magnetic field be changed?
- (iv) Explain the rule that is used to find the direction of the magnetic field for a straight current carrying conductor.

36. You are given balls and stick model of six carbon atoms and fourteen hydrogen atoms and sufficient number of sticks. In how many ways one can join the models of six carbon atoms and fourteen hydrogen atoms to form different molecules of C_6H_{14} ?

or

Write the chemical formula and name of the compound which is the active ingredient of all alcoholic drinks. List its two uses. Write chemical equation and name of the product formed when this compound reacts with:

- (i) sodium metal
- (ii) hot concentrated sulphuric acid.

SECTION-E

Question no. 37 to 39 are case-based/data-based questions with 2 to 3 short sub-parts. Internal choice is provided in one of these sub-parts.

37. A compound microscope is an instrument which consists of two lenses L_1 and L_2 . The lens L_1 called objective, forms a real, inverted and magnified image of the given object. This serves as the object for the second lens L_2 , the eye piece. The eye piece functions like a simple microscope or magnifier. It produces the final, image, which is inverted with respect to the original object, enlarged and virtual.
- (i) What types of lenses must be L_1 and L_2 ?
 - (ii) If on applying Cartesian sign convention for spherical lenses, the image distance obtained is negative, state the significance of the negative sign.
 - (iii) If power of the eyepiece L_2 is 5 dioptres and it forms an image at a distance of 80 cm from its optical centre, at what distance should the object be?
- or
- (iv) What is the value and sign of magnification (according to the new cartesian sign convention) of the image formed by L_1 and L_2 ?

38. The growing size of the human population is a cause of concern for all people. The rate of birth and death in a given population will determine its size. Reproduction is the process by which organisms increase their population. The process of sexual maturation for reproduction is gradual and takes place while general body growth is still going on. Some degree of sexual maturation does not necessarily mean that the mind or body is ready for sexual acts or for having and bringing up children. Various contraceptive devices are being used by human beings to control the size of population.
- (i) What is contraception?
 - (ii) Which contraceptive method changes the hormonal balance of the body?
 - (iii) List two common signs of sexual maturation in boys and girls.
- or
- (iv) List any two reasons why the Government has banned prenatal sex determination by law?

Continue on next page.....

Click the Following Button to See the Free MS/Solutions

SOLUTIONS

39. Rishabh wanted to study displacement reactions. He knows that he needs a metal and a salt solution of a different metal. So, he takes two tubes T_1 and T_2 , out of which in T_1 , he placed a copper wire in iron sulphate solution and in T_2 , he placed an iron nail in copper sulphate solution as shown below:

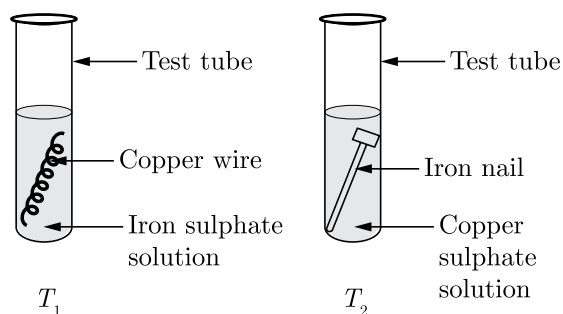

- (i) Based on the given information, which test tube will undergo displacement reaction? Also, write the chemical reaction occurring in that test tube.
- (ii) State the changes observed in T_1 and T_2 .
- or**
- (iii) What will happen (a) when zinc wire is used in place of copper wire in T_1 and (b) when silver nitrate is used in place of iron sulphate in T_1 ?

DOWNLOAD INDIA'S BEST STUDY MOBILE APP

- 30 Sample Paper with Solutions
- Chapterwise Question Bank of All Subject
- Previous 15 Years Solved Papers
- NCERT Solutions
- Case Study Questions with full Solutions
- **Word File of Material for Teachers**

Search by **NODIA** on Play Store to Download App

Add 89056 29969 in Your Class Whatsapp Group to Get Link



Click the Following Button to See the Free MS/Solutions

SOLUTIONS

Sample Paper 30

Class X 2023-24

Science (086)

Time: 3 Hours

Max. Marks: 80

General Instructions:

1. This question paper consists of 39 questions in 5 sections.
 2. All questions are compulsory. However, an internal choice is provided in some questions. A student is expected to attempt only one of these questions.
 3. Section A consists of 20 Objective Type questions carrying 1 mark each.
 4. Section B consists of 6 Very Short questions carrying 02 marks each. Answers to these questions should be in the range of 30 to 50 words.
 5. Section C consists of 7 Short Answer type questions carrying 03 marks each. Answers to these questions should be in the range of 50 to 80 words.
 6. Section D consists of 3 Long Answer type questions carrying 05 marks each. Answer to these questions should be in the range of 80 to 120 words.
 7. Section E consists of 3 source-based/case-based units of assessment of 04 marks each with sub-parts.
-

SECTION-A

Select and write one most appropriate option out of the four options given for each of the questions 1 – 20.

1. A light ray is incident perpendicularly to one face of a 90° prism and is totally internally reflected at the glass-air interface. If the angle of reflection is 45° , we conclude that the refractive index

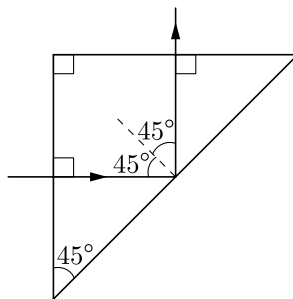

- (a) $n > \frac{1}{\sqrt{2}}$
 - (b) $n > \sqrt{2}$
 - (c) $n < \frac{1}{\sqrt{2}}$
 - (d) $n < \sqrt{2}$
2. When $\text{Ca}(\text{NO}_3)_2$ is heated, it gives CaO , $\text{NO}_2(\text{g})$ and $\text{O}_2(\text{g})$. The correct number of moles of $\text{Ca}(\text{NO}_3)_2$, CaO , $\text{NO}_2(\text{g})$ and $\text{O}_2(\text{g})$ are present in the reaction are respectively
 - (a) 1, 2, 4, 1
 - (b) 2, 2, 4, 1
 - (c) 2, 1, 3, 2
 - (d) 2, 2, 2, 1

Click the Following Button to See the Free MS/Solutions

SOLUTIONS

3. If a few drops of a concentrated acid accidentally spills over the hand of a student, what should be done?
- Wash the hand with saline solution.
 - Wash the hand immediately with plenty of water and apply a paste of sodium hydrogen carbonate.
 - After washing with plenty of water apply solution of sodium hydroxide on the hand.
 - Neutralize the acid with a strong alkali.
4. In humans, the life processes are controlled and regulated by
- reproductive and endocrine systems
 - respiratory and nervous systems
 - endocrine and digestive systems
 - nervous and endocrine systems
5. Which of the following oxide(s) of iron would be obtained on prolonged reaction of iron with steam?

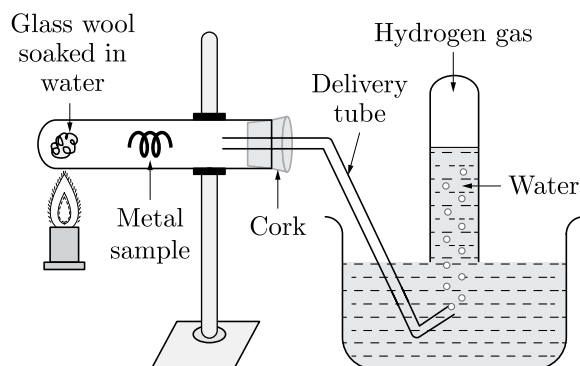

- FeO
 - Fe₂O₃
 - Fe₃O₄
 - Fe₂O₃ and Fe₃O₄
6. Which one of the following is the example of precipitation reaction according to the given diagram?

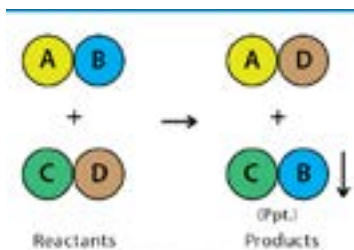

- $\text{Cu (s)} + 2\text{AgNO}_3(\text{aq}) \longrightarrow \text{Cu(NO}_3)_2(\text{aq}) + 2\text{Ag (s)}$
- $\text{CuCO}_3(\text{s}) \xrightarrow{\text{Heat}} \text{CuO (s)} + \text{CO}_2(\text{g})$
- $\text{N}_2(\text{g}) + 3\text{H}_2(\text{g}) \longrightarrow 2\text{H}_3(\text{g})$
- $\text{AgNO}_3(\text{aq}) + \text{NaCl (aq)} \longrightarrow \text{AgCl (s)} + \text{NaNO}_3(\text{aq})$

Continue on next page.....

Click the Following Button to See the Free MS/Solutions

SOLUTIONS

7. Which of the following are effects of atmospheric refraction?

1. Twinkling of stars.
2. Tyndall effect.
3. Advance sunrise and delayed sunset.

Choose the correct option from the codes given below:

- (a) 1 and 2
- (b) 2 and 3
- (c) 1 and 3
- (d) 1, 2 and 3

8. During the process of respiration in plants, the direction of diffusion of oxygen and carbon dioxide depends upon

- (a) the environmental conditions
- (b) the requirements of the plant
- (c) both (a) and (b)
- (d) none of these

9. If the central portion of a convex lens is wrapped in black paper as shown in the figure.

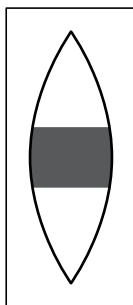

- (a) No image will be formed by the remaining portion of the lens
- (b) The full image will be formed but it will be less bright
- (c) The central portion of the image will be missing
- (d) There will be two images each produced by one of the exposed portions of the lens

10. A trait in an organism is shown in the figure influenced by



- (a) paternal DNA only
- (b) maternal DNA only
- (c) both maternal and paternal DNA
- (d) neither by paternal nor by maternal

Continue on next page.....

Click the Following Button to See the Free MS/Solutions

SOLUTIONS

11. Reproduction is essential for living organisms in order to
- keep the individual organism alive
 - fulfil their energy requirement
 - maintain growth
 - continue the species generation after generation
12. Which of the following statements about the reaction given below are incorrect?
- $$2\text{PbO}(s) + \text{C}(s) \longrightarrow 2\text{Pb}(s) + \text{CO}_2(g)$$
- Lead is getting reduced.
 - Carbon dioxide is getting oxidised.
 - Carbon is getting oxidised.
 - Lead oxide is getting reduced.
- 1 and 2
 - 3 and 4
 - 1 and 3
 - 2 and 4
13. Which of the following statements is correct about an aqueous solution of an acid and of base?
- Higher the pH, stronger the acid
 - Higher the pH, weaker the acid
 - Lower the pH, stronger the base
 - Lower the pH, weaker the base
- 1 and 3
 - 2 and 3
 - 1 and 4
 - 2 and 4
14. A full length of a distant tall building can definitely be seen by using



- a concave mirror
- a convex mirror
- a plane mirror
- both concave as well as plane mirror

Continue on next page.....

Click the Following Button to See the Free MS/Solutions

SOLUTIONS

15. $\text{AgNO}_3(\text{aq}) + \text{NaCl}(\text{aq}) \longrightarrow \text{AgCl}(\text{s}) + \text{NaNO}_3(\text{aq})$ Only two of the following statements accurately describe what happens in the mouth.
1. Amylase breaks down large starch molecules into smaller maltose molecules.
 2. Chewing increases the surface area of food for digestion.
 3. Saliva emulsifies fats into smaller droplets.
 4. Teeth breakup large insoluble molecules into smaller soluble molecules.
- Which statements are correct?
- (a) 1 and 2
 - (b) 2 and 3
 - (c) 3 and 4
 - (d) 1 and 4
16. Oils on treating with hydrogen in the presence of palladium or nickel catalyst form fats as shown in the figure.



This is an example of

- (a) Addition reaction
- (b) Substitution reaction
- (c) Displacement reaction
- (d) Oxidation reaction

Question no. 17 to 20 are Assertion - Reasoning based questions.

17. **Assertion :** A reducing agent is a substance which can either accept electron.
Reason : A substance which helps in oxidation is known as reducing agent.
- (a) Both Assertion and Reason are True and Reason is the correct explanation of the Assertion.
 - (b) Both Assertion and Reason are True but Reason is not the Correct explanation of the Assertion.
 - (c) Assertion is True but the Reason is False.
 - (d) Assertion (A) is false but reason (R) is true.
18. **Assertion :** Abscisic acid is responsible for wilting of leaves.
Reason : It is a growth inhibitor.
- (a) Both assertion (A) and reason (R) are true and reason (R) is the correct explanation of assertion (A).
 - (b) Both assertion (A) and reason (R) are true but reason (R) is not the correct explanation of assertion (A).
 - (c) Assertion (A) is true but reason (R) is false.
 - (d) Assertion (A) is false but reason (R) is true.

Continue on next page.....

Click the Following Button to See the Free MS/Solutions

SOLUTIONS

19. **Assertion :** Respiration is not a biochemical process opposite to photosynthesis.
Reason : Energy is released during respiration.
- (a) Both Assertion and Reason are true and Reason is the correct explanation of Assertion.
 - (b) Both Assertion and Reason are true but Reason is not the correct explanation of Assertion.
 - (c) Assertion is true but Reason is false.
 - (d) Assertion is false but Reason is true.
20. **Assertion :** The 200 W bulbs glow with more brightness than 100 W bulbs.
Reason : A 100 W bulb has more resistance than 200 W bulb.
- (a) Both assertion (A) and reason (R) are true and reason (R) is the correct explanation of assertion (A).
 - (b) Both assertion (A) and reason (R) are true but reason (R) is not the correct explanation of assertion (A).
 - (c) Assertion (A) is true but reason (R) is false.
 - (d) Assertion (A) is false but reason (R) is true.

SECTION-B

Question no. 21 to 26 are very short answer questions.

21. A calcium compound which is a yellowish white powder is used as a disinfectant and also in textile industry. Name the compound. Which gas is released when this compound is left exposed to air ?

or

Explain why an aqueous solution of sodium sulphate is neutral while an aqueous solution of sodium carbonate is basic in nature.

22. What do you mean by electroencephalograph ?
23. Why is variation beneficial for the species, but not necessary for the individual?
24. What is grafting? What do the terms 'stock' and 'scion' mean in grafting?
25. An object is placed at a distance of 15 cm from a convex lens of focal length 20 cm. List four observations (nature, position, etc.) of the image formed by the lens.

or

An object is placed at a distance of 12 cm in front of a concave mirror of radius of curvature 30 cm. List four characteristics of the image formed by the mirror.

26. What are the heterotrophs ?

Click the Following Button to See the Free MS/Solutions

SOLUTIONS

SECTION-C

Question no. 27 to 33 are short answer questions.

27. 1 g of copper powder was taken in a China dish and heated. What change takes place on heating ? When hydrogen gas is passed over this heated substance, a visible change is seen in it, Give the chemical equations of reactions, the name and the colour of the products formed in each case.

28. (a) Show the formation of Na_2O by the transfer of electrons between the combining atoms.
(b) Why are ionic compounds usually hard ?
(c) How is it that ionic compounds in the solid state do not conduct electricity and they do so when in molten state?

29. How are involuntary action and reflex action different from each other ?

or

A motor cycle rider without helmet just an accident and suffered a spinal cord injury. In this case which signals will get disrupted and why ?

30. A boy uses spectacles of focal length -60 cm . Name the defect of vision he is suffering from. Which lens is used for the correction of this defect ? Compute the power of this lens.

31. While sitting in the last row, a student has difficulty in reading the blackboard clearly. State the defect of vision the student is suffering from. Mention two causes of this defect. Suggest a suitable lens for the correction of this defect.

32. (a) Define the term volt.
(b) State the relation between work, charge and potential difference for an electric circuit.
Calculate the potential difference between the terminals of a battery if 100 joules of work is required to transfer 20 coulombs of charge from one terminal of the battery to the other.

or

(a) In a given ammeter, a student saw that needle indicates 12th division in ammeter while performing an experiment to verify Ohm's law. If ammeter has 10 divisions between 0 to 0.5 A, then what is the ammeter reading corresponding to 12th division ?

(b) How do you connect an ammeter and a voltmeter in an electric circuit ?

33. (i) Create a terrestrial food chain depicting four trophic levels.
(ii) Why do we not find food chains of more than four trophic levels in nature?

Continue on next page.....

Click the Following Button to See the Free MS/Solutions

SOLUTIONS

SECTION-D

Question no. 34 to 36 are Long answer questions.

34. In what forms are metal found in nature ? With the help of examples explain how metals react with oxygen, water and dilute acids. Also write chemical equations for the reaction.

or

Give reason for the following:

- (i) Gold and platinum are used in jewellery.
 - (ii) Copper cannot displace hydrogen from dilute acids.
 - (iii) Stainless steel does not rust easily.
 - (iv) Metals can be given different shapes according to our needs.
 - (v) Zinc does not give hydrogen gas on reacting with HNO_3 .
35. (i) How is lymph formed ?
(ii) Write two points of difference between blood and lymph.
(iii) State two important functions of lymph.

or

What is transpiration ? Mention its importance to the plants.

36. What are magnetic field lines? How is the direction of a magnetic field at a point determined ? Draw the magnetic field lines (including field directions) of the magnetic field due to a circular coil of current. Name any two factors on which the magnitude of the magnetic field due to this coil depends.

SECTION-E

Question no. 37 to 39 are case-based/data-based questions with 2 to 3 short sub-parts. Internal choice is provided in one of these sub-parts.

37. 'Salts' refer to the compound formed when an acid reacts with a base. These reactions are known as neutralisation reactions. These reactions are often used in the laboratories to calculate the exact concentration of an acid or an alkali when the other is known. The familiar example of salt is sodium chloride (NaCl), which we use in our food on daily basis and is known as rock salt.
It is prepared by the reaction of hydrochloric acid and sodium hydroxide solution. This salt is used to prepare various compounds. When electricity is pass through an aqueous solution of sodium chloride (called brine), it decomposes to form sodium hydroxide. The process is called the chlor-alkali process because of the products formed-chlor and alkali for sodium hydroxide.

Continue on next page.....

Click the Following Button to See the Free MS/Solutions

SOLUTIONS

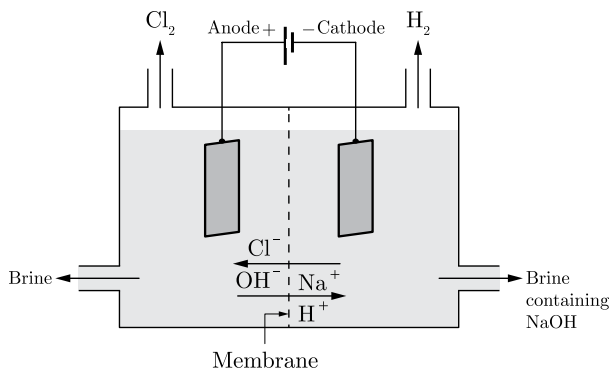

- (i) Write the chemical reaction of chlor-alkali process.
 - (ii) Name the gases formed at the anode and the cathode.
 - (iii) Write one use each of chlorine and hydrogen gas.
- or**
- (iv) How will you prepare baking soda from sodium chloride?

- 38.** The reproductive parts of angiosperms are located in the flower. The different parts of a flower are sepals, petals, stamens and carpels. Stamens and carpels are the reproductive parts of a flower which contain the germ-cells. The flower may be unisexual (papaya, watermelon) when it contains either stamens or carpels or bisexual (hibiscus, mustard) when it contains both stamens and carpels. Stamen is the male reproductive part and it produces pollen grains that are yellowish in colour. Carpel is present in the centre of a flower and is the female reproductive part. It is made of three parts. The swollen bottom part is the ovary, middle elongated part is the style and the terminal part which may be sticky is the stigma. The ovary contains ovules and each ovule has an egg cell. The male germ-cell produced by pollen grain fuses with the female gamete present in the ovule. This fusion of the germ-cells or fertilization gives us the zygote which is capable of growing into a new plant.

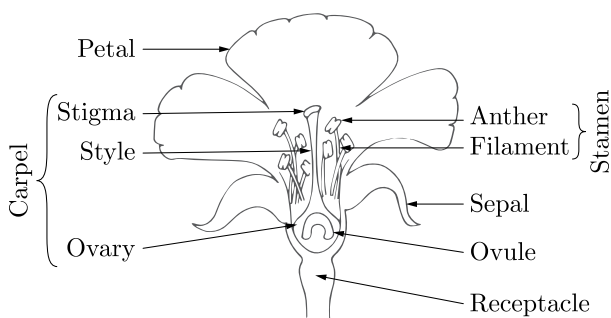

- (i) What are the different parts of a flower?
 - (ii) Name the reproductive parts of a flower.
 - (iii) Which is the male reproductive part of a flower?
- or**
- (iv) Which is the female reproductive part of a flower?

- 39.** The image formed by a convex lens depends on the position of the object in front of the lens. When the object is placed anywhere between focus and infinity, the image formed by convex lens is real and inverted. The image is not obtained on the screen why the object is placed between the focus and the lens. The distance between the optical centre O of the convex lens and the focus point F_1 and F_2 is its focal length. When the object shifts from $-\infty$ to F_1 , the image moves from F_2 to $+\infty$.

Continue on next page.....

Click the Following Button to See the Free MS/Solutions

SOLUTIONS

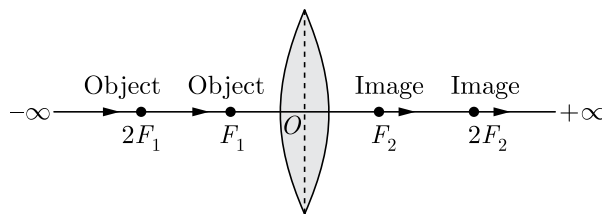

When the object shifts from F_1 to O , the image moves $-\infty$ to O .

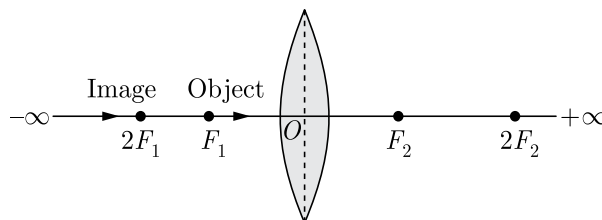

A student did an experiment with a convex lens. He put an object at different distances from the lens. In each case, he measured the distance of the image from the lens. The results were recorded in the following table.

Object distance (in cm)	Image distance (in cm)
25	100
30	24
40	60
60	30
120	40

Unfortunately, his results are written in the wrong order.

- (i) Rewrite the image distances in the correct order.
- (ii) What is the minimum distance between an object and its real image formed by a convex lens ?
- (iii) What is the focal length of this lens ?

or

- (iv) How do you determine if a lens is concave or convex?

□□□□□□

DOWNLOAD INDIA'S BEST STUDY MOBILE APP

- 30 Sample Paper with Solutions
- Chapterwise Question Bank of All Subject
- Previous 15 Years Solved Papers
- NCERT Solutions
- Case Study Questions with full Solutions
- **Word File of Material for Teachers**

Search by **NODIA** on Play Store to Download App

Add 89056 29969 in Your Class Whatsapp Group to Get Link

Click the Following Button to See the Free MS/Solutions

SOLUTIONS